

V1.0 2026-03-19

Residential Smart Off-Grid Inverter

EO G2 3.0-6.0kW

- LX A5.0-10
- LX A5.0-30

Solutions Manual

GOODWE

Copyright Statement

Copyright Statement

Copyright© GoodWe Technologies Co., Ltd. 2026. All rights reserved.

Without authorization from GoodWe Technologies Co., Ltd., no part of this manual may be reproduced, disseminated, or uploaded to public networks or third-party platforms in any form.

Trademark Authorization

GOODWE and other GOODWE trademarks used in this manual are owned by GoodWe Technologies Co., Ltd. All other trademarks or registered trademarks mentioned in this manual belong to their respective owners.

Notice

Due to product version upgrades or other reasons, the content of this document is updated periodically. Unless otherwise agreed, the content of this document cannot replace the safety precautions on the product label. All descriptions in this document are for guidance only.

About This Manual

Overview

This document primarily introduces the product information, installation and wiring, configuration and commissioning, troubleshooting, and maintenance for the energy storage system composed of inverters, battery systems, and smart meters. Please read this manual carefully before installing and using the product to understand the product safety information and familiarize yourself with the product's functions and features. The document may be updated periodically; please obtain the latest version of the materials and more product information from the official website.

Applicable Products

The energy storage system includes the following products:

Product Type	Product Information	Description
Inverter	GW3K-EO-G20	Rated Output Power: 3.0kW
	GW3.6K-EO-G20	Rated Output Power: 3.6kW
	GW5K-EO-G20	Rated Output Power: 5.0kW
	GW6K-EO-G20	Rated Output Power: 6.0kW
Battery System	LX A5.0-10	Rated Capacity: 5.0kWh, Maximum Support for 15 Clusters in Parallel
	LX A5.0-30	Rated Capacity: 5.12kWh, Maximum Support for 30 Clusters in Parallel
Smart Meter	GMK110	Monitoring module in the energy storage system, capable of detecting operating voltage, current, and other information in the system.

Symbol Definition



Indicates a highly hazardous situation which, if not avoided, will result in death or serious injury.

 WARNING

Indicates a potentially hazardous situation which, if not avoided, could result in death or serious injury.

 CAUTION

Indicates a potentially hazardous situation which, if not avoided, may result in minor or moderate injury.

NOTE

Emphasizes or supplements the content, and may provide tips or tricks for optimal product use, helping you solve a problem or save time.

Table of Contents

1 Safety Precautions	12
1.1 General Safety	12
1.2 personnel requirements	13
1.3 System Safety	14
1.3.1 PV String Safety	16
1.3.2 Inverter Safety	17
1.3.3 Battery Safety	18
1.3.4 Smart Meter Safety	20
1.4 Safety Symbols and Certification Marks	21
2 System Introduction	24
2.1 System Overview	24
2.2 Product Overview	28
2.2.1 Inverter	28
2.2.2 Battery	30
2.2.2.1 LX A5.0-10	30
2.2.2.2 LX A5.0-30	31
2.2.3 Smart Meter	32
2.3 Supported Grid Types	33
2.4 System Working Mode	33
3 Check and Storage	40
3.1 Check Before Receiving	40

3.2 deliverables	40
3.2.1 Inverter Deliverables	40
3.2.2 Batteries Deliverables	41
3.2.2.1 Battery Deliverables (LX A5.0-30)	41
3.2.2.2 Battery Deliverables (LX A5.0-10)	43
3.2.3 Smart Meter Deliverables	44
3.2.3.1 Smart Meter (GMK110)	44
3.3 Storage	45
4 Installation	48
4.1 System Installation and Commissioning Procedure	48
4.2 Installation Requirements	48
4.2.1 Installation Environment Requirements	48
4.2.2 Installation Space Requirements	50
4.2.3 Tool Requirements	51
4.3 Equipment Handling	53
4.4 Installing the Inverter	53
4.5 Installing the Battery System	54
4.5.1 LX A5.0-30	55
4.5.2 LX A5.0-10	58
4.6 Installing the Smart Meter	60
5 System Wirings	62
5.1 System Wiring Electrical Block Diagram	62

5.2 Detailed System Wiring Diagram.....	64
5.2.1 Detailed System Wiring Diagram for Single Inverter.....	64
5.3 Preparing Materials.....	67
5.3.1 Preparing Breakers.....	68
5.3.2 Preparing Cables.....	69
5.4 dismantle Lower Cover of Enclosure Inverter.....	71
5.5 Connecting the PE cable.....	72
5.6 Connecting the PV Cable.....	73
5.7 Connecting the Battery Cable.....	74
5.7.1 Connecting the Power Cable between the Inverter and Battery.....	79
5.7.2 Connecting the Communication Cable between the Inverter and Battery.....	81
5.8 Connecting the AC Cable.....	83
5.9 Connecting the Meter Cable.....	85
5.10 Connecting the Inverter Communication Cable.....	86
5.11 Lower cover of Installing the Inverter enclosure.....	89
5.12 Cover.....	90
5.12.1 LX A5.0-10.....	90
5.12.2 LX A5.0-30.....	90
6 System Commissioning.....	91
6.1 Check Before Power ON.....	91
6.2 Power ON.....	91

6.3 Indicators	93
6.3.1 Battery Indicators	93
6.3.1.1 LX A5.0-10	93
6.3.1.2 LX A5.0-30indicator	95
6.3.2 Smart Meter Indicator	96
7 System Commissioning	97
7.1 Commissioning Method Overview	97
7.2 Configuration via LCD	97
7.2.1 LCD Overview	97
7.2.2 Quick Settings	99
7.2.3 Setting Advanced Parameters	105
7.2.4 Setting Immediate Charging	106
7.2.5 Setting the Basic Information	107
7.2.6 Setting Port Connection	109
7.2.7 Set communication	113
7.2.8 Viewing Device Information	114
8 Power Plant Monitoring	116
8.1 App Introduction	116
8.1.1 Matching products	116
8.1.2 Download the Installation SEMS+ App	116
8.1.3 Connection method	117
8.1.4 Common Icon Descriptions	117

8.1.5 Register an account	118
8.1.6 Login account	119
8.2 Remote monitoring	120
8.2.1 power station	120
8.2.1.1 Power Plant Creation	120
8.2.1.1.1 Fill in the power station information	120
8.2.1.1.2 New equipment	121
8.2.1.1.3 Quick Configuration	124
8.2.1.2 Viewing Power Plant Information	125
8.2.1.2.1 power station list	125
8.2.1.2.2 power station Details	126
8.2.1.2.3 Alarm (Installation Vendor)	129
8.2.1.3 Viewing Power Plant Information(Owner)	130
8.2.1.3.1 power station list	130
8.2.1.3.2 power station Details	131
8.2.1.4 Modify power station basic information	134
8.2.1.5 Configure Tariff information	135
8.2.1.6 Power Plant Management sharing	136
8.2.2 equipment	137
8.2.2.1 Equipment List	137
8.2.2.2 Equipment Details	138
8.2.2.3 Remote Control equipment	140

8.2.2.3.1 Set Inverter parameters	140
8.2.2.3.2 Set Battery parameters	143
8.2.2.3.3 Set meter parameters	143
8.2.2.3.4 Set the parameters of the home energy management device	144
8.3 Local Commissioning equipment	145
8.3.1 Proximal connection device	145
8.3.2 Local Access Interface Overview	147
8.3.3 Set device parameters	149
8.3.3.1 One-Click Configuration	150
8.3.3.2 Set Inverter parameters	151
8.3.3.3 Set Smart dongle parameters	155
8.3.3.4 Set Battery parameters	156
8.3.3.5 Set meter parameters	157
8.4 Service	159
8.4.1 Enable DNSP function	161
8.4.2 Using AI assistant	163
8.5 Account	164
8.5.1 Modify user information	164
8.5.2 Set App notification messages	165
8.5.3 Set up account security information	166
8.5.4 Set monitoring permissions	167
8.6 Troubleshooting	168

8.7 Appendix	169
8.7.1 National Safety Regulations	169
8.7.2 System operating mode	175
8.7.3 Inverter Parameters	178
8.7.3.1 Customized Safety Parameters	185
8.7.3.2 On-grid Power Dispatch parameters	198
8.7.3.3 Grid Remote Dispatch parameters	202
8.7.3.4 Reuse port parameters	202
8.7.4 Battery Technical Data	206
8.7.5 Smart Meter Technical Data	210
8.7.6 Smart dongle parameter	210
8.7.7 Household Energy Management Device Parameters	212
8.7.8 Operation and Maintenance Parameters	218
9 Maintenance	220
9.1 Power OFF the System	220
9.2 Removing the Equipment	221
9.3 Disposing of the Equipment	222
9.4 Routine Maintenance	222
9.5 fault	224
9.5.1 Viewing Fault/Alarms Information	224
9.5.2 Fault Information and Troubleshooting	224
9.5.2.1 System fault	225

9.5.2.2 Inverterfault	226
9.5.2.2.1 Troubleshooting (fault code F01-F40)	226
9.5.2.2.2 Troubleshooting (fault code F41-F80)	244
9.5.2.2.3 Troubleshooting (fault code F81-F121)	253
9.5.2.2.4 Troubleshooting(fault code F122-F163)	265
9.5.2.2.5 fault phenomenon handling	273
9.5.2.3 Batteryfault(LX A5.0-10)	291
9.5.2.4 Batteryfault(LX A5.0-30)	293
10 technical parameter	298
10.1 Inverter Parameters	298
10.2 Battery Technical Data	306
10.2.1 LX A5.0-10	306
10.2.2 LX A5.0-30	308
10.3 Smart Meter Technical Data	310
10.3.1 GMK110	310
11 Appendix	312
11.1 FAQ	312
11.1.1 How to conduct auxiliary detection for smart meters/CT?	312
11.1.2 How to Upgrade the Device Version	312
11.2 Explanation of Terms	313
11.3 Battery SN code meaning	314
12 Contact Information	316

1 Safety Precautions

The safety precautions contained in this document must always be followed when operating the device.

Warning

The equipment has been strictly designed and tested in compliance with safety regulations. However, as an electrical device, relevant safety instructions must be followed before performing any operations. Improper handling may result in serious injury or property damage.

1.1 General Security

Notice

- Due to product version upgrades or other reasons, the document content is updated periodically. Unless otherwise agreed, the document content cannot replace the safety precautions on the product labels. All descriptions in the document are for guidance only.
- Please read this document carefully before installing the device to understand the product and its precautions.
- All operations on the device must be performed by professional and qualified electrical technicians who are familiar with the relevant standards and safety regulations in the project location.
- When operating the device, use insulated tools and wear personal protective equipment to ensure personal safety. Contact with electronic components requires wearing anti-static gloves, anti-static wrist straps, anti-static clothing, etc., to protect the device from electrostatic damage.
- Unauthorized disassembly or modification may cause device damage, which is not covered under warranty.
- Device damage or personal injury caused by failure to install, use, or configure the device in accordance with the requirements of this document or the corresponding user manual is not within the responsibility of the device manufacturer. For more product warranty information, please visit the official website: <https://www.goodwe.com/warrantyrelated.html>.

1.2 Personnel Requirements

Attention

To ensure safety, compliance, and efficiency throughout the entire process of equipment transportation, installation, wiring, operation, and maintenance, all tasks must be performed by qualified personnel or professionals.

1. Qualified personnel or professionals include:
 - Personnel who have mastered knowledge of equipment working principles, system structure, risks, and hazards, and have received professional operation training or possess extensive practical experience.
 - Personnel who have received relevant technical and safety training, possess certain operational experience, are aware of potential dangers specific tasks may pose to themselves, and can take protective measures to minimize risks to themselves and others.
 - Qualified electrical technicians who meet the regulatory requirements of the country/region where they are located.
 - Personnel holding a degree in electrical engineering/an advanced diploma in electrical disciplines or equivalent/professional qualifications in the electrical field, and possessing at least 2/3/4 years of experience in testing and regulatory work using electrical equipment safety standards.
2. Personnel involved in special tasks such as electrical work, work at heights, and operation of special equipment must hold valid qualification certificates required by the location of the equipment.
3. Medium-voltage equipment operation must be performed by certified high-voltage electricians.
4. Equipment and component replacement is only permitted to be performed by authorized personnel.

1.3 System Security



- Before making any electrical connections, disconnect all upstream switches to ensure the device is powered off. Live operation is strictly prohibited, as it may lead to hazards such as electric shock.
- To prevent personal injury or equipment damage from live operations, a circuit breaker must be installed on the voltage input side of the equipment.
- During all operations including transportation, storage, installation, operation, usage, and maintenance, comply with applicable laws, regulations, standards, and specifications.
- The specifications of cables and components used for electrical connections must comply with local laws, regulations, standards, and specifications.
- Please use the cable connectors provided with the device to connect the cables. Damage caused by using other models of connectors is not within the manufacturer's responsibility.
- Ensure all cable connections on the device are correct, secure, and not loose. Improper wiring may cause poor contact or damage the equipment.
- The equipment's protective grounding wire must be securely connected.
- To protect the equipment and its components from damage during transportation, ensure transport personnel are professionally trained. Record the operational steps during transport and keep the equipment balanced to prevent it from falling.
- The equipment is heavy. Please assign personnel according to the equipment's weight to avoid exceeding the human lifting capacity, which could cause injury from dropping.
- Ensure the equipment is placed stably and not tilted. Equipment tipping over may cause equipment damage and personal injury.



- Avoid placing weight on the wiring terminals during equipment installation, as this may cause terminal damage.
- If the cable is subjected to excessive tension, it may lead to poor connections. When wiring, leave a certain length of slack in the cable before connecting it to the equipment's terminal ports.
- Cables of the same type should be bundled together. Different types of cables should be routed at least 30mm apart and must not be intertwined or cross-routed.
- Using cables in high-temperature environments may cause insulation aging and damage. Maintain a distance of at least 30mm between cables and heat-generating components or the periphery of heat source areas.

1.3.1 Photovoltaic String Safety

Warning

- Ensure the component frame and mounting system are properly grounded.
- After connecting the DC cables, ensure the cable connections are tight and secure, with no looseness. Improper wiring may lead to poor contact or high impedance, and could damage the inverter.
- Use a multimeter to measure the positive and negative poles of the DC cables to ensure correct polarity and no reverse connection; also ensure the voltage is within the allowable range.
- Use a multimeter to measure the DC cables to ensure correct polarity and no reverse connection; the voltage should be lower than the maximum DC input voltage. Damage caused by reverse connection and overvoltage is not covered under the equipment manufacturer's warranty.
- The PV string output does not support grounding. Before connecting the PV string to the inverter, ensure the minimum insulation resistance to ground of the PV string meets the minimum insulation resistance requirement ($R = \text{Maximum Input Voltage (V)} / 30\text{mA}$).
- Do not connect the same PV string to multiple inverters, as this may cause inverter damage.
- The PV modules used with the inverter must comply with IEC 61730 Class A standards.
- When the PV string input voltage or input current is high, it may cause the inverter output power to derate.

1.3.2 Inverter Safety

Warning

- Ensure the voltage and frequency at the grid connection point comply with the inverter's grid-connection specifications.
- It is recommended to install protective devices such as circuit breakers or fuses on the AC side of the inverter. The rating of the protective device must be greater than 1.25 times the inverter's maximum AC output current.
- If the inverter triggers an arc fault alarm fewer than 5 times within 24 hours, the alarm can be cleared automatically. After the 5th arc fault alarm, the inverter will shut down for protection. The fault must be cleared before the inverter can resume normal operation.
- If the photovoltaic system is not configured with a battery, using the BACK-UP function is not recommended, as it may cause a system power outage risk.
- Changes in grid voltage and frequency may cause the inverter's output power to derate.

1.3.3 Battery Safety

Danger

- Before operating any equipment within the system, ensure the equipment is powered off to avoid the risk of electric shock. Strictly adhere to all safety precautions in this manual and the safety labels on the equipment during operation.
- Do not disassemble, modify, or repair the battery or control box without official authorization from the equipment manufacturer. Otherwise, there is a risk of electric shock or equipment damage. Losses resulting from such actions are not covered by the manufacturer's liability.
- Do not impact, pull, drag, squeeze, or step on the equipment. Do not place the battery in fire, as there is a risk of explosion.
- Do not place the battery in high-temperature environments. Ensure there are no heat sources near the battery and that it is not exposed to direct sunlight. A fire may occur if the ambient temperature exceeds 60°C.
- Do not use the battery or control box if there are obvious defects, cracks, damage, or other abnormalities. Battery damage may lead to electrolyte leakage.
- Do not move the battery system while it is operating. If battery replacement or addition is required, please contact the after-sales service center.
- Battery short circuits may cause personal injury. The instantaneous high current from a short circuit can release a large amount of energy, potentially causing a fire.
- The battery DC circuit breaker must comply with the requirements of the AS/NZS 5139 standard.

Warning

- Battery current may be affected by factors such as temperature, humidity, weather conditions, etc., which may lead to battery current limiting and affect load capacity.
- If the battery fails to start, please contact the after-sales service center as soon as possible. Otherwise, the battery may be permanently damaged.
- Please perform regular inspection and maintenance on the battery according to its maintenance requirements.

- **Battery Electrolyte Leakage**

If the battery module leaks electrolyte, avoid contact with the leaked liquid or gas. Electrolyte is corrosive, and contact may cause skin irritation and chemical burns. If you accidentally come into contact with the leaked substance, perform the following actions:

- Inhalation: Evacuate from the contaminated area and seek medical help immediately.
- Eye contact: Rinse with clean water for at least 15 minutes and seek medical help immediately.
- Skin contact: Thoroughly wash the affected area with soap and water and seek medical help immediately.
- Ingestion: Induce vomiting and seek medical assistance immediately.

- **Fire**

- When the battery temperature exceeds 150°C, there is a risk of fire, and the battery may release toxic and harmful gases after catching fire.
- To prevent fires, ensure that carbon dioxide, Novec1230, or FM-200 fire extinguishers are available near the equipment.
- When extinguishing fires, do not use ABC dry powder fire extinguishers. Firefighters must wear protective clothing and self-contained breathing apparatus.

- **Battery Fire Suppression Function Triggered**

For batteries equipped with optional fire suppression functions, after the fire suppression function is triggered, perform the following actions:

- Immediately cut off the main power switch to ensure no current flows through the battery system.
- Conduct a preliminary visual inspection of the battery for any damage, deformation, leakage, or unusual odors. Check the battery casing, connectors, and cables.
- Use temperature sensors to detect the battery and its ambient temperature to ensure there is no risk of overheating.
- Isolate and mark the damaged battery, and dispose of it properly according to local regulations.

1.3.4 Electricity Meter Safety

Warning





If the grid voltage fluctuation exceeds 265V, long-term overvoltage operation may cause damage to the meter. It is recommended to add a 0.5A rated fuse on the voltage input side of the meter to protect it.









1.4 Safety Symbols and Certification Marks



Description

Danger

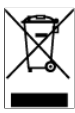
- After equipment installation, labels and warning signs on the enclosure must remain clearly visible. Do not cover, alter, or damage them.
- The enclosure warning label descriptions below are for reference only. Please refer to the actual labels on the equipment.

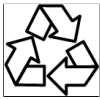
No.	Symbol	Meaning
1		Potential hazards exist during equipment operation. Take protective measures when operating the equipment.
2		High voltage danger. High voltage is present during equipment operation. When performing operations on the equipment, ensure the equipment is powered off.
3		The inverter surface is at high temperature. Do not touch during operation, as it may cause burns.
4		Use the equipment properly. There is a risk of explosion under extreme conditions.
5		The battery contains flammable materials. Beware of fire.

No.	Symbol	Meaning
6		The equipment contains corrosive electrolyte. Avoid contact with leaked electrolyte or vapor.
7		Delayed discharge. After powering off the equipment, wait for 5 minutes until it is fully discharged.
8		The equipment should be kept away from open flames or ignition sources.
9		The equipment should be kept out of reach of children.
10		Do not extinguish with water.
11		Before operating the equipment, read the product manual carefully.
12		Wear personal protective equipment during installation, operation, and maintenance.
13		The equipment must not be disposed of as household waste. Dispose of the equipment according to local laws and regulations, or return it to the equipment manufacturer.
14		Protective earth terminal.
15		Recycling symbol.

No.	Symbol	Meaning
16		CE marking.
17		TUV mark.
18		RCM mark.

2 System Introduction

2.1 System Overview

The residential smart inverter solution integrates devices such as the inverter, battery, smart meter, and smart communication stick. Within the photovoltaic system, it converts solar energy into electricity to meet household power demands. The system's energy IoT devices manage power-consuming equipment by identifying the overall power situation in the system, thereby intelligently managing electricity for use by loads, storage in the battery, or export to the grid.

 **Warning**

- Select the battery model according to the inverter and battery compatibility list. For requirements regarding batteries used in the same system, such as whether models can be mixed or if capacities must be consistent, please refer to the user manual of the corresponding battery model or contact the battery manufacturer for relevant specifications. Inverter and battery compatibility list: https://en.goodwe.com/Ftp/EN/Downloads/User%20Manual/GW_Battery%20Compatibility%20Overview-EN.pdf.
- Due to product version upgrades or other reasons, document content is updated periodically. For the compatibility between inverters and IoT products, please refer to: https://en.goodwe.com/Ftp/EN/Downloads/User%20Manual/GW_Compatibility-list-of-GoodWe-inverters-and-IoT-products-EN.pdf.
- For detailed networking and wiring diagrams for various scenarios, please refer to: [5.2.System Wiring Details\(Page 64\)](#).
- The energy storage system is not suitable for connecting devices that rely on a stable power supply, such as life-supporting medical equipment. Please ensure that a system power failure does not cause personal injury.
- In a system where the inverter operates completely off-grid, if the battery is exposed to prolonged low sunlight or rainy weather and cannot be replenished in time, it may lead to over-discharge, causing battery performance degradation or damage. To ensure long-term stable system operation, avoid completely draining the battery. Recommended measures are as follows:
 1. When operating off-grid, set a minimum SOC protection threshold. It is recommended to set the off-grid battery SOC lower limit to 30%.
 2. When the SOC approaches the protection threshold, the system will automatically enter load-limiting or protection mode.
 3. If there are multiple consecutive days of insufficient sunlight and the battery SOC is too low, promptly replenish the battery using an external energy source (such as a generator or grid-assisted charging).
 4. Regularly check the battery status to ensure it operates within a safe range.
 5. It is recommended to perform a full charge and discharge cycle on the battery every six months to calibrate the SOC accuracy.

Off-grid Load Capacity Specifications

Inverter Model	GW3K-EO-G20 GW3.6K-EO-G20	GW5K-EO-G20 GW6K-EO-G20
Single Motor Load Rated Power (kVA)	0.8	1.5
Total Motor Load Rated Power (kVA)	0.75*Pn	0.75*Pn
Capacitive Load (kVA)	0.33*Pn	0.33*Pn
Half-wave Load	0.5*Pn	0.5*Pn

Note: Pn: Inverter Rated Output Power.

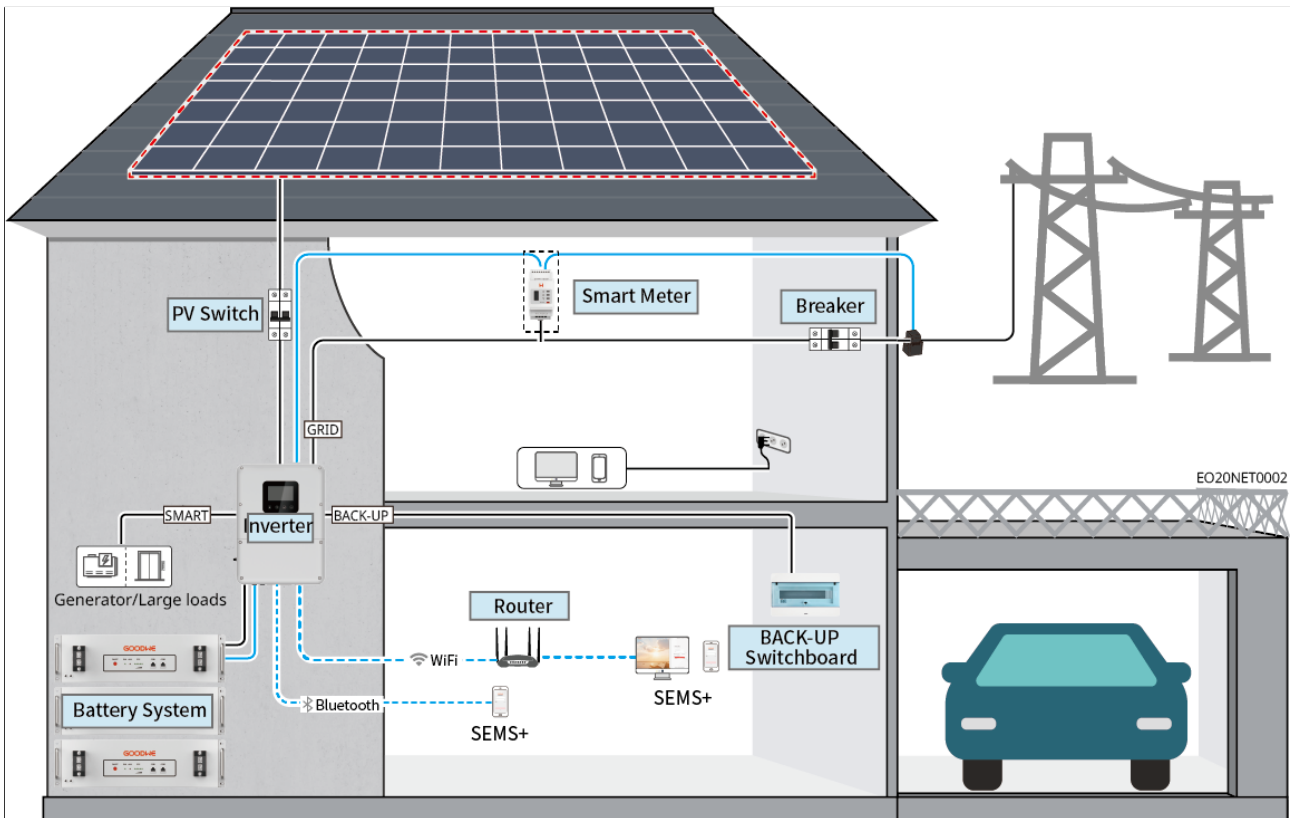

Device Type	Model	Description
Inverter	GW3K-EO-G20 GW3.6K-EO-G20 GW5K-EO-G20 GW6K-EO-G20	Supports connection to a generator or large load

Device Type	Model	Description
Battery System	LX A5.0-10	<ul style="list-style-type: none"> • Battery systems of different models cannot be mixed and used together. • Cluster expansion between different models is currently not supported. For the same model, cluster expansion is allowed within one year of customer purchase and use; it is not allowed after one year. • LX A5.0-10: Supports a maximum of 15 units in a cluster within the same system. • LX A5.0-30: Supports a maximum of 30 units in a cluster within the same system.
	LX A5.0-30	
	Lead-acid Battery	<ul style="list-style-type: none"> • Supports connection to AGM, GEL, and Flooded type lead-acid batteries. • Calculate the number of batteries that can be connected in series based on the lead-acid battery voltage. The total series voltage must not exceed 60V.
Smart Meter	Built-in Meter (Standard)	CT can be purchased from a distributor or independently. CT ratio requirement: 120A:40mA
	GMK110 (Purchase from distributor)	<ul style="list-style-type: none"> • When the length of the inverter's built-in CT cable is insufficient to connect to the distribution panel, it can be extended by connecting an external GMK110 meter. • GMK110: CT cannot be replaced. CT ratio: 120A/40mA
Large Load		<p>Supports SG Ready. Large load specifications:</p> <ol style="list-style-type: none"> 1. Total large load power < SMART port maximum output power 2. Large load power + BACK-UP power < AC maximum input power (Grid)

Device Type	Model	Description
Generator		Generator rated voltage must meet the inverter SMART port rated voltage.

2.2 Product Introduction

2.2.1 Inverter

Off-grid inverters in photovoltaic systems control and optimize energy flow through an integrated energy management system. They can supply the electricity generated in the photovoltaic system to loads or store it in batteries, etc.

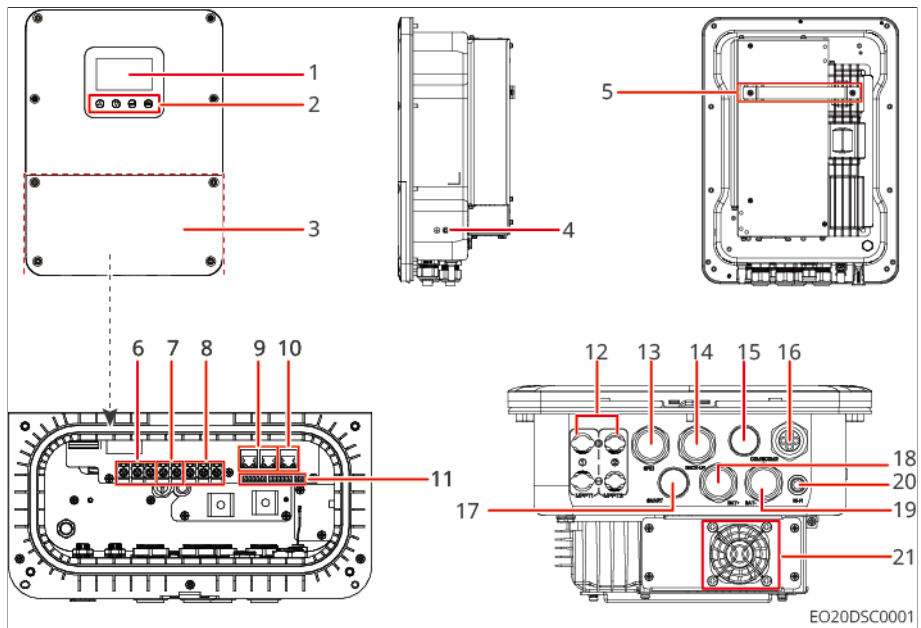

Serial Number	Model	Rated Output Power	Rated Output Voltage
1	GW3K-EO-G20	3kW	220/230
3	GW3.6K-EO-G20	3.6kW	220/230
4	GW5K-EO-G20	5kW	220/230

Serial Number	Model	Rated Output Power	Rated Output Voltage
5	GW6K-EO-G20	6kW	220/230

No.	Part/Silk Screen	Description
1	Display Screen	View inverter-related data
2	Buttons	Used in conjunction with the display screen to perform settings operations on the inverter
3	Inverter Case Lower Cover	-
4	Grounding Terminal/PE	Connect the protective earth wire
5	Mounting Bracket	For mounting the inverter
6	Grid Port/GRID	Connect AC cables to link the inverter to the grid
7	SMART Port	Used to connect a generator or large load
8	BACK-UP Port	Connect AC cables to link critical loads to the inverter
9	(Reserved) Parallel Communication Port	-
10	Battery Communication Port	Connect the battery communication cable
11	Communication Port	Can connect communication cables for load control, CT, RS485, remote shutdown/rapid shutdown, etc.
12	PV Cable Connection Port	Can connect DC input cables from PV modules. GW3K-EO-G20, GW3.6K-EO-G20: x 1 GW5K-EO-G20, GW6K-EO-G20: x 2
13	GRID	Grid cable outlet
14	BACK-UP	BACK-UP load cable outlet

No.	Part/Silk Screen	Description
15	COM1	Communication cable outlet
16	COM2	Parallel communication cable and battery communication cable outlet
17	SMART	Generator or large load cable outlet
18	BAT+	Battery positive power cable outlet
19	BAT-	Battery negative power cable outlet
20	Antenna	Enhances inverter communication signal
21	Fan	Used for inverter heat dissipation

Dimensions Introduction

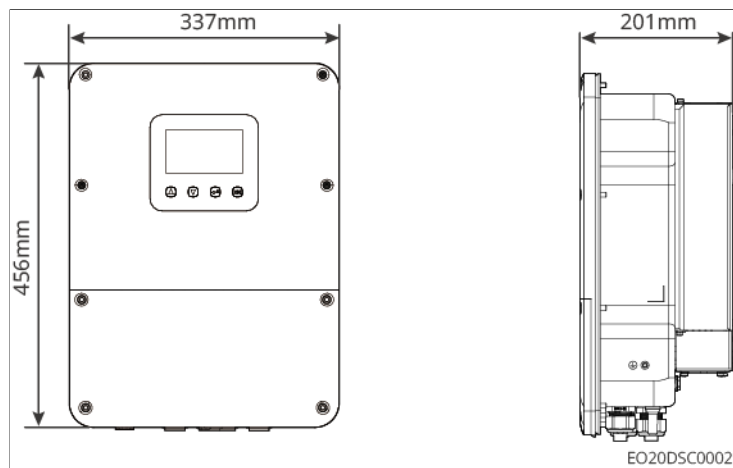

2.2.2 Battery

The battery system can store and release electrical energy according to the requirements of the photovoltaic energy storage system. Both the input and output ports of this energy storage system are high-voltage direct current. The inverter supports the use of lead-acid batteries. Please obtain relevant product information for lead-acid batteries from the lead-acid battery manufacturer.

2.2.2.1 LX A5.0-10

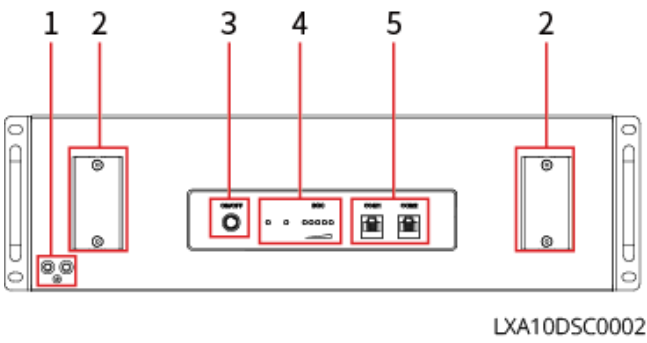
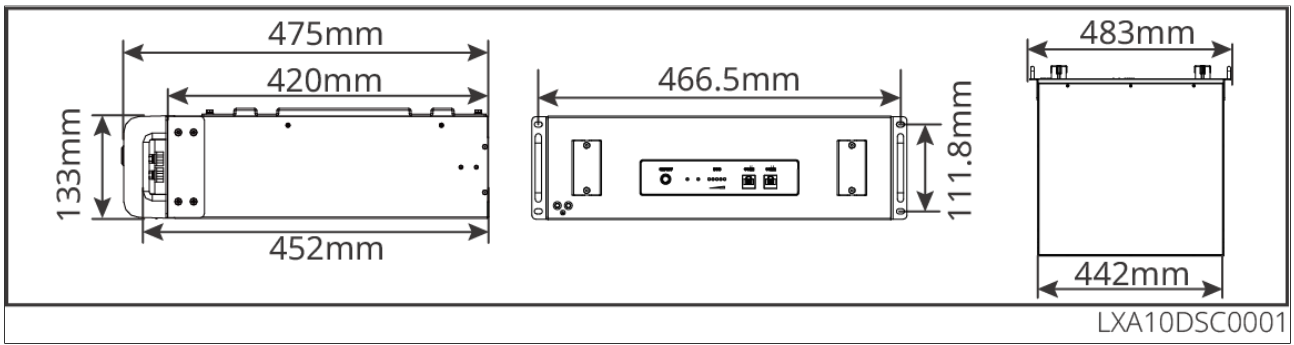

No.	Component/Silk Screen	Description
1	Protective Earth Terminal	Connect the chassis protective earth wire.
2	Battery DC Port	Connect the battery DC input cable.
3	Battery System Button	Used for battery power on/off and black start.
4	Indicator Light	Indicates the battery's operating status.
5	Communication Port	Connect the battery communication cable.

2.2.2.2 LX A5.0-30

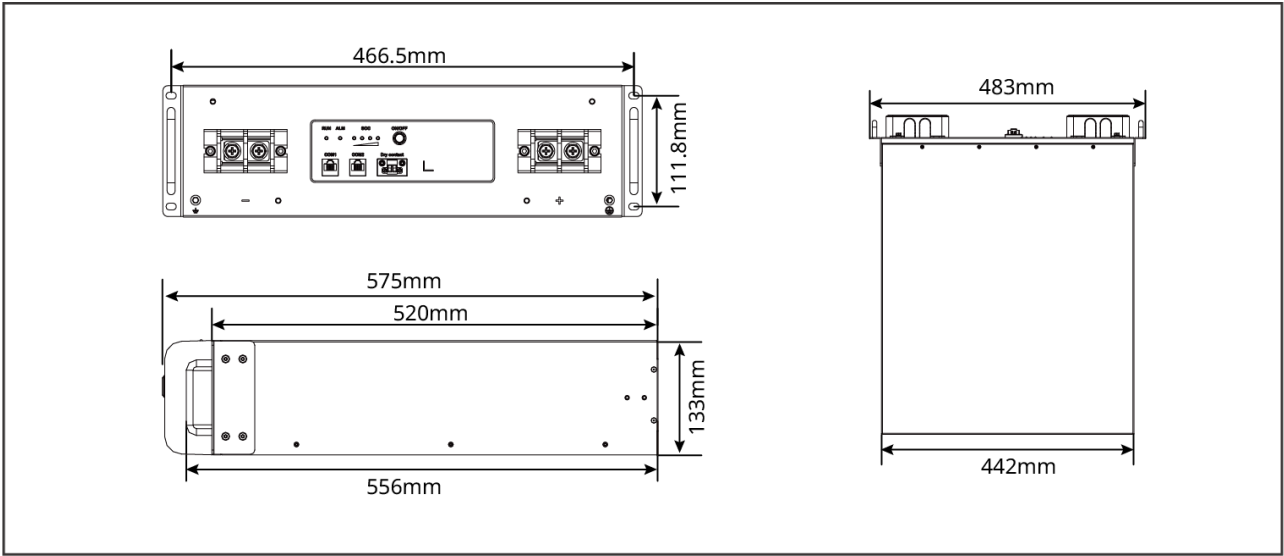

LXA30DSC0001

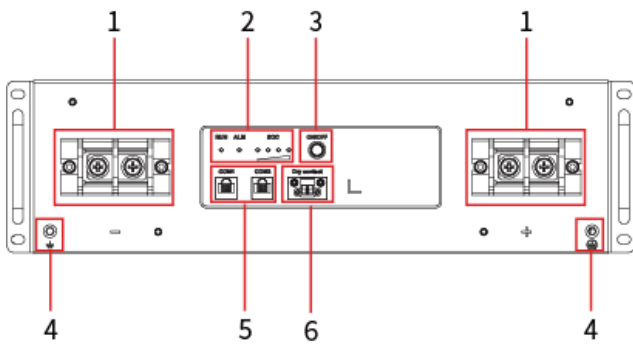

LXA30DSC0002

No.	Component/Silk screen	Description
1	Battery DC Port	Connect the battery DC input cable.
2	Indicator Light	Indicates the operating status of the battery.
3	Battery System Button	Used for battery power on/off and black start.
4	Protective Grounding Terminal	Connect the chassis protective ground wire.
5	Communication Port	Connect the battery communication cable.
6	Dry Contact	Reserved.

2.2.3 Smart Meter

A smart meter measures and monitors electrical data in a photovoltaic energy storage system, such as: voltage, current, frequency, power factor, power, etc.

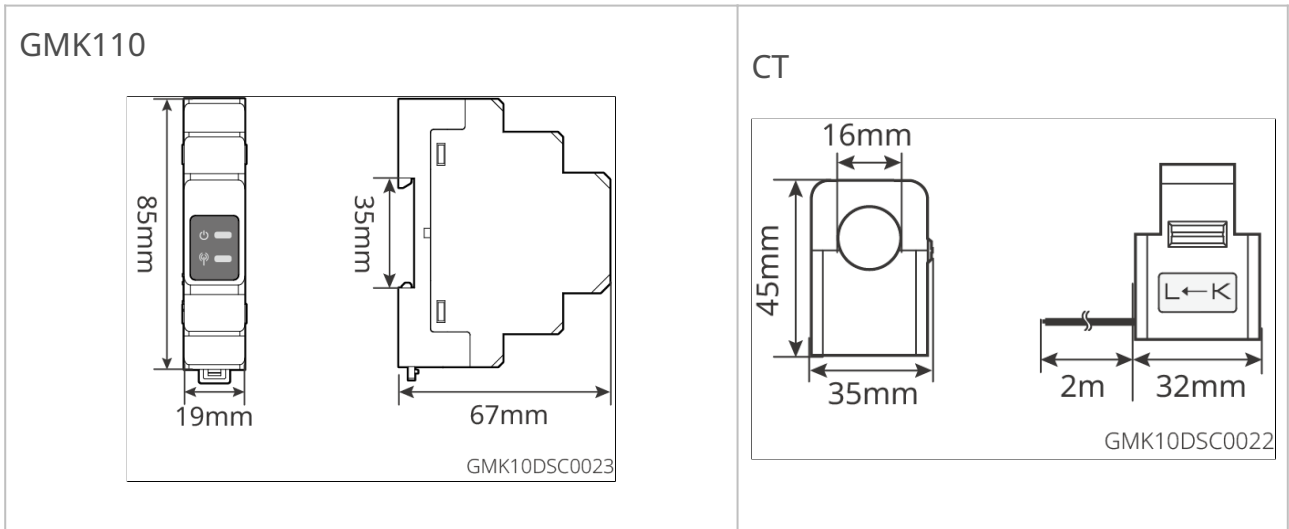

2.3 Supported Grid Types

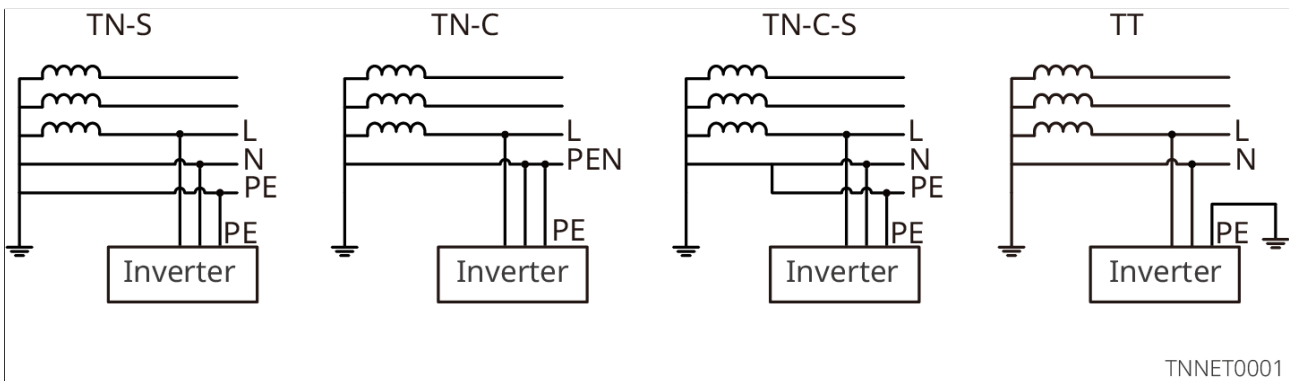

2.4 System Mode

Self-Consumption

- The fundamental operating mode of the system.
- PV-generated power is prioritized for supplying the load, with excess power used to charge the battery. When PV generation cannot meet the load demand, the

battery supplies power to the load. If the battery power is also insufficient to meet the load demand, the grid supplies power to the load.

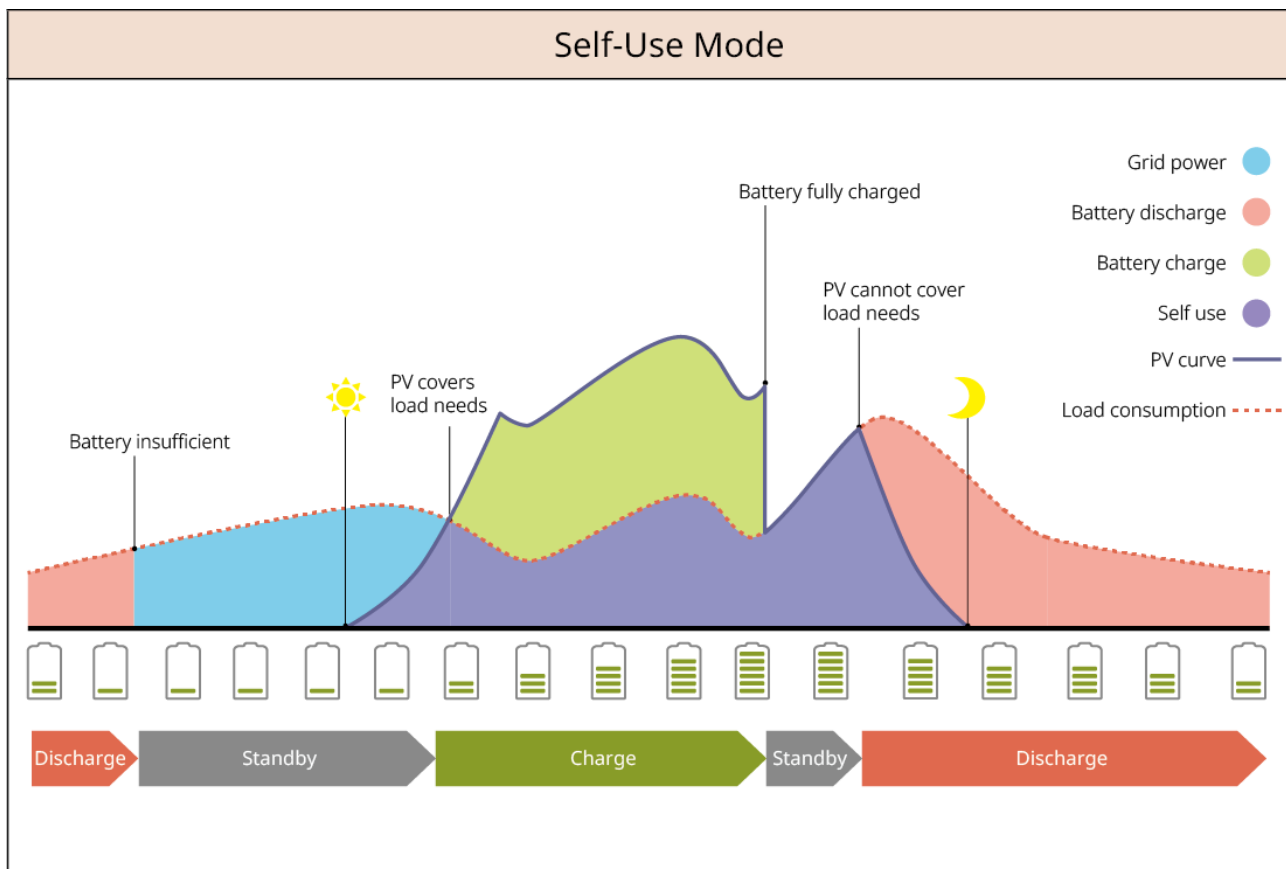

EO20NET0016

Backup Mode

- Recommended for areas with unstable grid power.
- When the grid power fails, the inverter switches to off-grid operation mode, and the battery discharges to supply the load, ensuring uninterrupted power for the BACK-UP load. When grid power is restored, the inverter switches its operation mode back to grid-tied.
- To ensure the battery State of Charge (SOC) is sufficient to maintain normal system operation during off-grid periods, when the system operates in grid-tied mode, the battery will be charged using PV or by purchasing power from the grid until it reaches the Backup Power SOC. If purchasing power from the grid to charge the battery, please ensure compliance with local grid regulations and laws.

Back-up Mode ①

Charging from grid: disabled

Back-up SOC: 60%

Grid connected Grid disconnected Grid connected

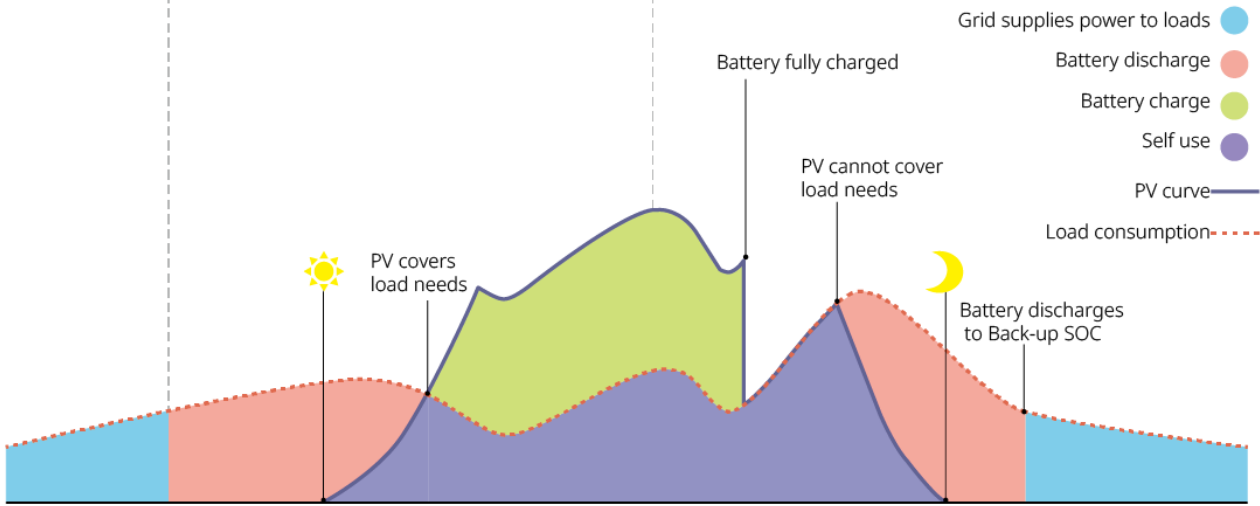

EO20NET0009

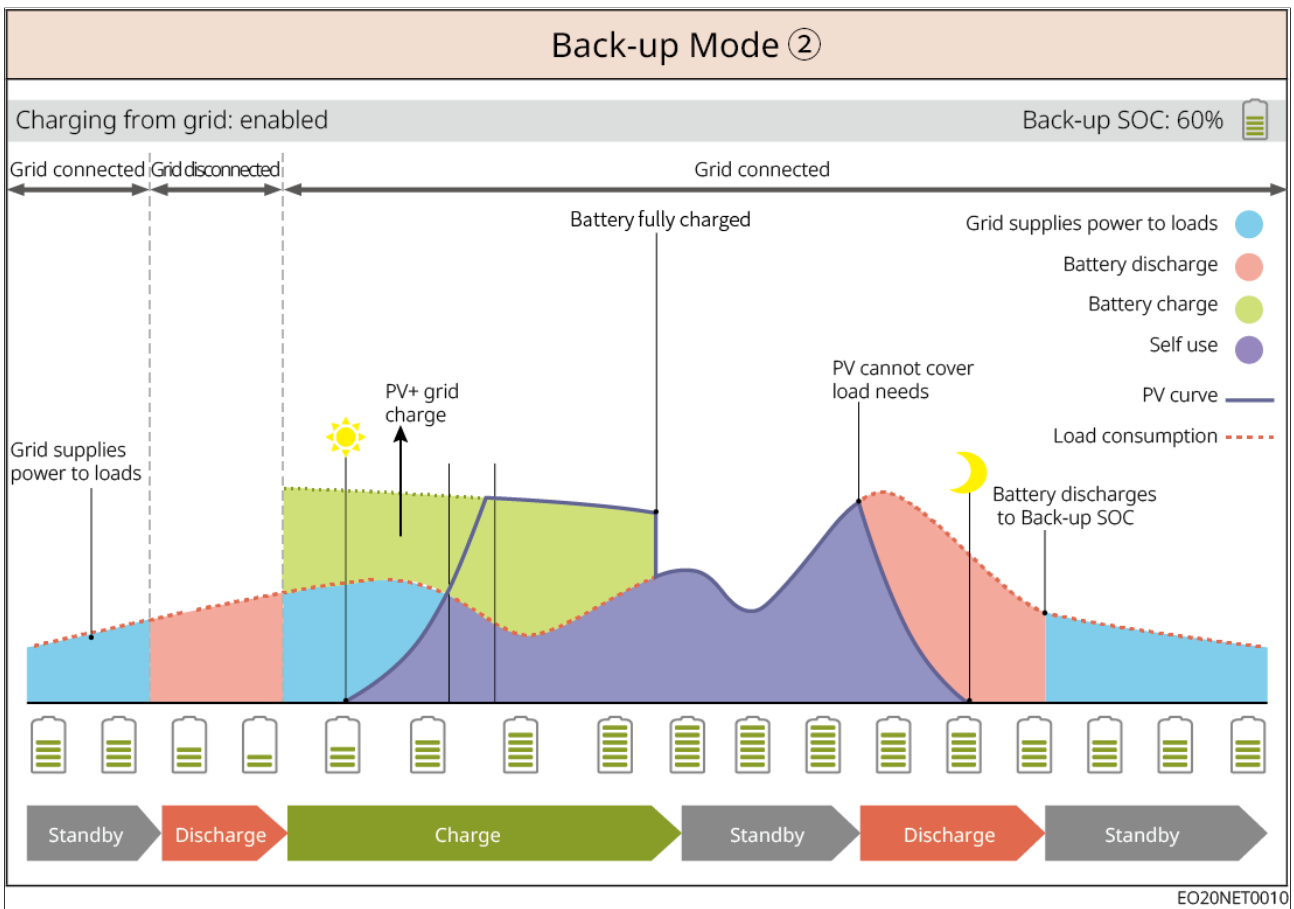

TOU Mode

When permitted by local laws and regulations, configure power purchase from the grid during different time periods based on peak and off-peak electricity price differences.

For example: During off-peak hours, set the battery to charging mode to purchase power from the grid for charging. During peak hours, set the battery to discharging mode to supply the load via the battery.

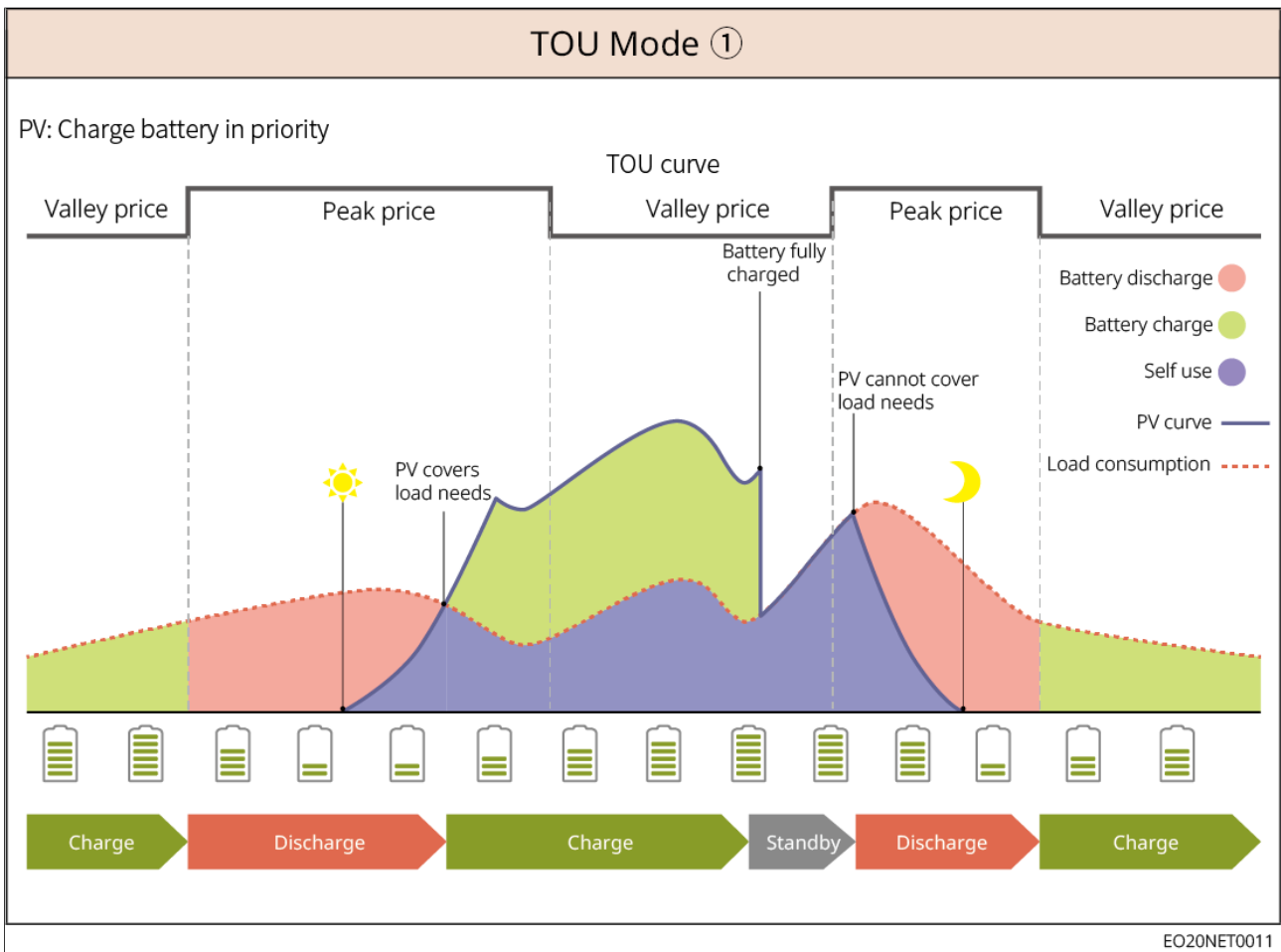

Peakshaving Mode

- Primarily applicable to commercial and industrial scenarios.
- When the total load power consumption exceeds the power quota within a short period, battery discharge can be utilized to reduce the portion of consumption exceeding the quota.
- When the battery SOC is lower than the reserved SOC for demand management, the system purchases power from the grid based on the time period, load consumption, and the peak power purchase limit.

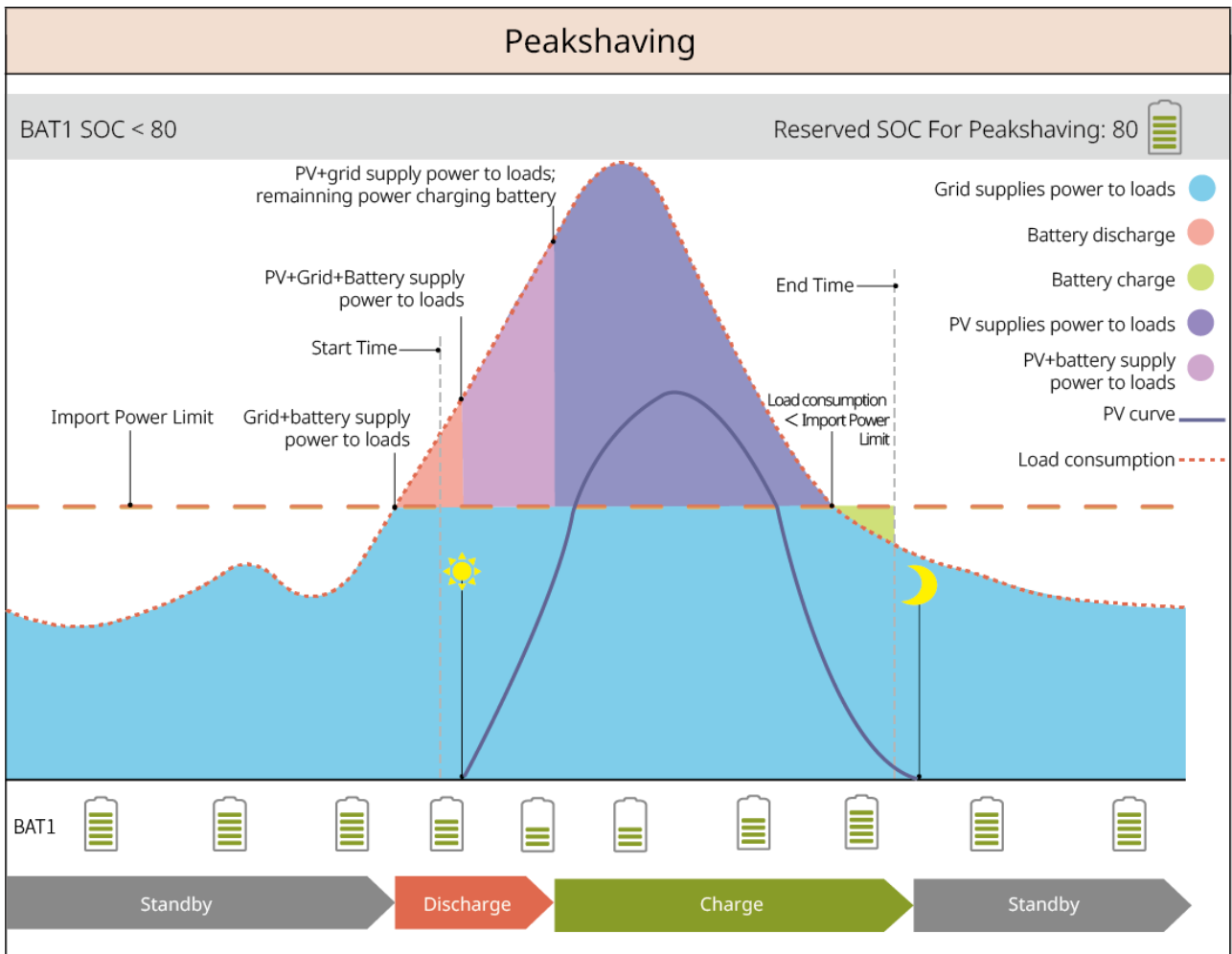

SLG00NET0001

Off-Grid Mode

Note

Do not run the pure off-grid mode when the inverter is not connected to the battery system.

When the grid power fails, the inverter switches to off-grid operation mode.

- During the day, PV-generated power is prioritized for supplying the load, with excess power used to charge the battery.
- At night, the battery discharges to supply the load, ensuring uninterrupted power for the BACK-UP load.

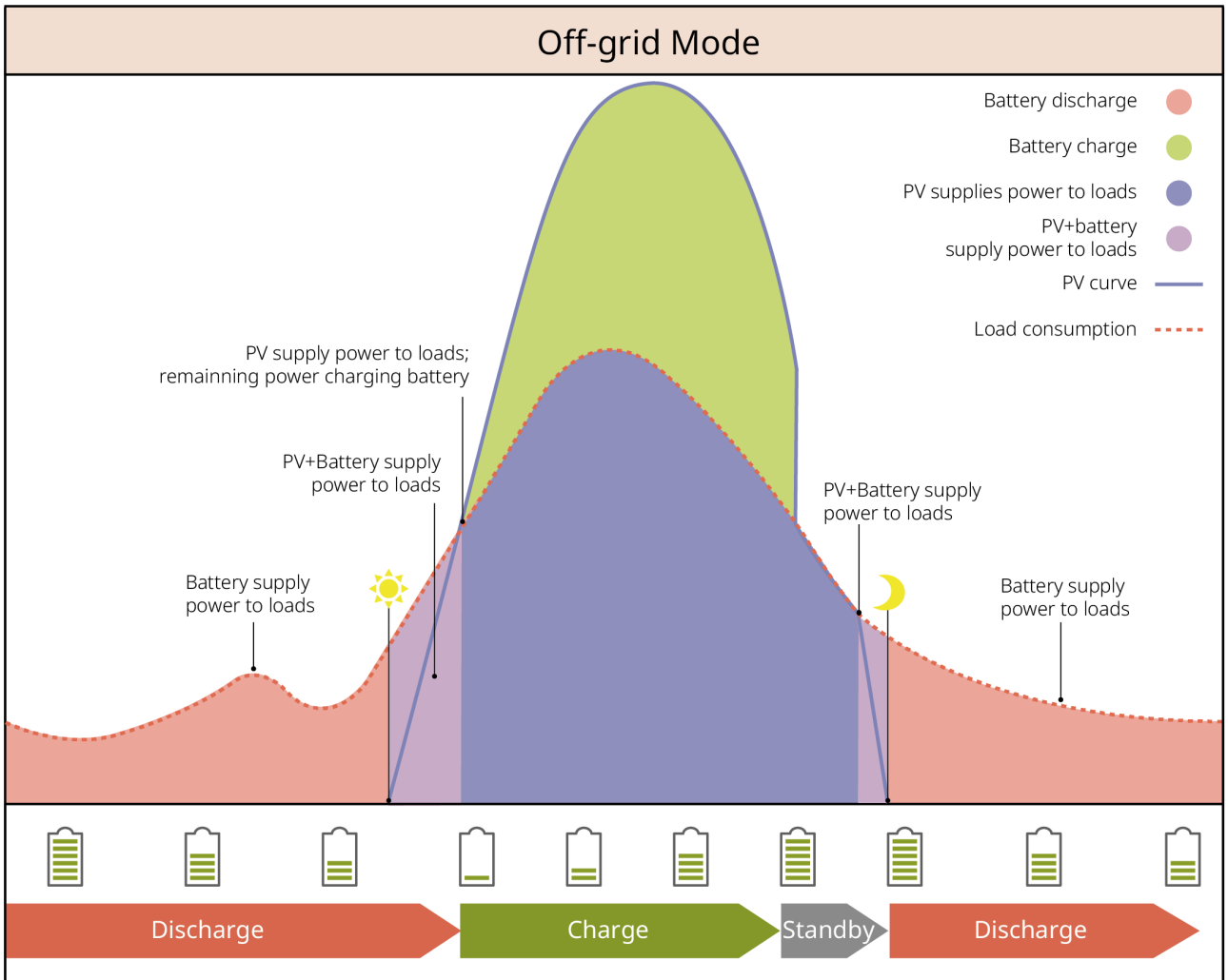

SLG00NET0012

3 Device Inspection and Storage

3.1 Device Inspection

Before signing for the product, please carefully inspect the following:



1. Check the outer packaging for any damage, such as deformation, holes, cracks, or other signs that could indicate damage to the device inside the box. If damage is found, do not open the packaging and contact your dealer.
2. Check if the device model is correct. If it does not match, do not open the packaging and contact your dealer.

3.2 Deliverables

Warning

Check whether the type and quantity of the delivered items are correct and whether there is any visible damage. If damaged, please contact your dealer. After removing the delivered items from the packaging, do not place them on rough, uneven, or sharp surfaces to avoid paint chipping.

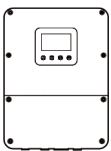
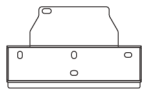
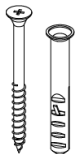







3.2.1 Inverter Deliverables

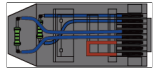
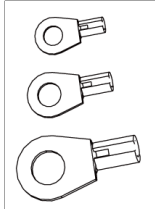



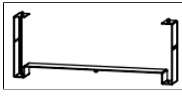

Component	Description	Component	Description
	Inverter x1		Back Mounting Plate x1
	Expansion Screws x4		Protective Grounding Terminal x 1

Component	Description	Component	Description
	Battery Power Connection Terminal x 2		Battery Terminal Fastening Screw
	PV DC Wiring Terminal <ul style="list-style-type: none"> • GW3K-EO-G20, GW3.6K-EO-G20: x 1 • GW5K-EO-G20, GW6K-EO-G20: x 2 		Communication Tubular Terminal x 16
	2PIN Communication Terminal x 1		6PIN Communication Terminal x 2
	AC Tubular Terminal x 10		Flathead Screwdriver x 1
	Communication Outlet Waterproof Plug x 1		BMS Communication Cable x 1
	PV Terminal Fastening/Unlocking Tool x 1		Product Documentation x 1







3.2.2 Battery Deliverables



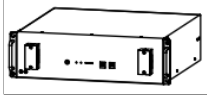
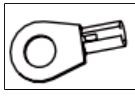

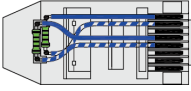
3.2.2.1 LX A5.0-30

Component	Description	Component	Description
	Battery Module x 1		Terminating Resistor x 1 This terminating resistor must be installed on the battery when connecting to a third-party busbar.
	<ul style="list-style-type: none"> • M5 OT Terminal x 2: Recommended for connecting 10mm² cable • M8 OT Terminal x 4: Recommended for connecting 50mm² cable • M10 OT Terminal x 2: Recommended for connecting 70mm² cable 		M5*12 Grounding Screw x 2
	Mounting Bracket x 2 Included when the wall-mount installation option is selected.		M6*70 Expansion Bolt x 4 Included when the wall-mount installation option is selected.
	M5*12 Grounding Screw x 2 Included when the wall-mount installation option is selected.		Marking Template x 1 Included when the wall-mount installation option is selected.
	Battery Stand x 2 (Optional) Included when the stack installation option is selected.		M4*8 Screw x 8 Included when the stack installation option is selected.

Component	Description	Component	Description
	Product Documentation x 1		Negative Power Cable (Optional) x 1
	Positive Power Cable (Optional) x 1		Grounding Cable (Optional) x 1
	Communication Cable (Optional) x 1		Decorative Cover (Optional) x 1

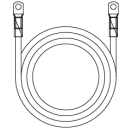
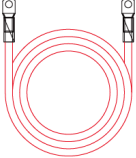
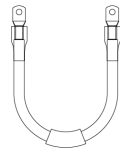
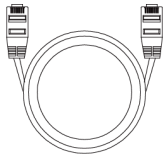
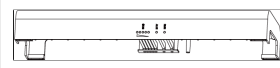

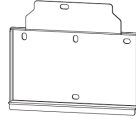

3.2.2.2 LX A5.0-10

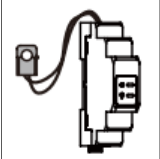

Part	Description	Part	Description
	Battery Module x 1		(25-8) OT Terminal x 4 (5.5-5) OT Terminal x 2
	M5 Grounding Screw x 2		Warning Label x 1
	Terminating Resistor x 1		Electrical Label x 1
	M4*8 Screw x 8 (Optional) Included when bracket installation is selected		Battery Bracket x 2 (Optional) Included when bracket installation is selected

Part	Description	Part	Description
	Product Documentation x 1		Negative Power Cable (Optional) x 1
	Positive Power Cable (Optional) x 1		Grounding Cable (Optional) x 1
	Communication Cable (Optional) x 1		Decorative Cover (Optional) x 1
	Wall Mount Bracket Expansion Screw (Optional) x 4		Wall Mount Bracket (Optional) x 1
	Mounting Bracket (Optional) x 1		Mounting Bracket Screw (Optional) x 4

3.2.3 Smart Meter Deliverables

3.2.3.1 GMK110

Component	Description	Component	Description
	Smart Meter and CT x 1		RS485 Communication Terminal x 1
	Voltage Input Side Terminal Block x 1		Tubular Terminal x 4

Component	Description	Component	Description
	Screwdriver x1		Product Documentation x 1

3.3 Device Storage

If the device is not put into use immediately, store it according to the following requirements. After long-term storage, the device must be inspected and confirmed by qualified personnel before it can be used again.

1. If the inverter is stored for more than two years or remains non-operational for more than 6 months after installation, it is recommended to have it inspected and tested by qualified personnel before putting it into use.
2. To ensure the good electrical performance of the internal electronic components of the inverter, it is recommended to power it on every 6 months during storage. If it has not been powered on for more than 6 months, it is recommended to have it inspected and tested by qualified personnel before use.
3. To ensure battery performance and service life, it is recommended to avoid long-term idle storage. Prolonged storage may cause the battery to deep discharge, leading to irreversible chemical loss, capacity degradation, or even complete failure. Timely use is advised. If the battery requires long-term storage, please maintain it according to the following requirements:

Battery Model	Initial SOC Range for Battery Storage	Recommended Storage Temperature	Charge/Discharge Maintenance Cycle ^[1]	Battery Maintenance Method ^[2]
LX A5.0-10	30%~40%	0~35°C	-20~0°C, ≤1 month 0~35°C, ≤6 months	
n*LX A5.0-10				

LX A5.0-30	30%~40%	0~35°C	-20~45°C, ≤6 months	Please consult the distributor or after-sales service center for maintenance methods.
------------	---------	--------	---------------------	---

Note

[1] The storage time is calculated from the SN date on the battery outer packaging. Charge/discharge maintenance is required after exceeding the storage period. (Battery maintenance time = SN date + charge/discharge maintenance cycle). For the method to view the SN date, refer to: [SN Code Meaning](#).

[2] After passing the charge/discharge maintenance, if the outer box has a Maintaining Label, please update the maintenance information on the Maintaining Label. If there is no Maintaining Label, please record the maintenance time and battery SOC yourself and keep the data properly for maintaining maintenance records.

Packaging Requirements:

Ensure the outer packaging box is not removed and the desiccant inside the box is not missing.

Environmental Requirements:

1. Ensure the device is stored in a cool place, avoiding direct sunlight.
2. Ensure the storage environment is clean, with appropriate temperature and humidity ranges, and free from condensation. If condensation is present on the device ports, do not install the device.
3. Ensure the device is stored away from flammable, explosive, corrosive, and other hazardous materials.

Stacking Requirements:

1. Ensure the stacking height and orientation of the inverter are arranged according to the instructions on the packaging box label.

2. Ensure there is no risk of the inverter stack tipping over.

4 Installation



For equipment installation and electrical connection, please use the delivered components included in the shipment. Otherwise, any resulting equipment damage will not be covered under warranty.

4.1 System Installation and Debugging Process

Steps	1 Installation	2 PE	3 PV	4 Battery	5 AC	6 COM		
Inverter								
Tools	D: 80mm Φ: 8mm	M5 1.5-2N-m		1 M8 5N-m 2 M25 5-6N-m	2 1.5N-m 3 M25 5-6N-m 4 M22 5N-m	2 M2 0.2-0.3N-m 4 M22 5N-m 5 M25 5-6N-m		
Steps	1 Installation					2 PE	3 Battery	4 COM
Battery	LX A5.0-10			LX A5.0-30		LX A5.0-10 LX A5.0-30	LX A5.0-10 LX A5.0-30	LX A5.0-10 LX A5.0-30
Tools			1 D: 80mm Φ: 8mm 2 M6 6N-m 3 M5 4N-m		1 D: 80mm Φ: 8mm 2 M6 6N-m 3 M4 1.4N-m	M5 4N-m	M6 6N-m	M8 12N-m
Steps	1 Installation	2 Cable Connections	3 Power	4 Commissioning				
Smart meter	GMK110	GMK110 0.3-0.5N-m	AC breaker					

EO20INT010

4.2 Installation Requirements

4.2.1 Installation Environment Requirements

1. The device must not be installed in flammable, explosive, corrosive, or similar

environments.

2. The temperature and humidity of the installation environment must be within a suitable range.
3. The installation location must be out of reach of children and avoid easily accessible positions.
4. The inverter enclosure temperature may exceed 60°C during operation. Do not touch the enclosure before it cools down to prevent burns.
5. The device must be installed away from direct sunlight, rain, snow accumulation, etc. It is recommended to install in a sheltered location; a sunshade can be built if necessary.
6. The installation space must meet the ventilation, heat dissipation, and operational space requirements of the device.
7. The installation environment must satisfy the device's ingress protection (IP) rating. The inverter, battery, and smart communication stick are suitable for indoor and outdoor installation; the meter is for indoor installation only.
8. The installation height of the device should facilitate operation and maintenance, ensuring device indicator lights, all labels are easily visible, and wiring terminals are easily accessible.
9. The installation altitude must be lower than the maximum operating altitude.
10. For outdoor installation in salt damage areas, consult the device manufacturer. Salt damage areas mainly refer to regions within 500m of the coastline. The affected area is related to sea wind, precipitation, terrain, and other conditions.
11. Keep away from strong magnetic field environments to avoid electromagnetic interference. If there are radio stations or wireless communication equipment operating below 30MHz near the installation site, install the device according to the following requirements:
 - Inverter: Add ferrite cores with multiple turns on the inverter DC input lines or AC output lines, or add a low-pass EMI filter; OR ensure the distance between the inverter and the wireless electromagnetic interference source exceeds 30m.
 - Other devices: Ensure the distance between the device and the wireless electromagnetic interference source exceeds 30m.
12. The length of the DC cables and communication cables between the battery and inverter must be less than 3m. Ensure the installation distance between the inverter and battery meets the cable length requirement.

Notice

If installed in an environment below 0°C, the battery may be unable to recharge and restore energy after being depleted, resulting in battery undervoltage protection.

- LX A5.0-30: Charging temperature range: 0°C < T ≤ 55°C; Discharging temperature range: -20°C < T ≤ 55°C
- LX A5.0-10: Charging temperature range: 0°C < T ≤ 50°C; Discharging temperature range: -10°C < T ≤ 50°C

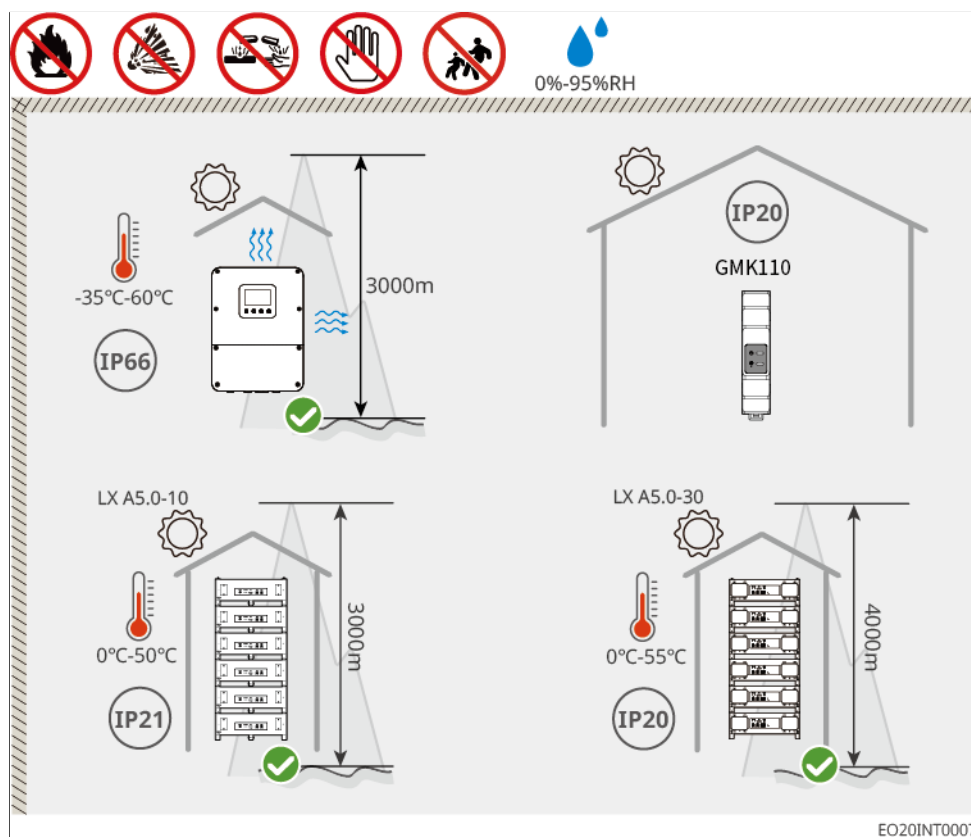

4.2.2 Installation Space Requirements

When installing the equipment within the system, sufficient space should be reserved around the device to ensure adequate room for installation and heat dissipation.

- Installing the CT requires using a CAT5E or higher shielded network cable, with a cable distance not exceeding 30 meters.
- The RS485 twisted-pair shielded cable for communication between the inverter and

the electricity meter should not exceed 100 meters in length.

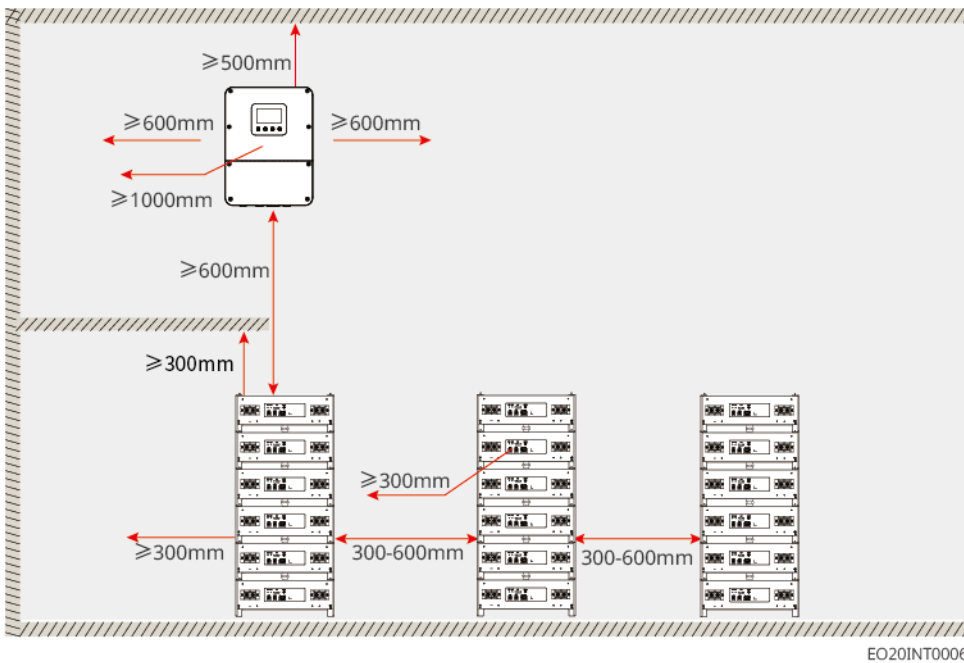

Cable Length Requirements

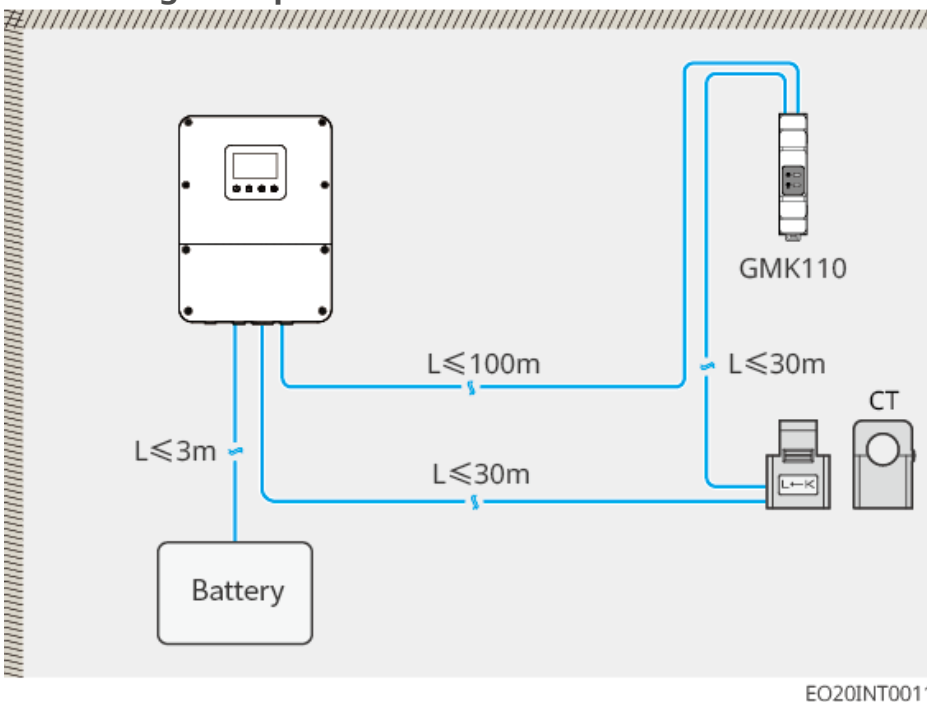













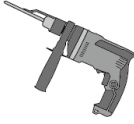
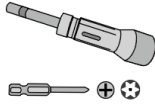

4.2.3 Tool Requirements

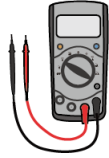
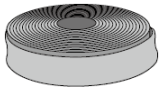

Note

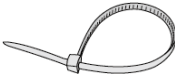
It is recommended to use the following installation tools. Other auxiliary tools may be used on-site if necessary.

Installation Tools

Tool Type	Description	Tool Type	Description
	Diagonal Cutters		RJ45 Crimping Tool
	Wire Strippers		Level
	Open-End Wrench		PV Terminal Crimping Tool A-2546B
	Hammer Drill (Bit Φ8mm)		Torque Wrench M4, M5, M8
	Rubber Mallet		Socket Wrench Set
	Marker Pen		Multimeter Range ≤600V
	Heat Shrink Tubing		Heat Gun
	Cable Ties		Vacuum Cleaner

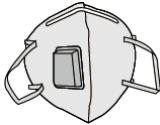
Personal Protective Equipment

Tool Type	Description	Tool Type	Description
	Insulating gloves, protective gloves		Dust mask
	Safety goggles		Safety shoes

4.3 Equipment Relocation

Caution

- During operations such as transportation, handling, and installation, the laws, regulations, and relevant standards of the country or region must be complied with.
- Before installation, the equipment needs to be moved to the installation site. To avoid personal injury or equipment damage during the moving process, please note the following:
 1. Ensure the number of personnel matches the weight of the equipment to prevent it from exceeding the safe manual handling limit and causing injury.
 2. Wear safety gloves to avoid injury.
 3. Keep the equipment balanced during movement to prevent it from falling.

4.4 Install Inverter

⚠ Caution

- When drilling holes, ensure the drilling location avoids water pipes, cables, etc., inside the wall to prevent hazards.
- Wear safety goggles and a dust mask when drilling to avoid inhaling dust into the respiratory tract or getting it in the eyes.
- Ensure the inverter is securely installed to prevent it from falling and causing injury.

1. Place the back mounting plate horizontally on the wall, and use a marker pen to mark the drilling positions.
2. Use an impact drill to drill the holes.
3. Use expansion screws to fix the inverter back mounting plate bracket to the wall.
4. Hang the inverter on the back plate. After hanging, install the anti-theft lock.

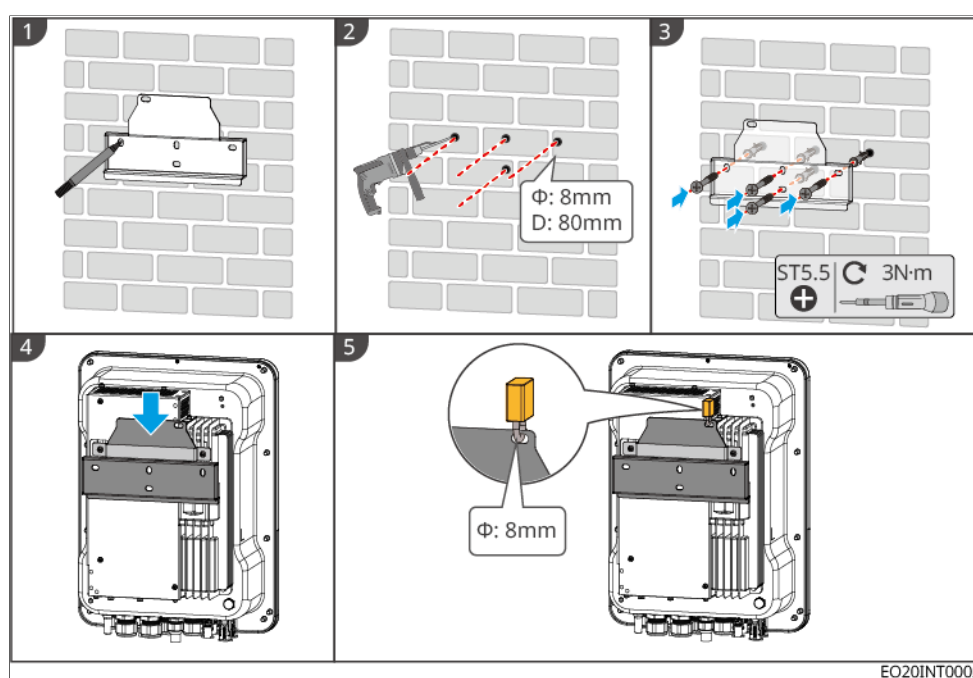

4.5 Installing Batteries

⚠ Warning

- During battery system installation, ensure it is level and securely mounted. When using an anti-tipping bracket, the bracket must be vertical and flush against both the wall and the battery system surface.
- When using an impact drill to create holes, shield the battery system with cardboard or other coverings to prevent debris from entering the device and causing damage.
- After marking the drilling positions with a marker, move the battery system away to avoid damaging the device if the impact drill operates too close to it during drilling.

4.5.1 LX A5.0-30

LX A5.0-30: Floor Stacking Installation

Note

Ground stacking supports a maximum of 6 batteries stacked

1. Place the battery vertically and remove the battery handle.
2. Install the bracket onto the battery and secure it with screws.
3. Lay the battery flat and stack multiple batteries for installation. Ensure the locating pins are inserted into the locating holes.

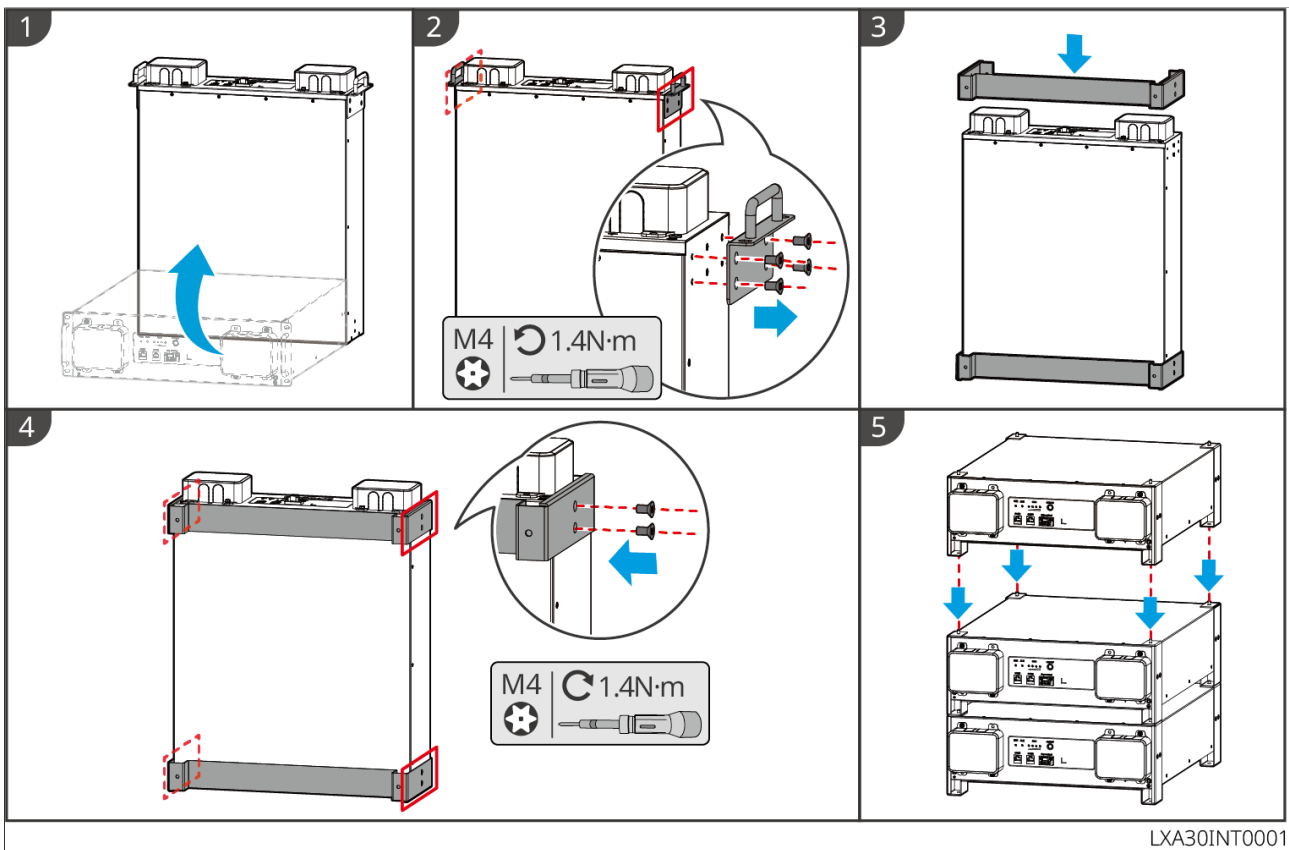

LX A5.0-30: Cabinet Installation

Note

- Recommended for installation in a standard 19-inch cabinet, dimensions (L*W): 600*800mm or larger, height: select based on the battery thickness (133mm) or greater.
- For cabinet installation, an electrical label and a warning label must be affixed to the front panel of any one battery (these labels are shipped as additional accessories).

1. Place the battery onto the cabinet rails and secure the battery to the cabinet with screws from the handle position.

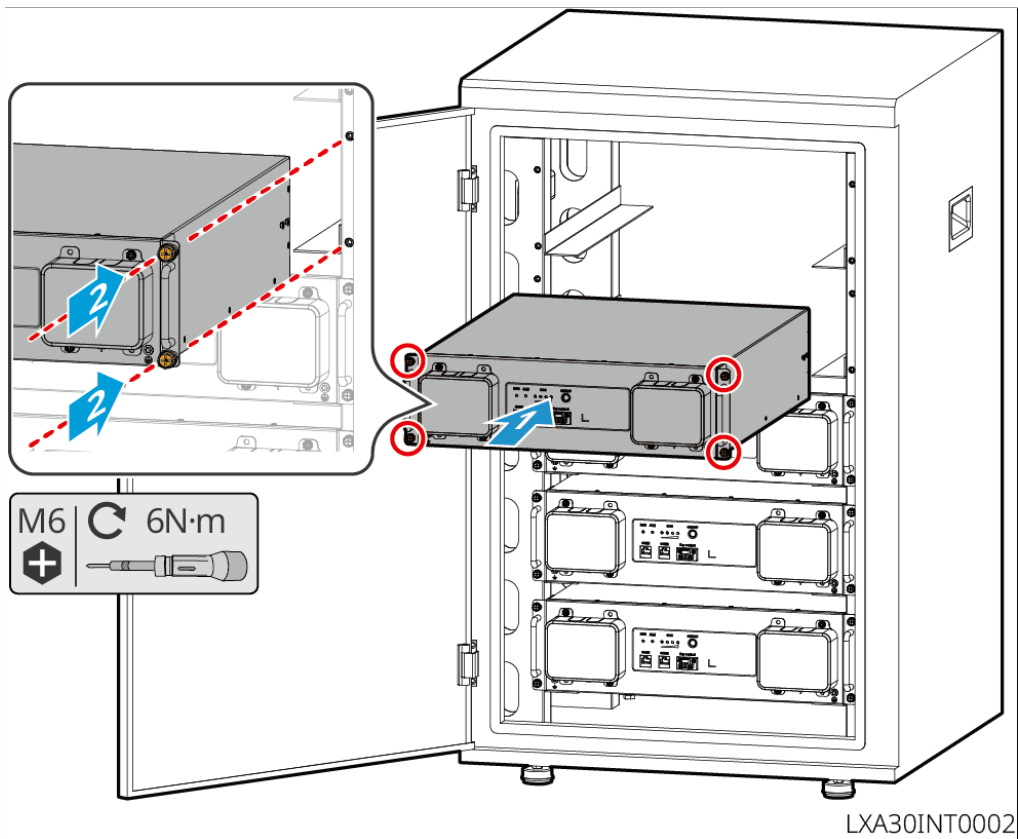

LX A5.0-30: Wall Mount Installation

1. Determine the drilling positions according to the marking template and mark them with a marker pen.
2. Drill holes using an impact drill.
3. Install the battery wall mount bracket.
4. Mount the battery onto the bracket and securely connect the battery and the bracket with screws.

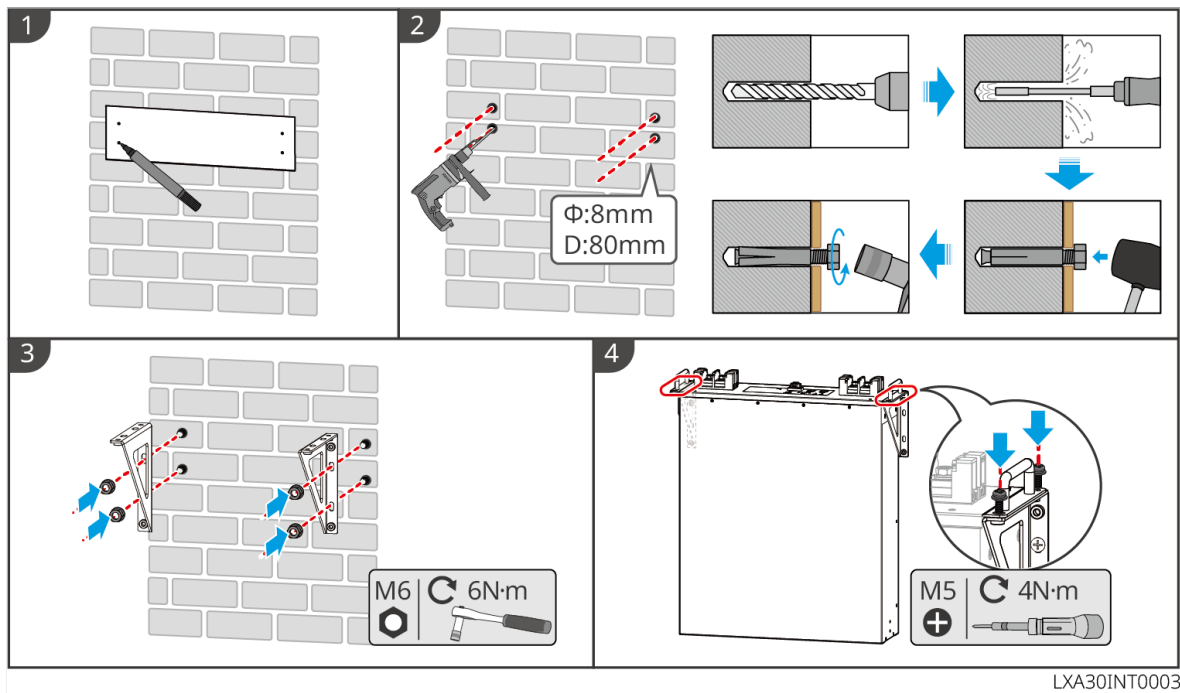

4.5.2 LX A5.0-10

LX A5.0-10: Floor Stacking

Note

A floor stack can hold a maximum of 6 batteries.

1. Place the battery vertically.
2. Place the bracket onto the battery and remove the handle from the battery.
3. Place another bracket onto the battery.
4. Secure the brackets to the battery with screws, and lay the battery down flat.
5. Stack and install multiple batteries.
 - Align the alignment pins on the lower battery bracket with the alignment holes on the upper battery bracket, and insert the pins into the holes.

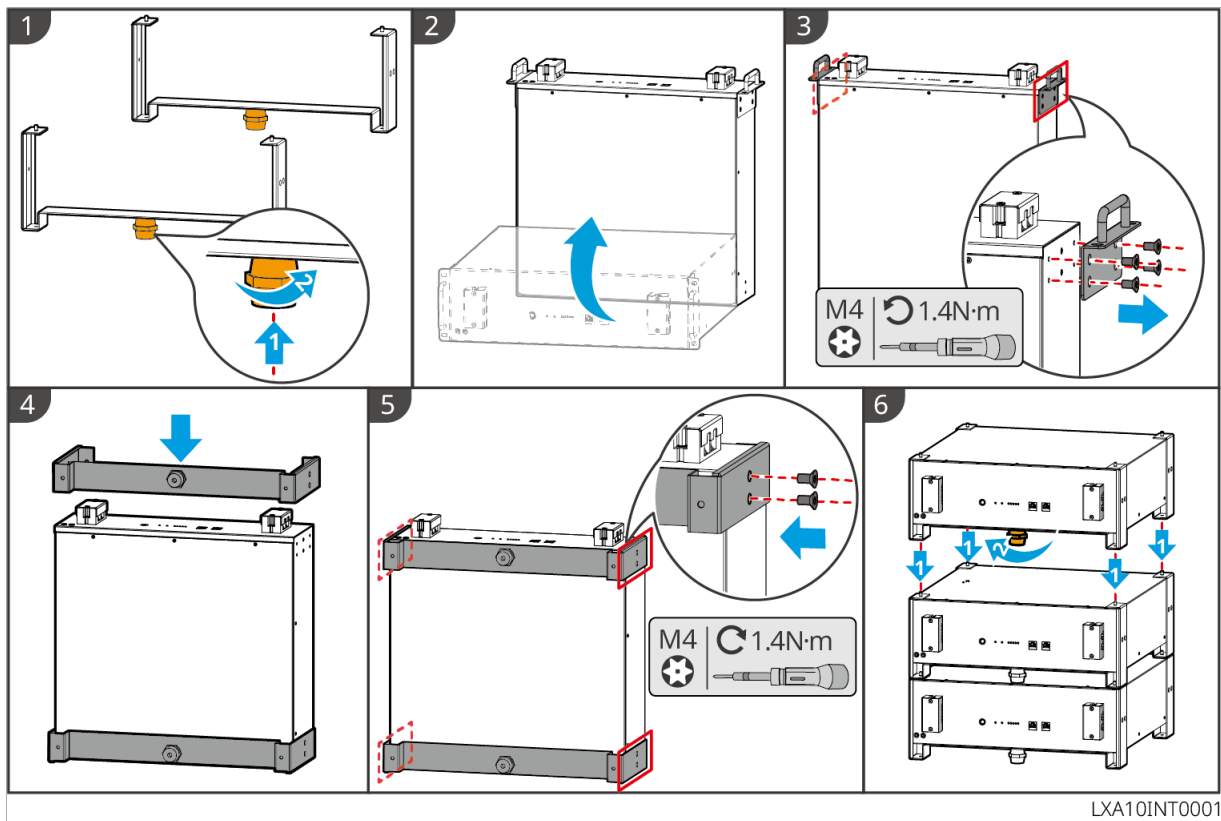

LXA10INT0001

LX A5.0-10: Cabinet Installation

Note

- Recommend a 19-inch standard cabinet. Physical dimensions: length and width can be 600*800mm or larger; height can be selected according to the number of parallel batteries.
- For cabinet installation, electrical labels and warning labels must be affixed to the front panel of any battery (these labels are shipped as additional accessories).

1. Affix the electrical label and warning label to any position on the front panel of a battery.
2. Place the battery onto the rails inside the cabinet, and secure the battery to the cabinet with screws through the handle.

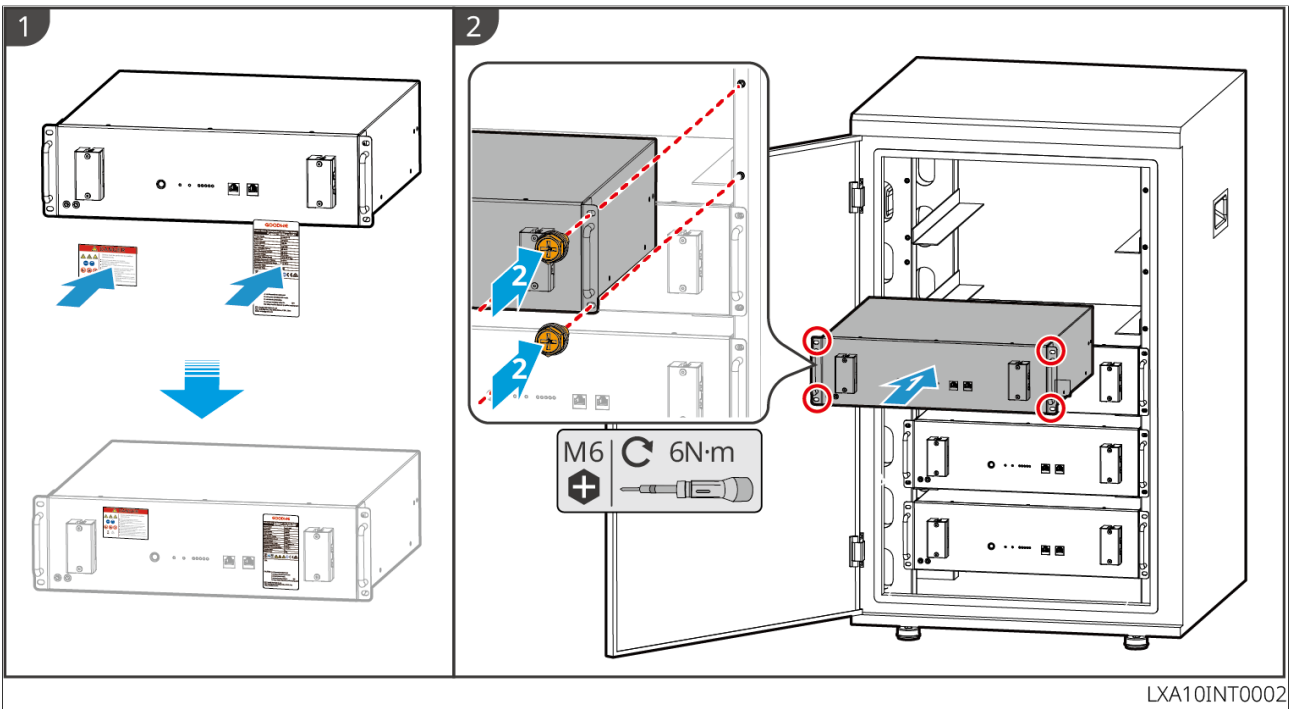

LX A5.0-10: Wall Mount Installation

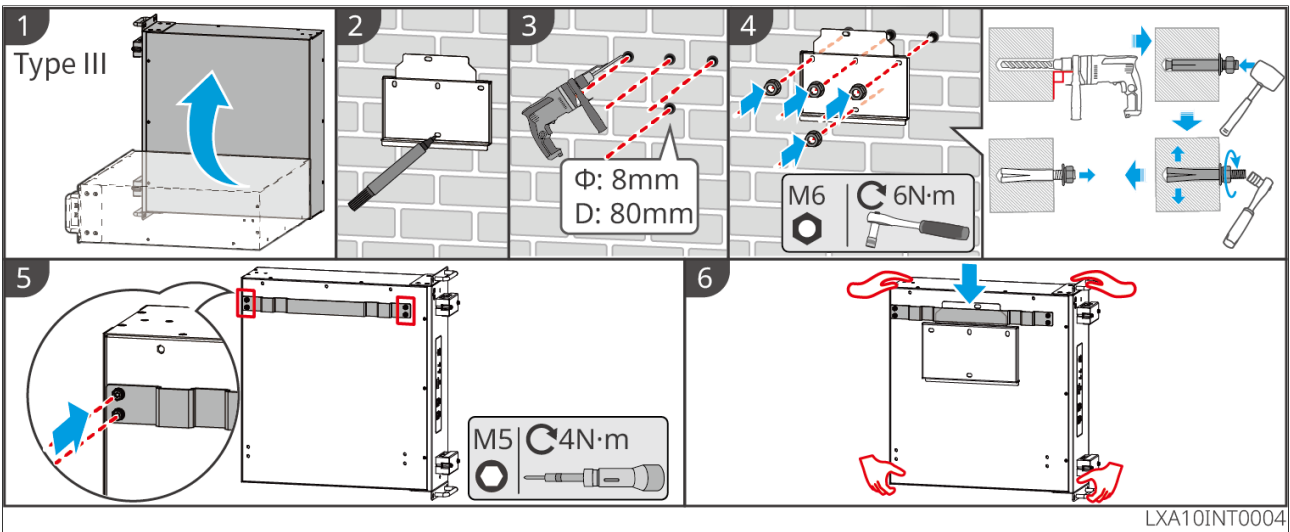

4.6 Installation of Electricity Meter



In areas with a lightning hazard, if the meter cable length exceeds 10m and the cable is not routed using a grounded metal conduit, it is recommended to install an external lightning protection device.

GMK110

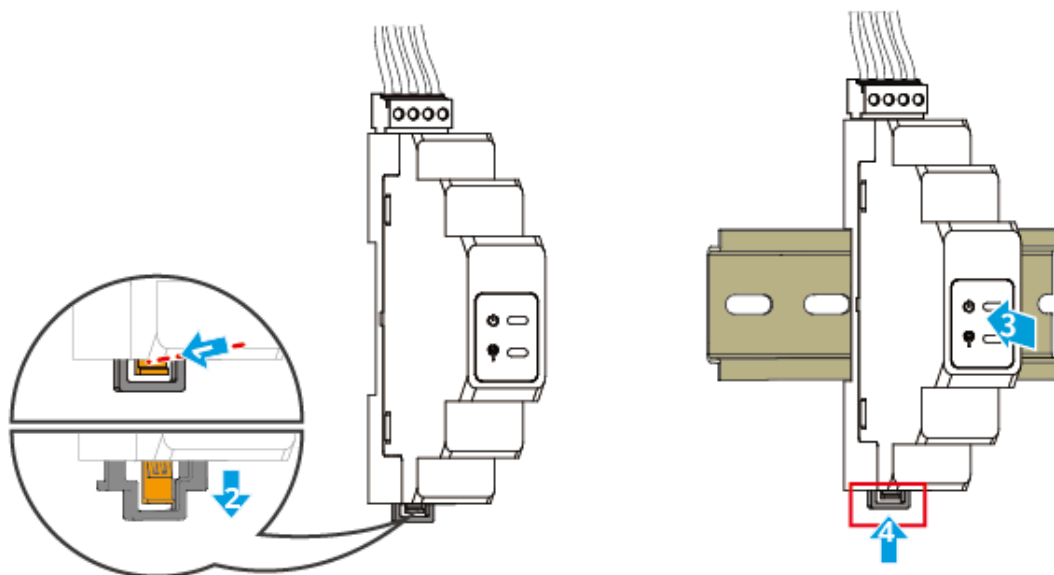

5 System Wiring

Danger

- The installation, routing, and connection of cables must comply with local laws, regulations, and code requirements.
- All operations during electrical connection, as well as the specifications of cables and components used, must meet local legal and regulatory requirements.
- Before performing electrical connections, disconnect the DC switch and AC output switch of the equipment to ensure it is powered off. Never perform operations on live circuits, as this may lead to hazards such as electric shock.
- Cables of the same type should be bundled together and separated from different types of cables. They must not be intertwined or cross-routed.
- If the cable is subjected to excessive tension, it may result in poor connections. When wiring, leave a certain length of slack in the cable before connecting it to the inverter terminals.
- When crimping terminals, ensure the conductor part of the cable makes full contact with the terminal. Do not crimp the cable insulation together with the terminal, as this may cause the equipment to malfunction, or lead to overheating due to unreliable connections after operation, potentially damaging the inverter terminal block.

Note

- When performing electrical connections, please wear personal protective equipment such as safety shoes, protective gloves, insulating gloves, etc., as required.
- Only qualified personnel are allowed to perform electrical connection operations.
- The cable colors in the diagrams in this document are for reference only. Specific cable specifications must comply with local regulations.
- For parallel systems, please observe the safety precautions in the user manuals corresponding to the related products in the system.

5.1 System Wiring Electrical Block Diagram

Note

- Depending on regional regulatory requirements, the wiring methods for the N and PE lines of the inverter's ON-GRID and BACK-UP ports differ. Please refer to local regulations for specifics.
- The inverter's ON-GRID AC port has a built-in relay. When the inverter is in off-grid mode, the built-in ON-GRID relay is open; when the inverter is in grid-connected operation mode, the built-in ON-GRID relay is closed.
- After the inverter is powered on, the BACK-UP AC port is live. If maintenance is required on the BACK-UP load, please power off the inverter to avoid electric shock.

N and PE lines are separately connected in the distribution box.

Note

- Ensure the protective ground wire for BACK-UP is correctly and securely connected. Otherwise, the BACK-UP function may operate abnormally in the event of a grid fault.
- The following wiring method applies to regions other than Australia, New Zealand, etc.:

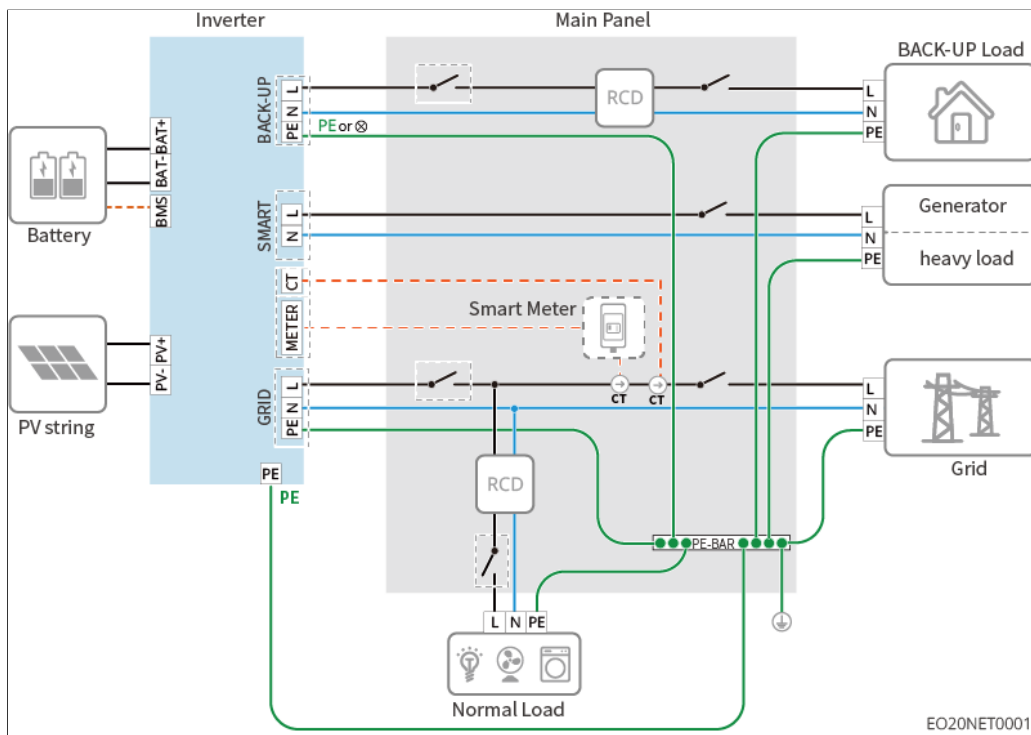

5.2 System Wiring Diagram

5.2.1 Single-Unit System Wiring Detailed Diagram

Whole-House Backup Scenario

Whole-house backup refers to the scenario where, during a grid outage, the energy storage system can seamlessly take over all loads, achieving continuous and stable power supply for the entire house, ensuring all electrical appliances are unaffected by grid fluctuations.

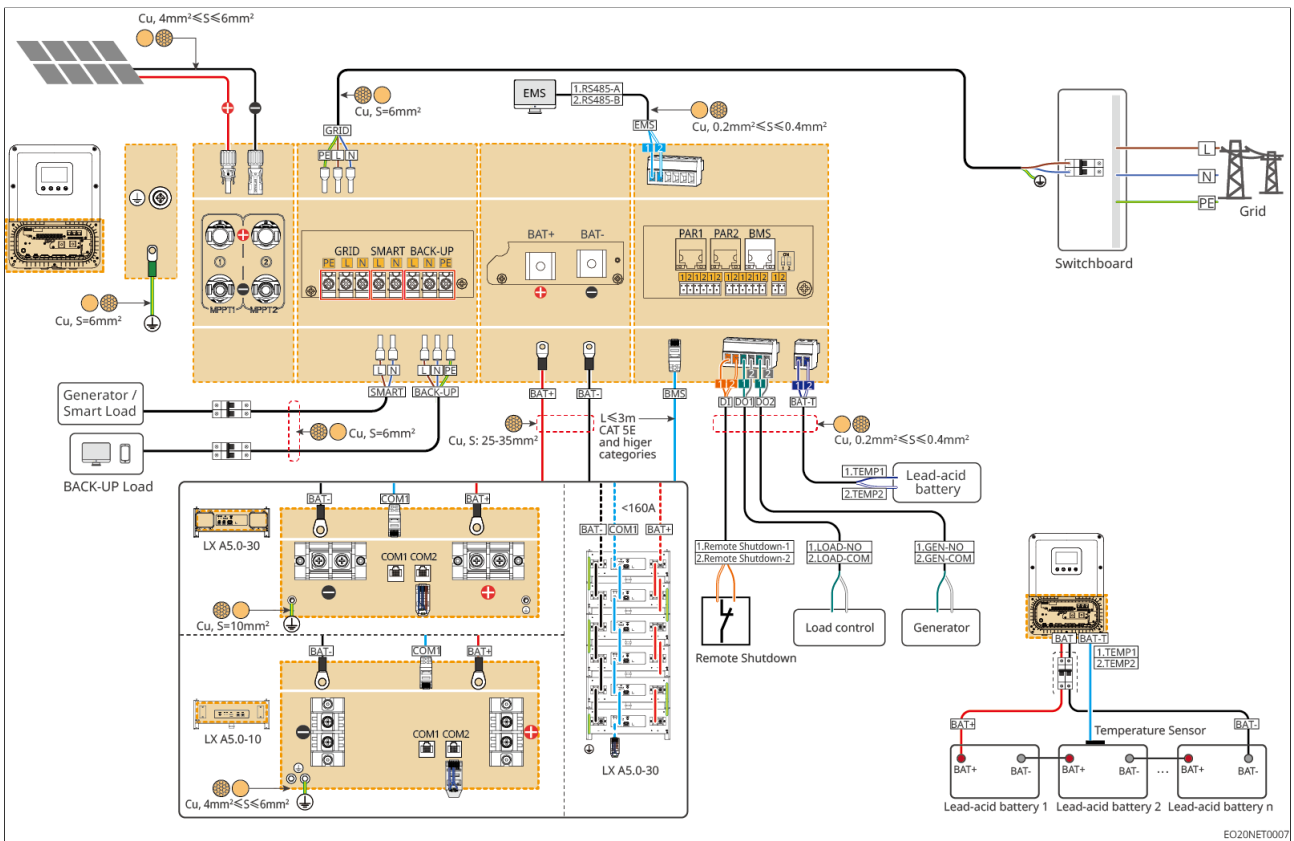

Partial Backup Scenario

Partial backup refers to the scenario where, during a grid outage, the energy storage system only ensures the operation of loads connected to the backup (BACK-UP) and smart (SMART) ports, while loads connected to the grid (GRID) port will not function. To achieve precise load management and scheduling, this system requires an external CT or smart meter to monitor the power consumption of grid-side loads in real-time.

Scenario with CT

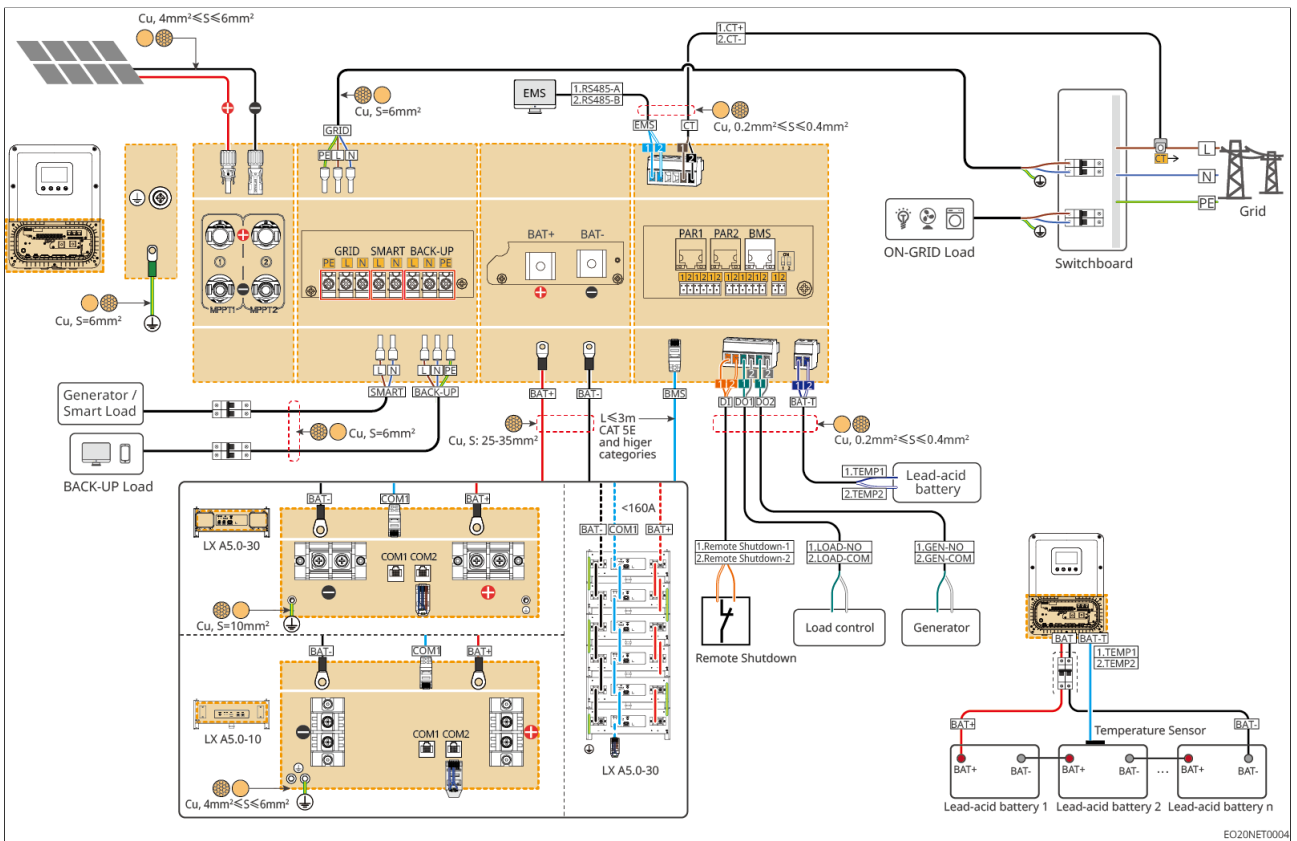

Scenario with GMK110

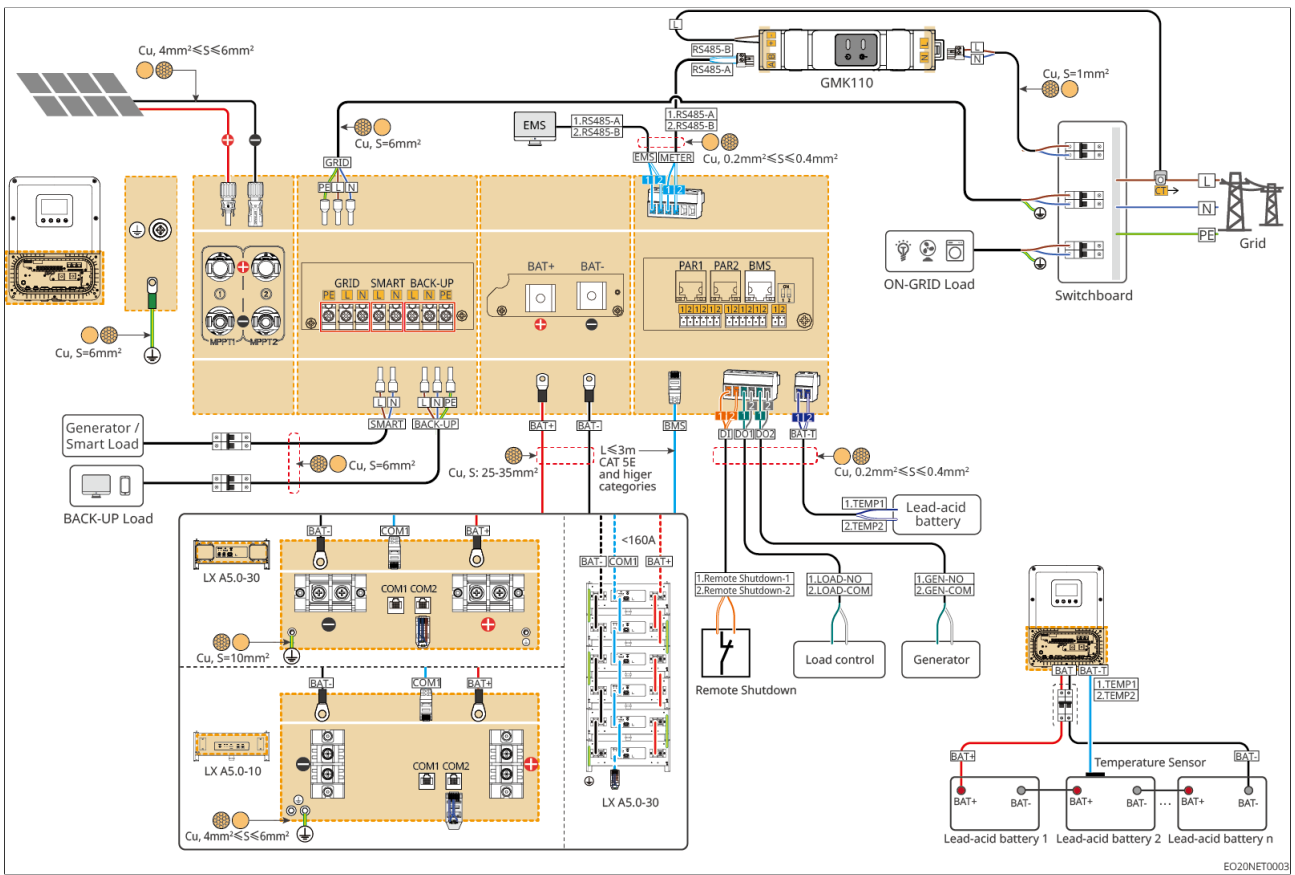

5.3 Material Preparation

 **Warning**

- Do not connect loads between the inverter and the AC switch directly connected to the inverter.
- Each inverter must be equipped with a dedicated AC output circuit breaker. Multiple inverters must not share a single AC circuit breaker.
- To ensure the inverter can be safely disconnected from the grid in case of an abnormality, an AC circuit breaker must be installed on the AC side of the inverter. Select a suitable AC circuit breaker according to local regulations.
- When the inverter is powered on, the BACK-UP AC port is live. If maintenance on the BACK-UP load is required, power down the inverter first; otherwise, electric shock may occur.
- For cables used within the same system, ensure consistency in conductor material, cross-sectional area, length, etc., for the power cables between batteries and batteries.

5.3.1 Switch Preparation

No.	Circuit Breaker	Recommended Specifications	Remarks
1	<ul style="list-style-type: none">• ON-GRID Circuit Breaker• BACK-UP Load Circuit Breaker• SMART Circuit Breaker	<ul style="list-style-type: none">• GW3K-EO-G20, GW3.6K-EO-G20: Rated current $\geq 40A$, Rated voltage $\geq 230V$• GW5K-EO-G20, GW6K-EO-G20: Rated current $\geq 50A$, Rated voltage $\geq 230V$	Customer-provided

No.	Circuit Breaker	Recommended Specifications	Remarks
2	Battery Switch	<p>Select according to local laws and regulations</p> <ul style="list-style-type: none"> • GW3K-EO-G20: Rated current $\geq 90A$, Rated voltage $\geq 60V$ • GW3.6K-EO-G20: Rated current $\geq 115A$, Rated voltage $\geq 60V$ • GW5K-EO-G20: Rated current $\geq 150A$, Rated voltage $\geq 60V$ • GW6K-EO-G20: Rated current $\geq 175A$, Rated voltage $\geq 60V$ 	Customer-provided
3	Residual Current Protection Device	<p>RCD Device Installation and RCD Specification Selection: It is recommended to install an external Type A RCD with a residual current trip level $\geq 300mA$ on the AC output side of the inverter (for inverter capacity $< 30kVA$, select a residual current trip level of $300mA$; for inverter capacity $\geq 30kVA$, select a residual current trip level of $10mA/kVA$). Alternatively, select the appropriate RCD specification according to local regulatory requirements.</p>	Customer-provided

5.3.2 Cable Preparation

No.	Cable	Recommended Specifications	Acquisition Method
1	Inverter Protective Ground Cable	<ul style="list-style-type: none"> • Single-core outdoor copper cable • Conductor cross-sectional area: $S=6mm^2$ 	User-supplied
2	Battery Protective Ground Cable	<ul style="list-style-type: none"> • Single-core outdoor copper cable • Conductor cross-sectional area: <ul style="list-style-type: none"> • LX A5.0-10: $4-6mm^2$ • LX A5.0-30: $10mm^2$ 	LX A5.0-30, LX A5.0-10: Included with accessories (optional)

No.	Cable	Recommended Specifications	Acquisition Method
3	PV DC Cable	<ul style="list-style-type: none"> • Industry-standard outdoor PV cable • Conductor cross-sectional area: 4-6mm² • Cable outer diameter: 4mm-7mm 	User-supplied
4	Battery DC Cable	<ul style="list-style-type: none"> • Single-core outdoor copper cable • Inverter battery terminal connection requirements: <ul style="list-style-type: none"> ◦ Conductor cross-sectional area: 25-35mm² ◦ Cable outer diameter: 8-13mm 	<ul style="list-style-type: none"> • LX A5.0-30, LX A5.0-10: Included with accessories (optional)
5	AC Cable	<ul style="list-style-type: none"> • Inverter AC Input/Output Cable (BACK-UP/GRID): <ul style="list-style-type: none"> ◦ Conductor cross-sectional area: 6mm² ◦ Multi-core outdoor copper cable outer diameter: 14-16mm • SMART Cable: <ul style="list-style-type: none"> ◦ Conductor cross-sectional area: 6mm² ◦ Multi-core outdoor copper cable outer diameter: 13mm-15mm 	User-supplied
6	Smart Meter Power Cable	<ul style="list-style-type: none"> • Outdoor copper cable • Conductor cross-sectional area: 1mm² 	User-supplied
7	Battery Communication Cable	CAT 5E or higher standard shielded Ethernet cable and shielded RJ45 connectors are required for communication between batteries.	<ul style="list-style-type: none"> • User-supplied • LX A5.0-10, LX A5.0-30: Included with accessories (optional)

No.	Cable	Recommended Specifications	Acquisition Method
8	Meter RS485 Communication Cable	<ul style="list-style-type: none"> Shielded twisted pair Conductor cross-sectional area: 0.2mm²-0.4mm² 	User-supplied
9	DO/DI/CT Communication Cable	<ul style="list-style-type: none"> Copper twisted pair Conductor cross-sectional area: 0.2mm²-0.4mm² 	User-supplied

5.4 Removing the Inverter Enclosure Bottom Cover

Warning

- Use the specified tool (wrench) to open the lower enclosure cover of the inverter. The removed cover, wrench, and fastening screws should be properly stored for subsequent reinstallation.
- It is prohibited to open the cover during rain or snow. If opening is absolutely necessary under special circumstances, reliable protective measures (such as setting up a temporary rain shelter) must be taken to ensure rain or snow does not enter the maintenance cavity; otherwise, operation is strictly forbidden.
- Do not open the upper enclosure cover of the inverter.

Remove the inverter enclosure bottom cover:

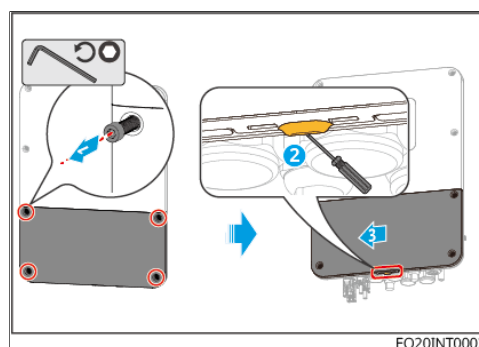

(Optional) Using the cable gland unlocking tool:

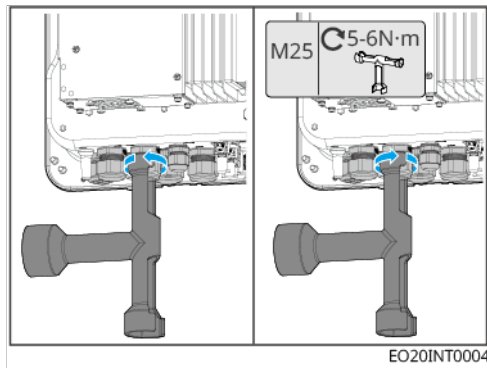

5.5 Connecting the Protective Ground Wire

⚠ Warning

- The protective grounding of the chassis cannot replace the protective ground wire of the AC output port. When wiring, ensure the protective ground wires at both locations are reliably connected.
- When using multiple devices, ensure all protective grounding points on the device chassis are equipotentially connected.
- To improve the corrosion resistance of the terminal, it is recommended to apply silicone sealant or paint over the external part of the grounding terminal for protection after the protective ground wire connection is installed.
- When installing the device, the protective ground wire must be connected first; when removing the device, the protective ground wire must be removed last.

Inverter

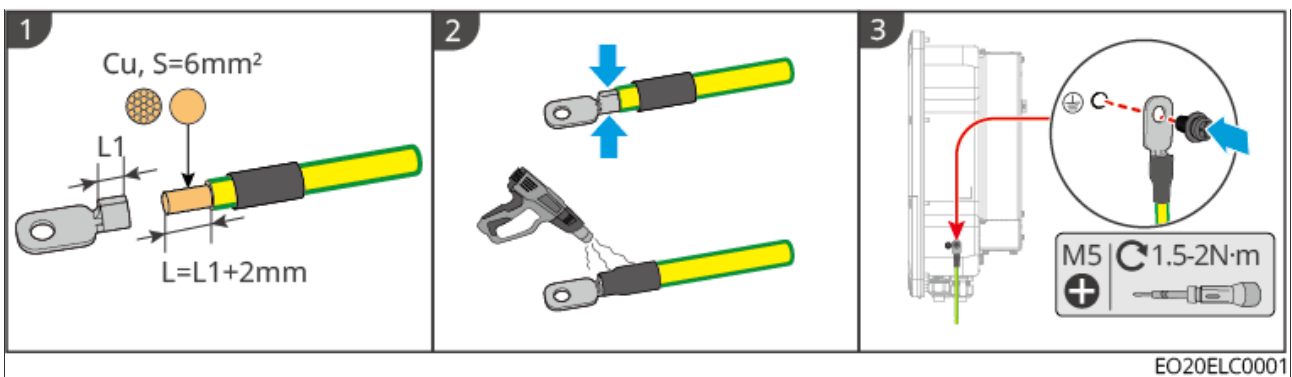

Battery

LX A5.0-10

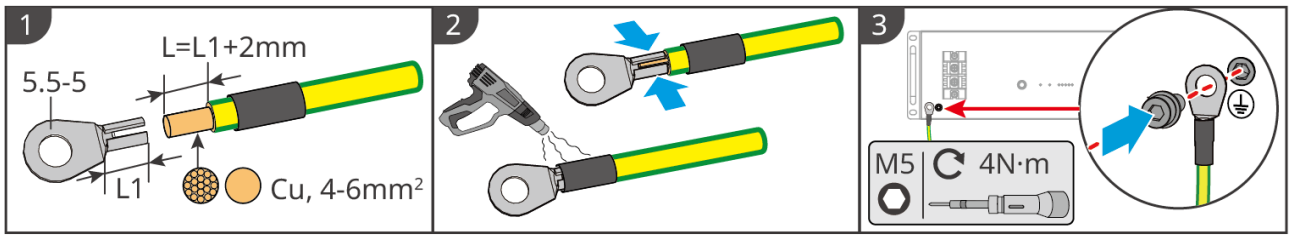

LXA10ELC003

LX A5.0-30

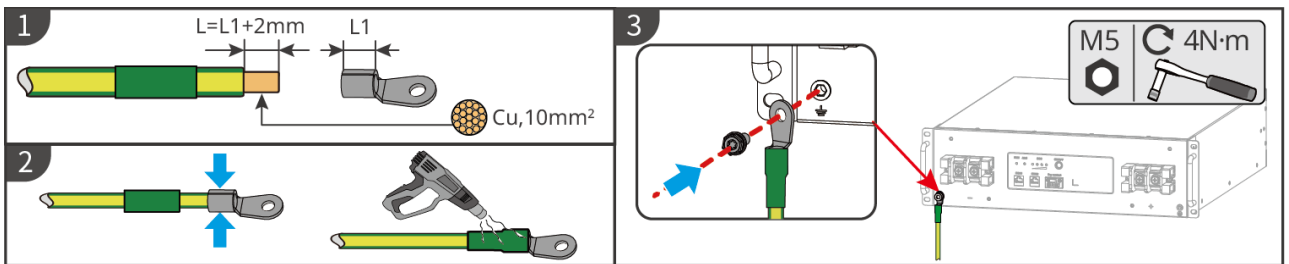

LXA30ELC001

5.6 Connecting PV Cables

⚠ Danger

- Do not connect the same PV string to multiple inverters, as this may cause inverter damage.
- Before connecting the PV string to the inverter, confirm the following information. Failure to do so may cause permanent inverter damage, and in severe cases, may lead to fire, resulting in personal injury and property loss.
 1. Ensure the maximum short-circuit current and maximum input voltage for each MPPT are within the inverter's allowable range.
 2. Ensure the positive terminal of the PV string is connected to the inverter's PV+ terminal, and the negative terminal of the PV string is connected to the inverter's PV- terminal.

⚠ Warning

- PV string output does not support grounding. Before connecting the PV string to the inverter, ensure the minimum insulation resistance to ground of the PV string meets the minimum insulation impedance requirement ($R = \text{Maximum Input Voltage} / 30\text{mA}$).
- After completing the DC cable connection, ensure the cable connections are secure and not loose.
- Use a multimeter to measure the positive and negative poles of the DC cable to ensure correct polarity (no reverse connection) and that the voltage is within the allowable range.

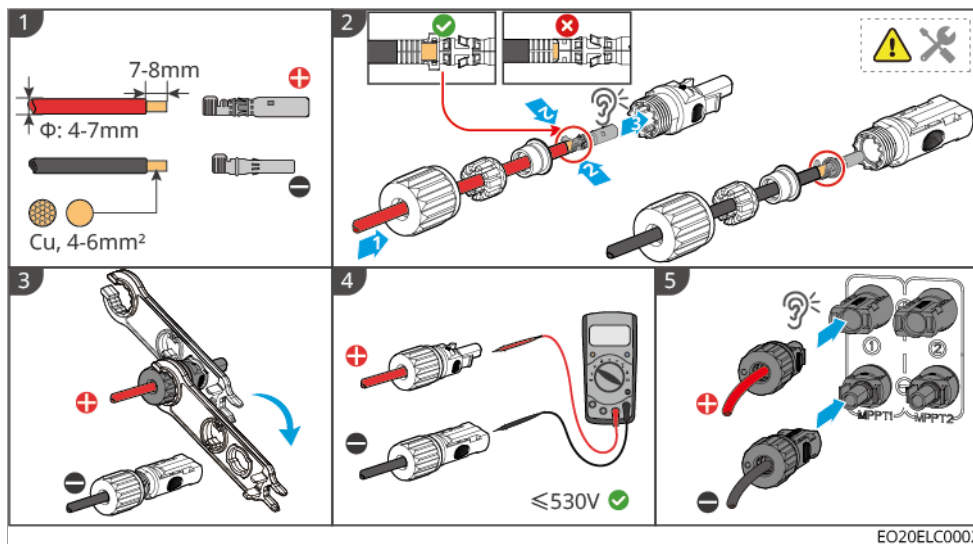

To disassemble the PV terminal, please refer to the following steps:

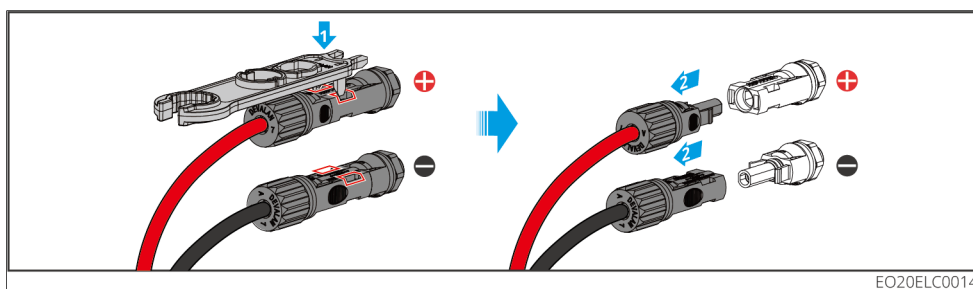

5.7 Connecting Battery Cables

Danger

- In a single-unit system, do not connect the same battery bank to multiple inverters, as this may damage the inverters.
- Do not connect any load between the inverter and the battery.
- When connecting battery cables, use insulated tools to prevent accidental electric shock or battery short circuits.
- Ensure the battery open-circuit voltage is within the permissible range of the inverter.
- Whether to install a DC switch between the inverter and the battery should be selected based on local laws and regulations.

Battery System Wiring Diagram

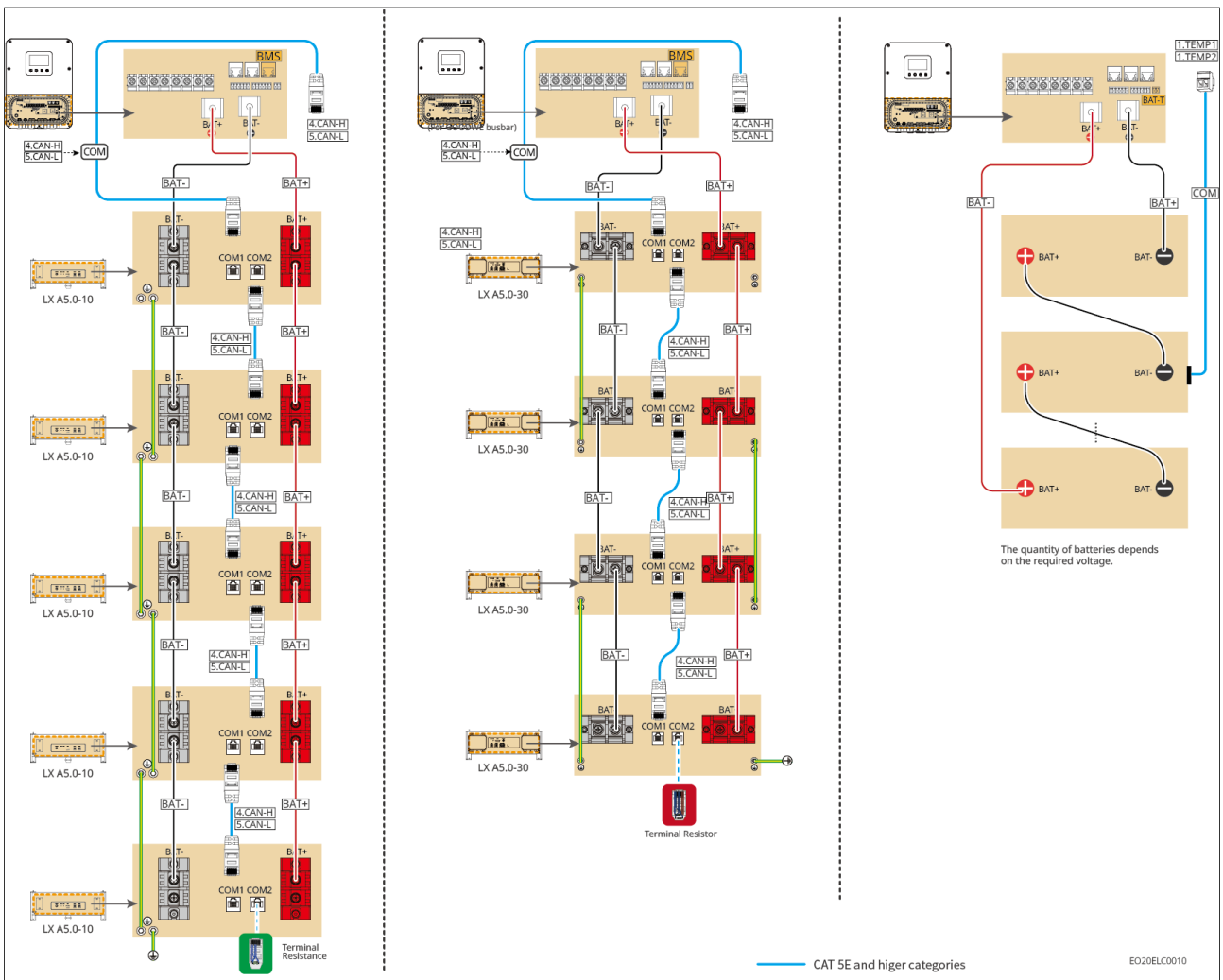

LXA5.0-30: Daisy-chain Connection Method

- The battery system supports up to 130A operating current, 8kW operating power, maximum connection of 1 inverter, and 30 batteries

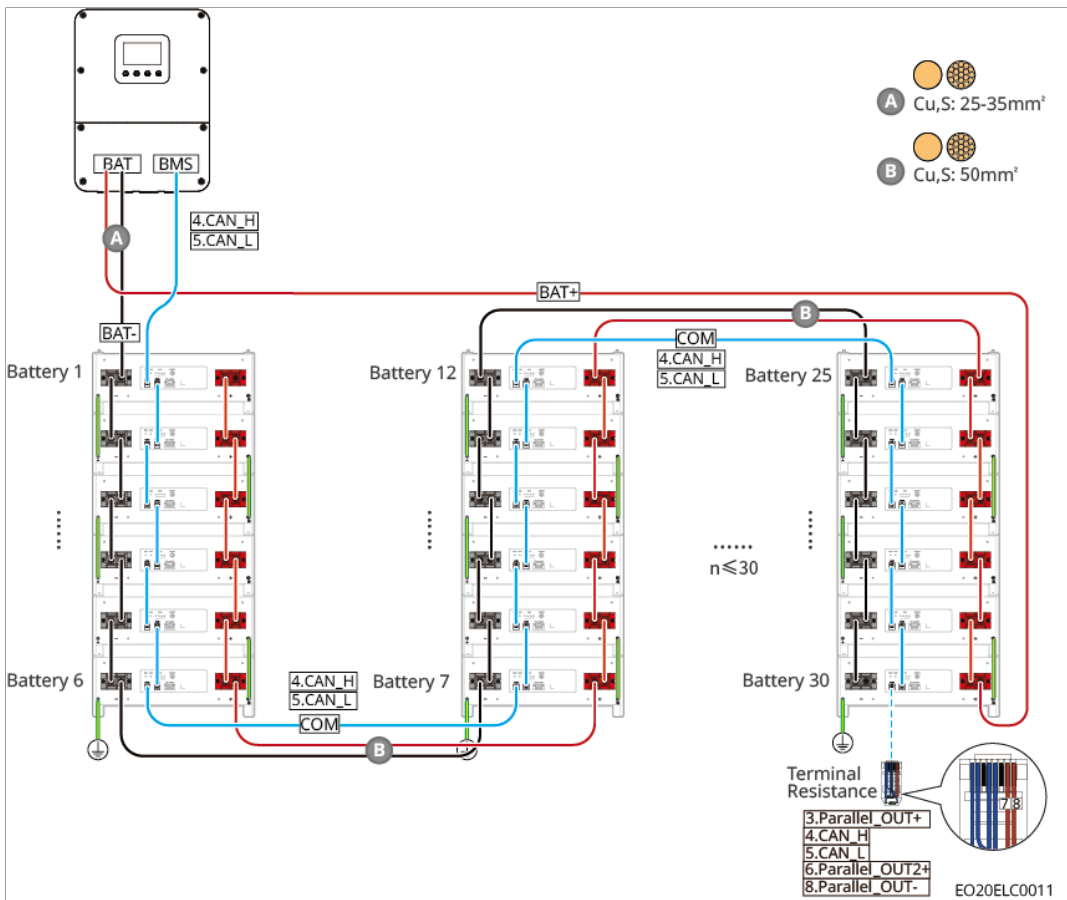

LX A5.0-10: Daisy-chain Connection Method

- The rated charge/discharge current for a single battery is 60A
- The battery system supports up to 120A operating current, 6kW operating power, maximum connection of 1 inverter, and 15 batteries

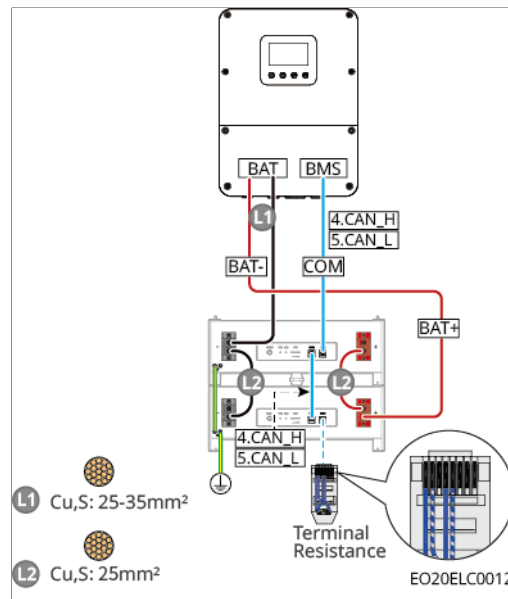

LX A5.0-30 Communication Port Definitions

PIN	COM1	COM2	Description
1	-	-	Reserved
2	-	-	
3	Parallel OUT+	Parallel OUT+	Parallel communication port
4	CAN_1H	CAN_1H	Connects to inverter communication or battery cluster parallel communication port
5	CAN_1L	CAN_1L	
6	Parallel OUT2+	Parallel OUT2+	Parallel interlock communication port
7	-	-	Reserved
8	Parallel OUT-	Parallel OUT-	Parallel communication port

LX A5.0-10 Communication Port Definitions

PIN	COM1	COM2	Description
1	-	-	Reserved
2	-	-	
3	Parallel OUT+	Parallel OUT+	Parallel communication port
4	CAN_1H	CAN_1H	Connect to inverter communication or battery parallel cluster communication port
5	CAN_1L	CAN_1L	

PIN	COM1	COM2	Description
6	-	-	Reserved
7	-	-	
8	Parallel OUT-	Parallel OUT-	Parallel communication port

5.7.1 Connecting Inverter and Battery Power Cables

Warning

- Use a multimeter to measure the positive and negative terminals of the DC cables to ensure correct polarity and no reverse connection; also ensure the voltage is within the allowable range.
- During wiring, ensure the battery cables fully match the "BAT+", "BAT-", and ground ports on the battery terminals. Incorrect cable connection will cause equipment damage.
- Ensure the wire strands are fully inserted into the terminal connection holes with no exposed parts.
- Ensure the cable connections are tight. Otherwise, loose connections may cause the terminal to overheat during equipment operation, leading to damage.
- Do not connect the same battery bank to multiple inverters, as this may cause inverter damage.

Overview of Inverter and Battery Power Cables

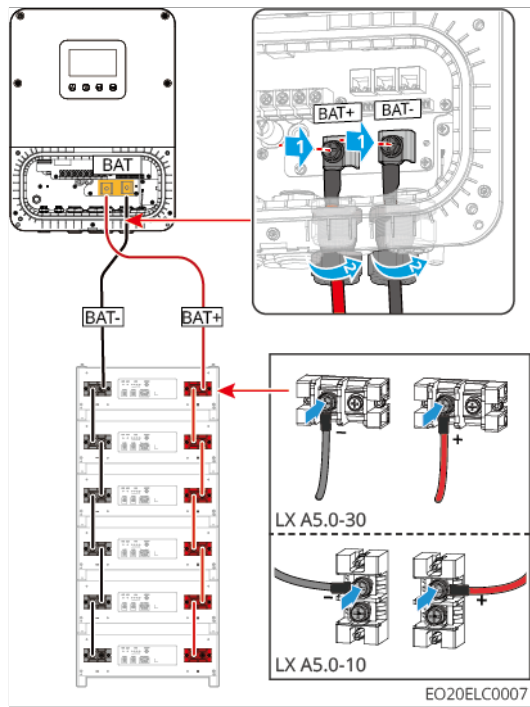

Inverter End Cable Assembly

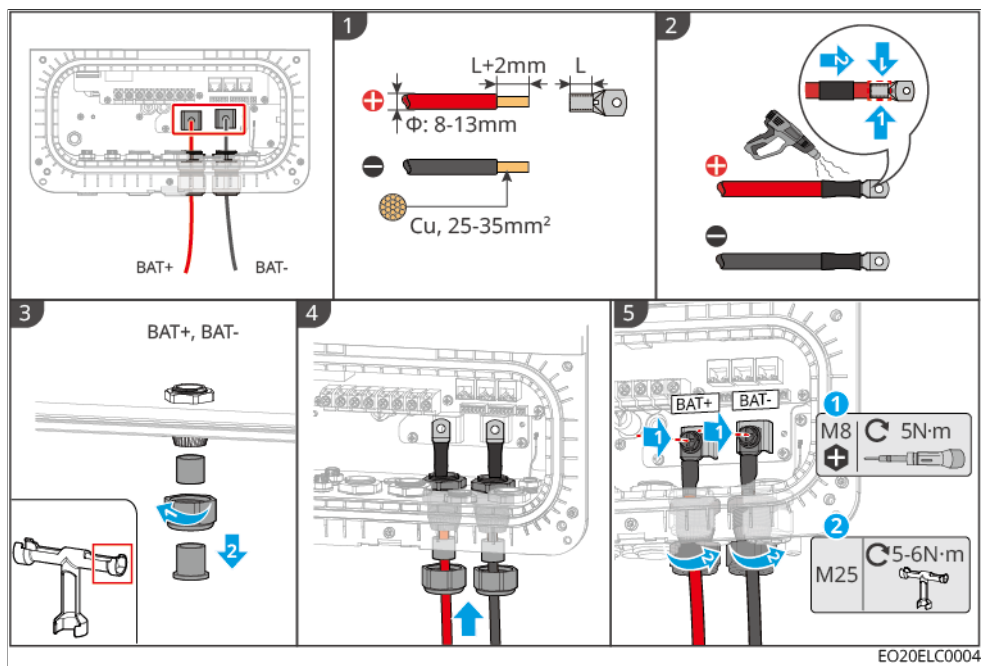

Battery End Cable Assembly Method (LX A5.0-10)

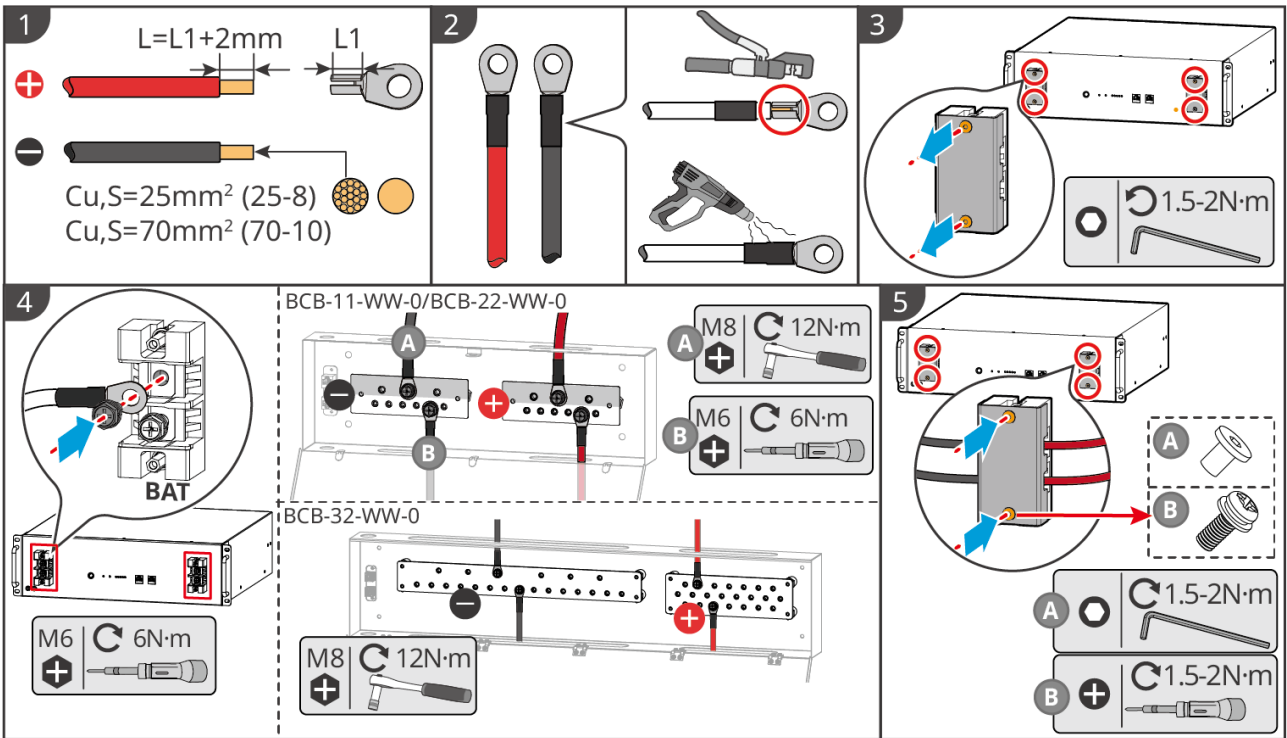

LXA10ELC0004

Battery End Cable Assembly Method (LX A5.0-30)

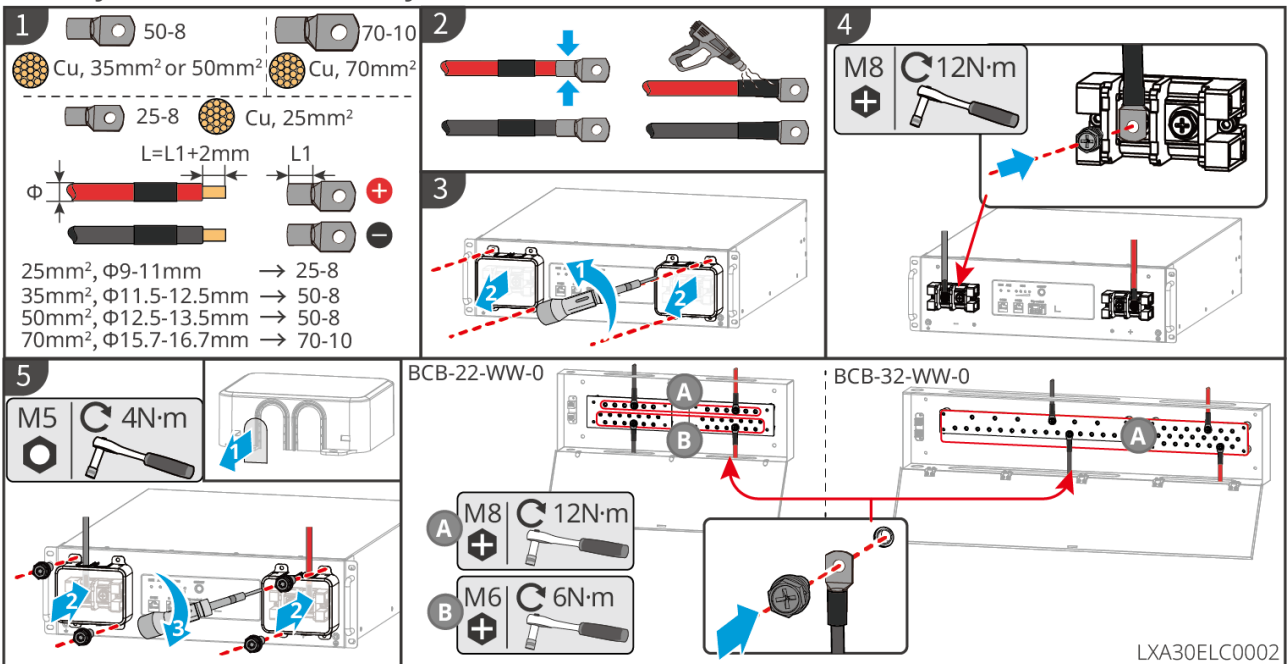

LXA30ELC0002

5.7.2 Connecting the Inverter and Battery Communication Cable

Note

A BMS battery communication cable is included in the package with the inverter. It is recommended to use the BMS battery communication cable provided with the package. If the communication cable provided with the package cannot meet the requirements, please prepare your own shielded network cable and shielded RJ45 connector.

Instructions for BMS communication connection between the inverter and battery:

Inverter Port	Connected to Battery Port	Port Definition	Description
BMS(CAN)	COM1	4: CAN_H 5: CAN_L	<ul style="list-style-type: none"> • Communication between the inverter and battery uses CAN protocol. • Connect the inverter's BMS port to the battery's COM1 port.

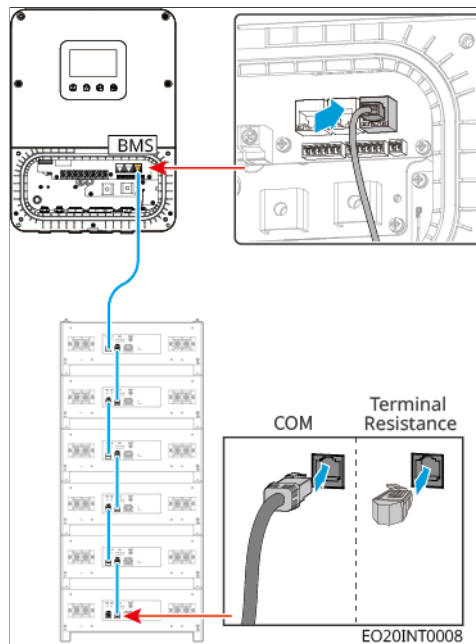

Note

- When connecting the lead-acid battery temperature sensor cable, it is recommended to connect it at a location with poor heat dissipation. For example: when lead-acid batteries are placed side by side, secure the sensor to the battery in the middle.
- To better protect the battery cells, the temperature sampling line must be installed, and it is recommended to place the battery in an environment with good heat dissipation.

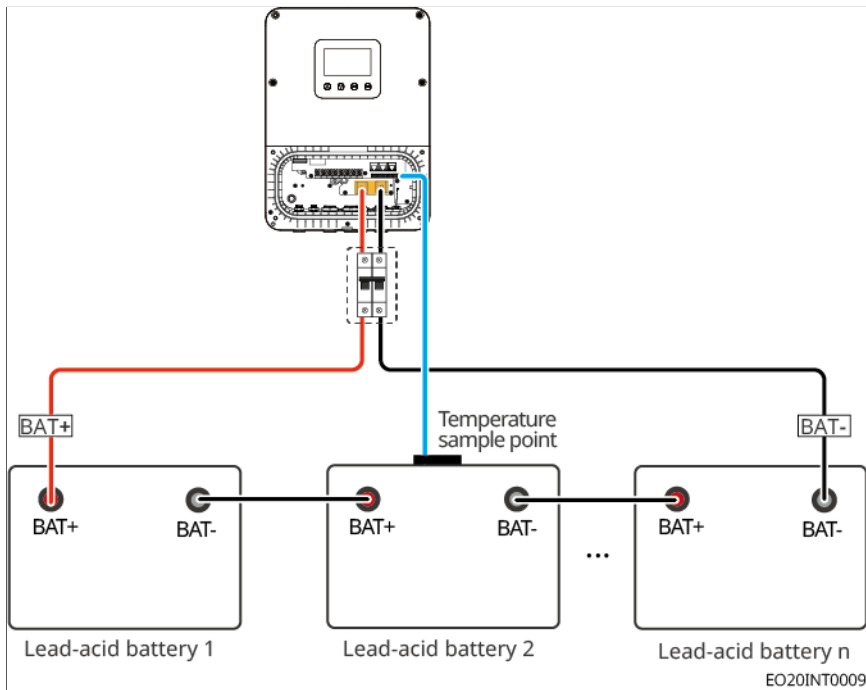

5.8 Connecting the AC Power Cable

 **Warning**

- The inverter is internally integrated with a Residual Current Monitoring Unit (RCMU) to prevent residual current from exceeding the specified value. When the inverter detects a leakage current greater than the permissible value, it will rapidly disconnect from the grid.
- During wiring, ensure the AC cables fully match the "BACK-UP", "GRID", "SMART", and grounding terminals on the AC terminal block. Incorrect cable connection will cause equipment damage.
- Ensure the wire cores are fully inserted into the terminal holes with no exposed parts.
- Ensure the insulation plate at the AC terminal block is securely fastened and not loose.
- Ensure all cable connections are tight. Otherwise, overheating of the terminals during operation may cause equipment damage.

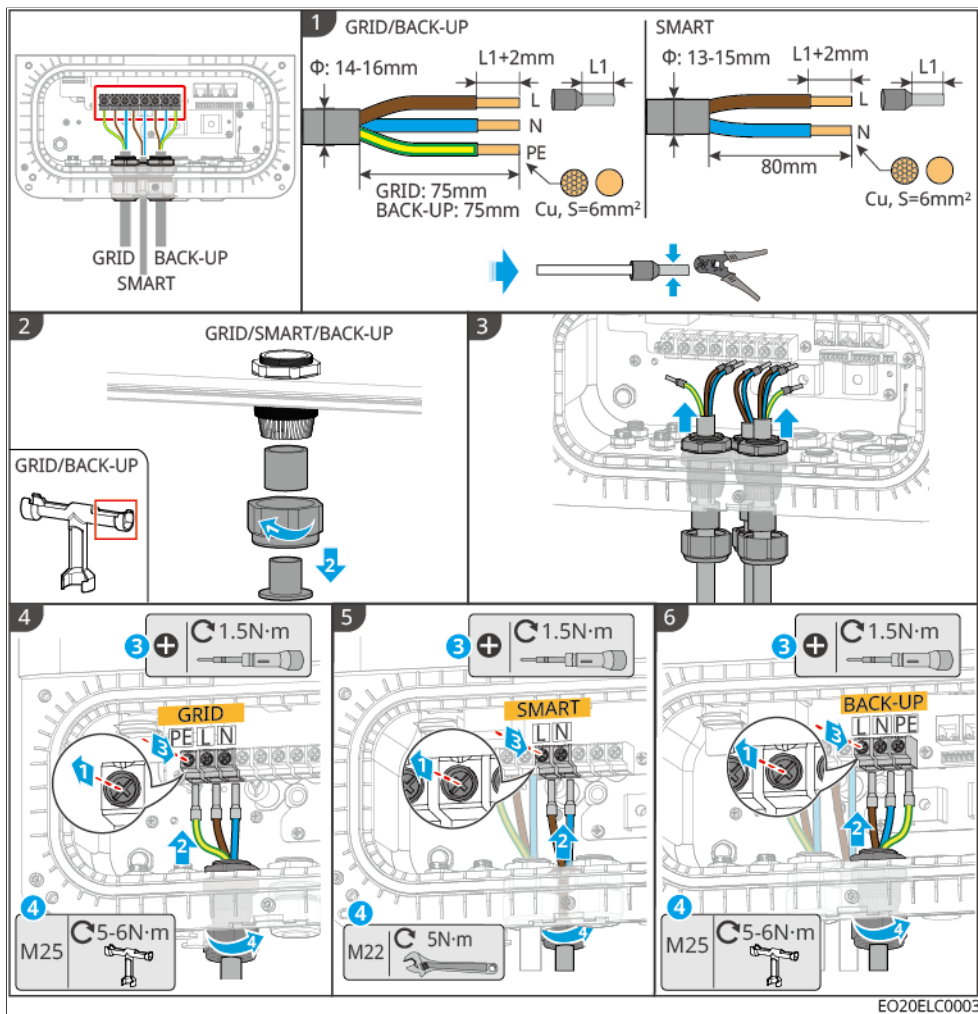

5.9 Connecting Meter Cables

Note

- Ensure the CT connection direction and phase sequence are correct; otherwise, it may lead to inaccurate monitoring data.
- Ensure all cables are connected correctly, securely fastened, and free from looseness. Improper wiring may cause poor contact or damage to the meter.
- In areas with lightning hazard, if the meter cable length exceeds 10m and the cables are not routed using grounded metal conduits, it is recommended to install external lightning protection devices.

Note

- The outer diameter of the AC power line must be smaller than the CT's inner diameter to ensure the AC power line can pass through the CT.
- To ensure the current detection accuracy of the CT, the CT cable length is recommended not to exceed 30m.
- Do not use network cables as CT cables, as excessive current may damage the meter.
- The CTs provided by the equipment manufacturer may vary slightly in size and appearance depending on the model, but the installation and wiring methods are the same.

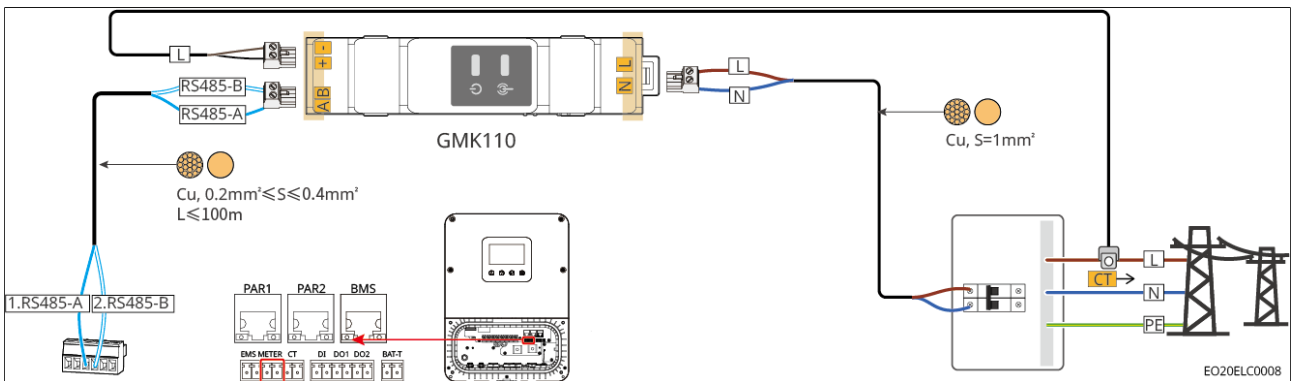

Wiring Steps

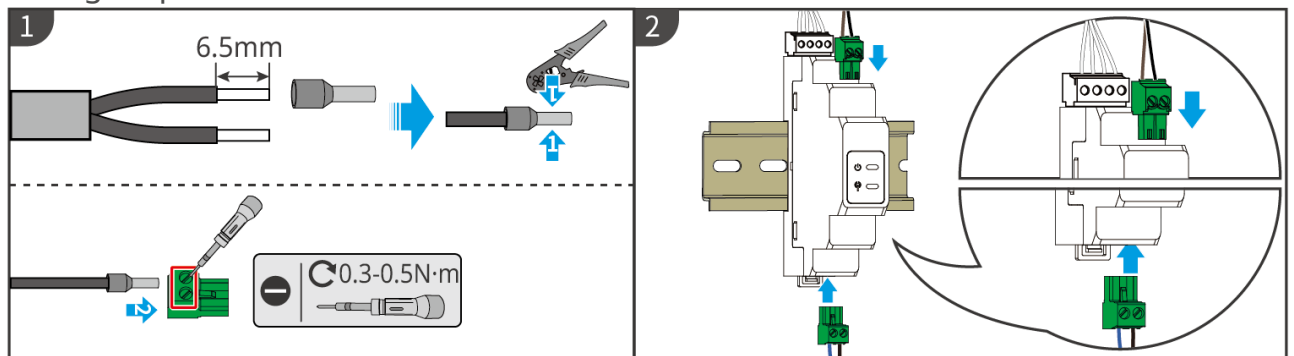

► GMK110: CT x 1; GMK110D: CT x 2

GMK10ELC0002

5.10 Connect Inverter Communication Cable

Note

- The inverter communication function is optional; please select according to the actual usage scenario.
- The inverter supports connecting to a mobile phone or WEB interface via Bluetooth or WiFi communication methods to set device-related parameters, view device operation information and error messages, and stay informed about the system status.
- If you need to use the remote shutdown function, please enable it in the SEMS+ App after wiring is completed.
- Do not enable this function in the SEMS+ App when the inverter is not connected to a remote shutdown device, otherwise the inverter will be unable to operate in grid-connected mode.

Communication Function Description

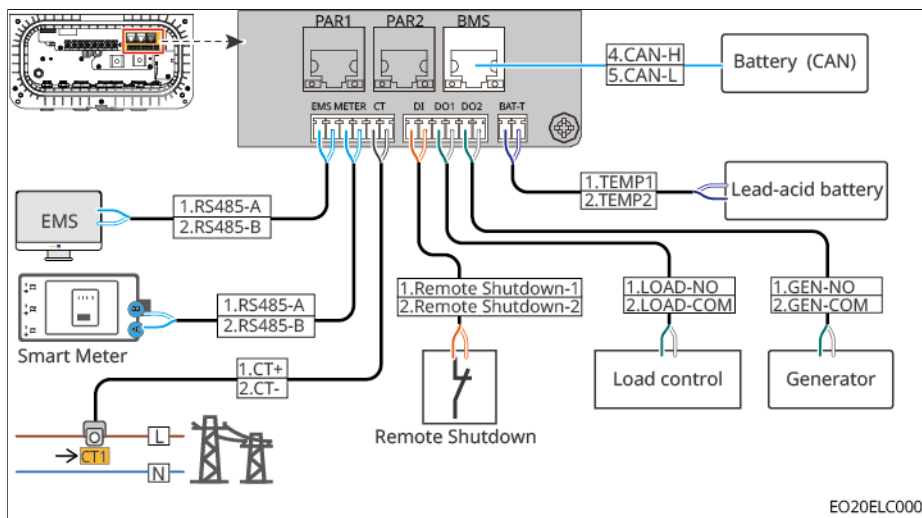

Port (Silkscreen)	Function	Description
PAR1&PAR2	(Reserved) Parallel Communication Port	-

Port (Silkscreen)	Function	Description
BMS	Battery BMS Communication	When connecting lithium-ion batteries, used to connect the BMS communication cable of the battery system, supports communication using CAN signals.
EMS	EMS Communication Port	When used to connect third-party EMS devices, supports RS485 communication method.
Meter	Meter Communication	Supports connecting to an external smart meter using RS485 communication.
CT	CT Connection Port	Connect the CT communication cable.
DI	Remote Shutdown	<ul style="list-style-type: none"> Remote Shutdown Function: After the emergency switch sends a shutdown signal, the AC side of the inverter automatically disconnects, stopping grid connection. Requires an external emergency shutdown switch and control via the DI port: The inverter starts when the DI port is closed; it stops when the DI port is open.
DO1	Load Control	<ul style="list-style-type: none"> Supports connection to dry contact signals for functions like load control. DO contact capacity is 24Vdc @1A, NO/COM normally open contacts. Supports SG Ready heat pump integration, controlling the heat pump via dry contact signals. Supported operating modes: <ul style="list-style-type: none"> Operating Mode 2 (Signal: 0:0): Energy-saving mode. In this mode, the heat pump operates in energy-saving mode. Operating Mode 3 (Signal: 0:1): Start recommendation. In this mode, the heat pump increases hot water reserve to store heat while maintaining current operation.

Port (Silkscreen)	Function	Description
DO2	Generator Start/Stop Control Port	Supports connection to generator control signals. DO contact capacity is 24Vdc @1A, NO/COM normally open contacts.
BAT-T	Lead-Acid Temperature Port	Used to connect the temperature sensor cable for lead-acid battery temperature measurement; please contact the distributor for purchase if needed.

Method for Connecting Communication Cable

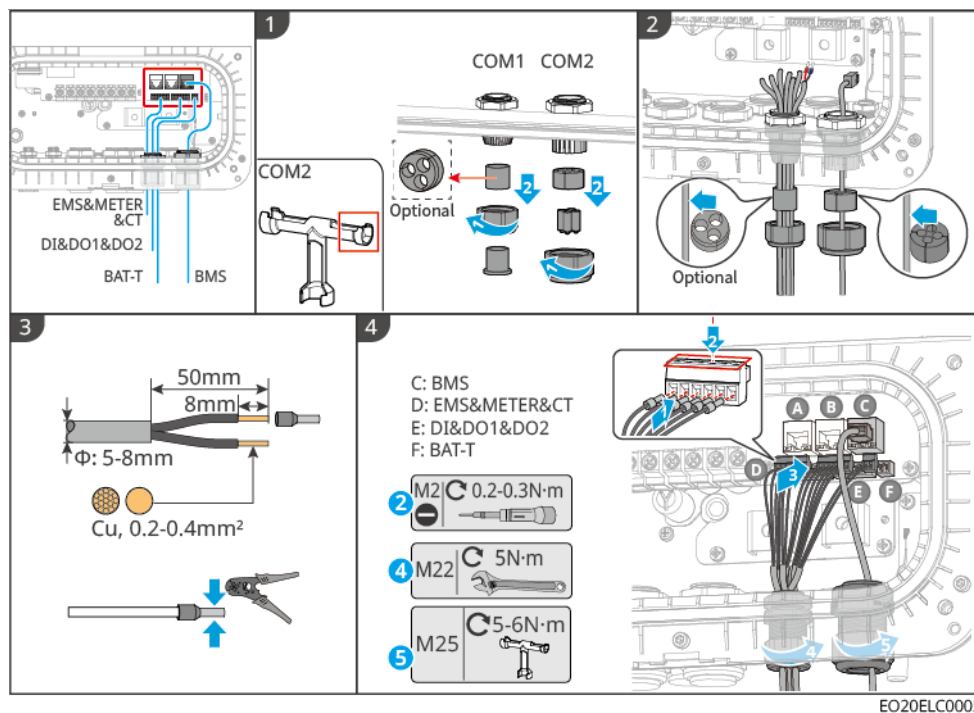

5.11 Installing the Inverter Chassis Lower Cover

Note

After completing the electrical wiring, the correctness and secure fastening of the connections must be checked. Thoroughly clean any debris left inside the wiring cavity, then install and securely fasten the lower enclosure cover to ensure waterproofing.

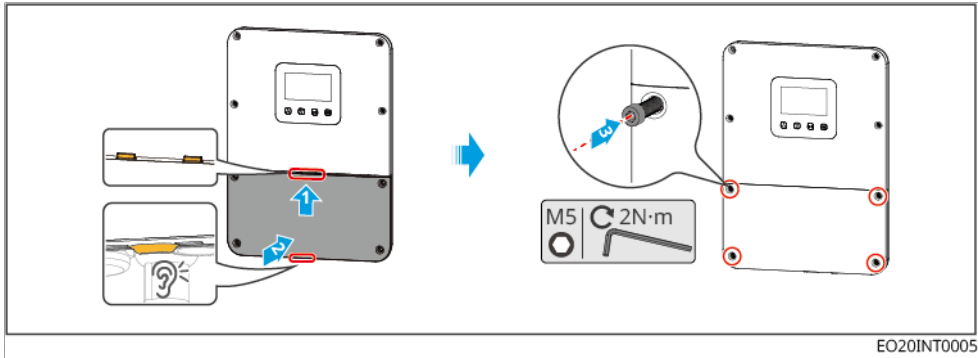

5.12 Installing the Battery Cover

5.12.1 LX A5.0-10

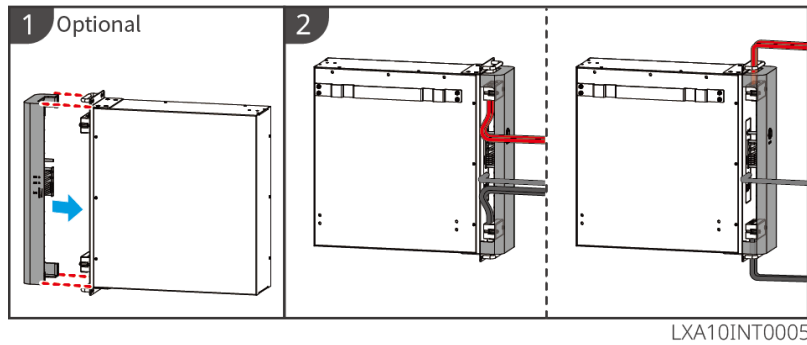

5.12.2 LX A5.0-30

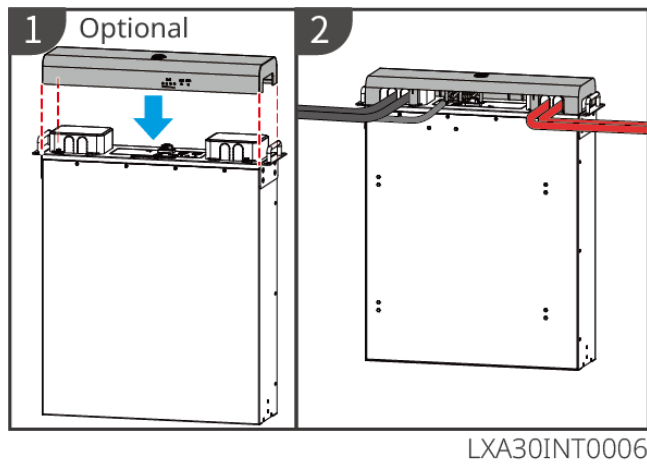

6 System Trial Run

6.1 System Pre-power-on Check

No.	Inspection Item
1	The equipment is securely installed. The installation location facilitates operation and maintenance, the installation space allows for ventilation and heat dissipation, and the installation environment is clean and tidy.
2	The protective ground wire, DC cable, AC cable, communication cable, and terminal resistor are correctly and securely connected.
3	Cable bundling meets routing requirements, is reasonably distributed, and shows no damage.
4	For unused cable entry holes and ports, ensure they are reliably connected and sealed using the terminals provided with the accessories.
5	Ensure that used cable entry holes have been sealed.
6	The voltage and frequency at the inverter's grid connection point comply with the grid connection requirements.

6.2 System Power On

Warning

- Battery black start usage scenarios:
 - When it is necessary to activate the inverter using the battery.
 - When battery charge/discharge management is required without an inverter present.
- After the battery system is started, ensure that communication between the inverter and the battery system is normal within 15 minutes. If normal communication cannot be established, the battery system switch will automatically disconnect, powering off the battery system.
- When multiple battery units are connected in parallel within the system, starting any one battery unit will start all batteries.

Power On Procedure

1. Close the switch between the inverter and the battery. (Select according to local regulations.)
2. Close the battery system switch.
3. Close the circuit breaker between the PV components and the inverter.
4. Close the grid-side circuit breaker.
5. Close the BACK-UP circuit breaker.
6. Close the generator/heavy load switch.

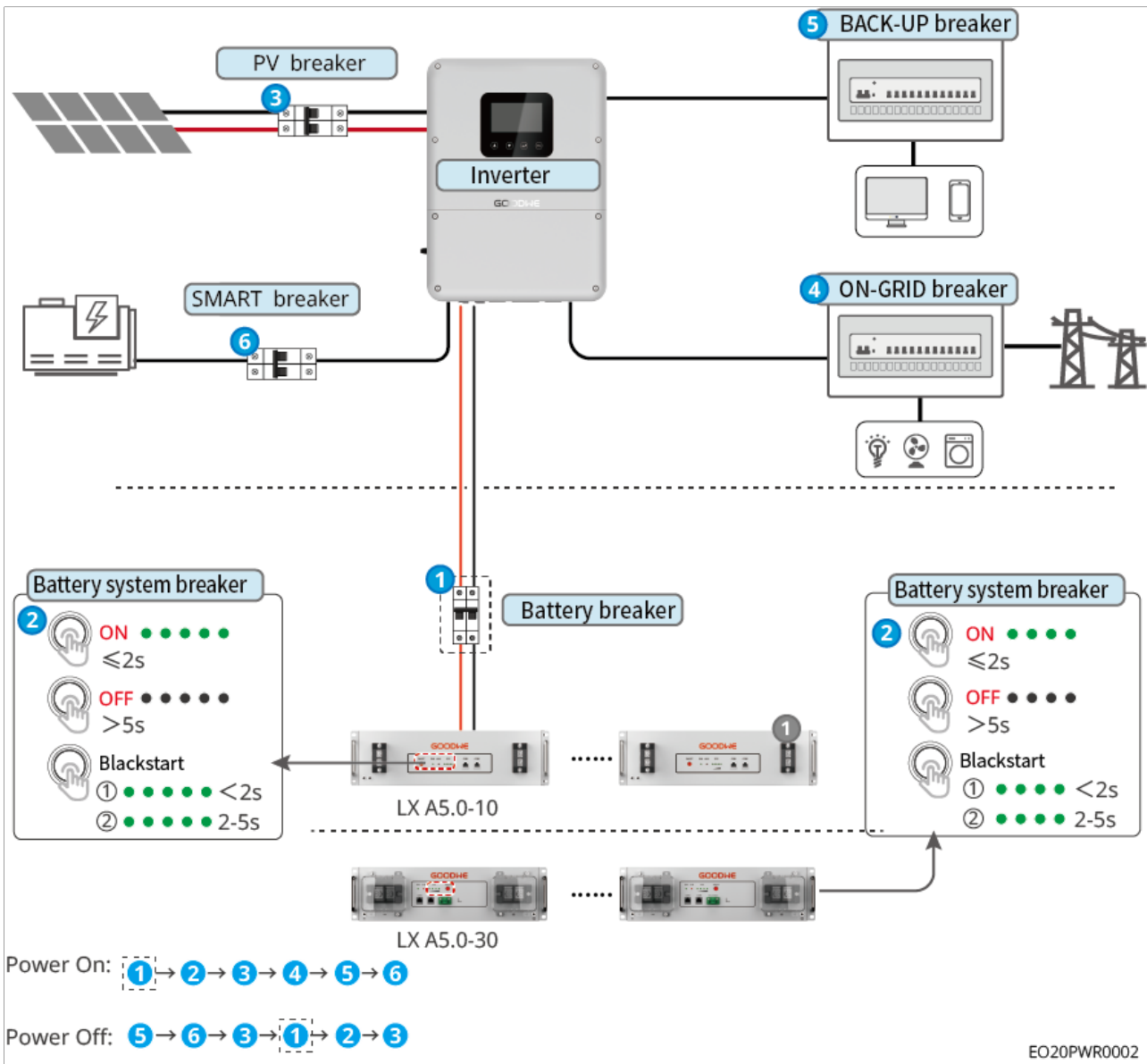







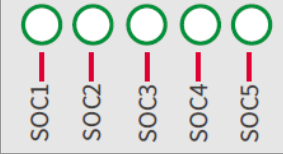

6.3 Indicator Light Introduction

6.3.1 Battery Indicator Light

6.3.1.1 LX A5.0-10

Normal State







<p>SOC Indicator</p> 	<p>RUN Light</p> 	<p>Battery System Status</p>
<p>The SOC indicator shows the battery system's power level.</p> <p>  SOC<5%  5%≤SOC<25%  25%≤SOC<50%  50%≤SOC<75%  75%≤SOC<95%  95%≤SOC≤100% </p>	<p>Green, blinking once per second</p>	<p>Battery system is in standby mode</p>
	<p>Green, blinking twice per second</p>	<p>Battery system is idle</p>
	<p>Green, solid on</p>	<p>Battery system is charging</p>
<p>The highest SOC indicator blinks once per second</p> <ul style="list-style-type: none"> • When 5% ≤ SOC < 25%, SOC1 blinks • When 25% ≤ SOC < 50%, SOC2 blinks • When 50% ≤ SOC < 75%, SOC3 blinks • When 75% ≤ SOC < 95%, SOC4 blinks • When 95% ≤ SOC ≤ 100%, SOC5 blinks 	<p>Green, solid on</p>	<p>Battery system is discharging</p>

Abnormal State

<p>ALM Indicator Light</p> 	<p>Battery System Status</p>	<p>Description</p>
<p>Red flashing once per second</p>	<p>Battery system alarm triggered</p>	<p>After a battery system alarm is triggered, the system will perform a self-check. Wait for the self-check to complete; the battery system will then enter normal operation status or fault status.</p>



ALM Indicator Light 	Battery System Status	Description
Red steady light	Battery system fault occurred	Determine the fault type based on the display pattern of the SOC indicator light, and handle it according to the methods recommended in the fault handling section.

6.3.1.2 LX A5.0-30 Indicator Light

Indicator		System Status
	No SOC indicator shows green	SOC=0%
	The first SOC indicator shows green	$0% < \text{SOC} \leq 25\%$
	The second SOC indicator shows green	$25% < \text{SOC} \leq 50\%$
	The third SOC indicator shows green	$50% < \text{SOC} \leq 75\%$
	The fourth SOC indicator shows green	$75% < \text{SOC} \leq 100\%$
 RUN Indicator	Solid green	The battery system is operating normally.
	Green blinking at 1 time/s	The battery system is in standby mode.
	Green blinking at 3 times/s	PCS communication lost.
	Slow blinking	After an alarm occurs, the battery system performs self-check. Wait for the self-check to complete, then it will switch to normal operation or fault status.

Indicator		System Status
 ALM Indicator	Solid red	Determine the fault type based on the display pattern of the SOC indicators, and handle it using the methods recommended in the fault handling section.

6.3.2 Smart Meter Indicator Light GMK110

Type	Status	Description
Power Light 	Steady on	The meter is powered on
	Off	The meter is powered off
Communication Light 	Blinking	The meter communication is normal
	Off	The meter communication is abnormal or not communicating

7 System Debugging

7.1 Introduction to Debugging Methods

Users can configure parameters via the SEMS+ APP, or set parameters through the LCD screen.

7.2 Configuration via LCD

7.2.1 LCD Introduction

Via the LCD screen, users can:

1. View device operation data, software version, alarm information, etc.
2. Set parameters, safety regulation regions, etc.

LCD Interface Introduction

The LCD supports both touch and button operations.

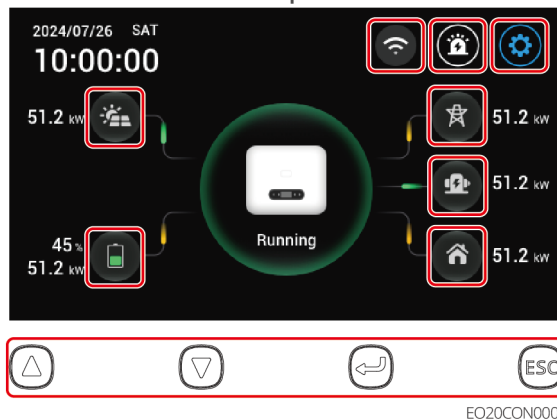



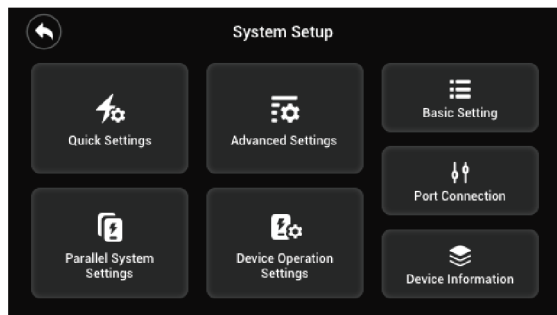



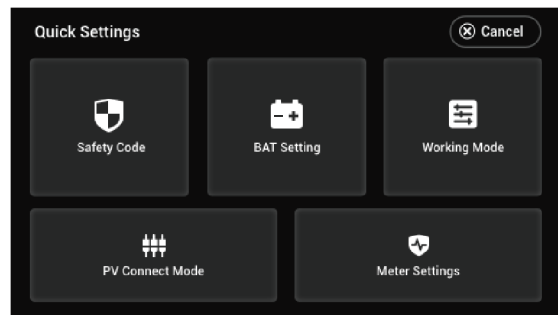







EO20CON001



EO20CON002



EO20CON003

Name/Icon	Description
	Up
	Down
	Confirm
	<ul style="list-style-type: none"> • Short press: Exit page • Press and hold  and  simultaneously for 5s: Restart device
	Used to view PV current, voltage, power generation, and other information
	Used to view battery model, status, and other information
	Used to view inverter alarm and fault information
	Press and hold for 3s to enter the inverter's settings interface
	Used to view grid status information
	Used to view generator status
	Used to view inverter load information
	Return to main interface
Cancel	Return to previous menu
Next	Go to next settings page
Back	Return to previous settings page

LCD Settings Interface Structure

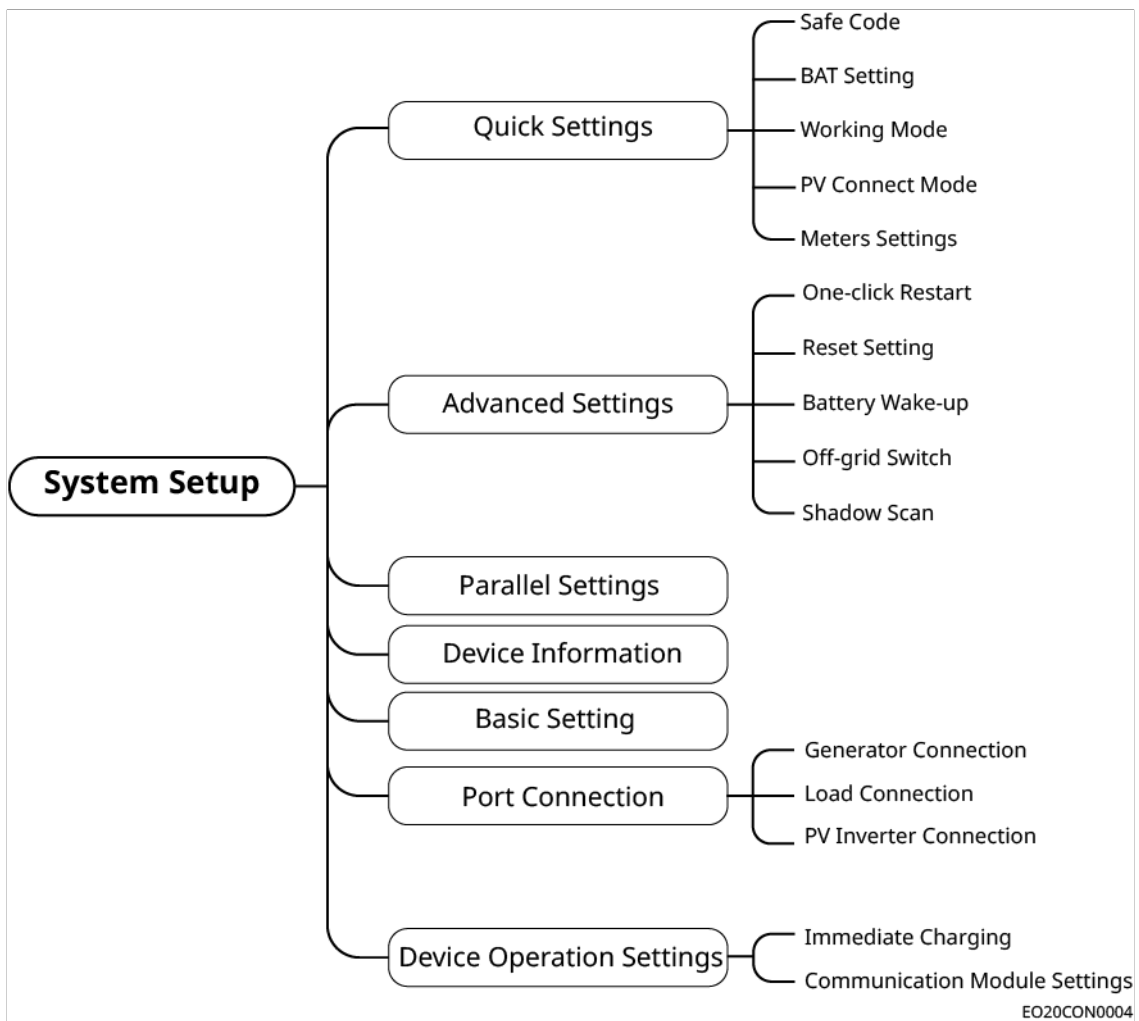

7.2.2 Quick Settings

Setting Safety Standards

1. From the main interface, click  > Quick Settings > Safe Code to enter the parameter setting interface.
2. Please select the corresponding safety standard code based on the country or region where the device is located.
3. After completing the settings, click Confirm. The parameter setting is successful when the interface prompts Confirm OK.

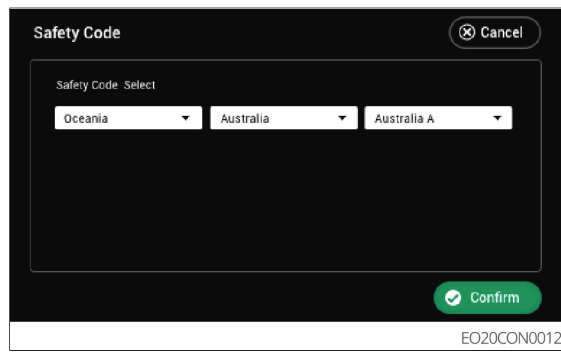

Setting Battery Parameters

1. From the main interface, click  > Quick Settings > BAT Setting to enter the parameter setting interface.
2. Please configure the parameters according to the actual situation.
3. After completing the settings, click Confirm. The parameter setting is successful when the interface prompts Confirm OK.

Note

Please ensure to click Confirm on each page to make the parameters take effect; otherwise, the system will run with default parameters.

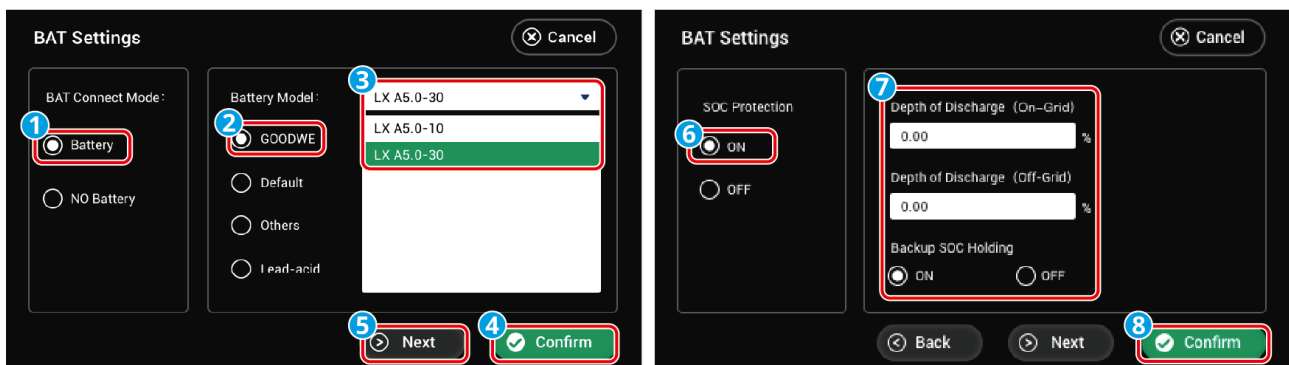

EO20CON0013

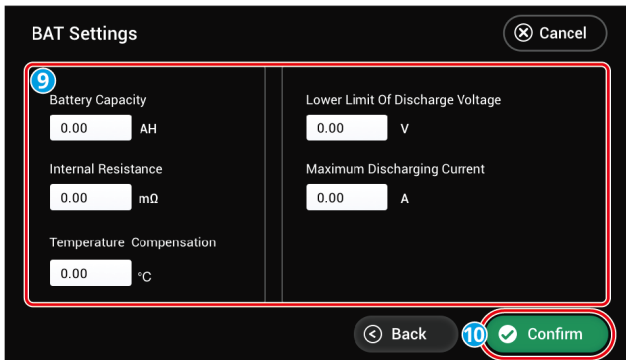
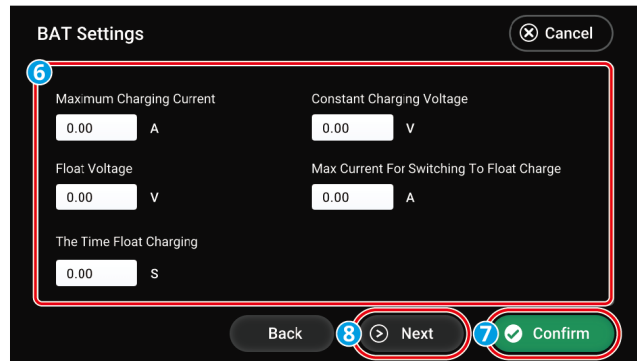
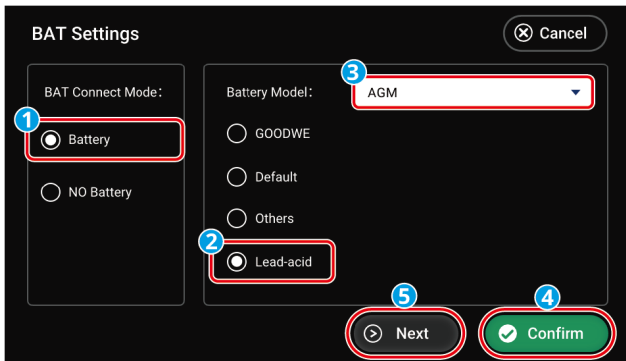

ESU10CON0011

Basic Parameter Settings

BAT Connection Mode	Type	Description
Battery	GOODWE	If the system is connected to a GOODWE brand lithium battery, select GOODWE and choose the correct model.
	Default	If the third-party lithium battery model connected to the system is not listed here, please select according to the actual situation: <ul style="list-style-type: none"> Lithium 50Ah Lithium 100Ah
	Others	If the third-party lithium battery model connected to the system is listed here, please select the correct model according to the actual situation.

BAT Connection Mode	Type	Description
	Lead acid	If the system is connected to a lead-acid battery, select Lead acid, and choose the correct lead-acid type. Currently supported types are GEL, AGM, Flooded.
NO Battery	No battery is connected to the system.	
BAT Setting	Set according to the actual battery connected in the system.	

Lithium Battery Parameter Settings

Parameter Name	Description
SOC Protection	Enable or disable the SOC protection function.
Depth Of Discharge (On-Grid)	The maximum discharge depth protection point for the battery when the inverter is operating in grid-tied mode.
Depth Of Discharge (Off-Grid)	The maximum discharge depth protection point for the battery when the inverter is operating in off-grid mode.
Backup SOC Holding	To ensure sufficient battery SOC for normal system operation during off-grid periods, the battery will be charged via the grid or PV to the set SOC protection value when the system is operating in grid-tied mode.

Lead-acid Battery Parameter Settings

Parameter Name	Description
Maximum Charging Current	Battery charging defaults to constant charging mode; The maximum charging voltage and maximum charging current in this mode must be set; please set according to the battery technical specifications.
Constant Charging Voltage	
Float Voltage	When the battery charging current is less than Maximum Current For Switch To Float Charge and this condition persists for The Time Float Charging, the battery charging status switches from constant charging mode to float charging mode. Float Voltage is the maximum charging voltage of the battery in float charging mode. Please set according to the battery technical specifications.
The Time Float Charging	
Maximum Current For Switch To Float Charge	

Parameter Name	Description
Battery Capacity	Set the battery capacity according to the parameters of the actually connected battery.
Internal Resistance	The resistance inherent within the battery. Please set according to the battery technical specifications.
Temperature Compensation	By default, when the temperature exceeds 25°C, for every 1°C increase, the upper limit of the charging voltage decreases by 3mV. Please set according to the actual battery technical specifications.
Lower Limit Of Discharge Voltage	Please set according to the battery technical specifications.
Maximum Discharging Current	Please set according to the battery technical specifications. The larger the discharge current, the shorter the battery operating time.

Setting Working Mode

1. From the main interface, click  > Quick Settings > Working Mode to enter the parameter setting interface.
2. Please configure the parameters according to the actual situation.
3. After completing the settings, click Confirm. The parameter setting is successful when the interface prompts Confirm OK.

Note

Please ensure to click Confirm on each page to make the parameters take effect; otherwise, the system will run with default parameters.

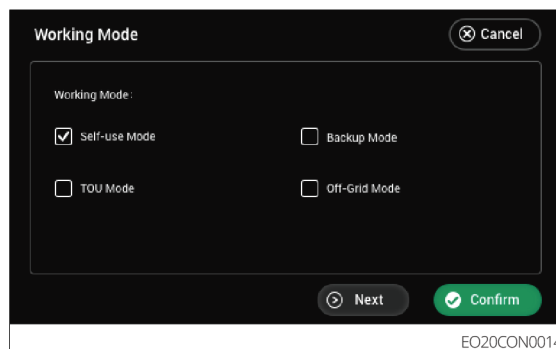

Parameter Name		Description
Self-use Mode		When the working mode is set to Self-use Mode, Back-up Mode, TOU Mode, and Off-Grid Mode can be enabled simultaneously. Please select according to the actual situation. The operational priority of the working modes is: Off-Grid Mode > Back-up Mode > TOU Mode > Self-use Mode.
Back-up Mode	Charging From Grid	Enable this function to allow the system to purchase electricity from the grid.
	Rated Power	The percentage of the power when purchasing electricity relative to the inverter's rated power.
TOU Mode	Time	Within the start and end time, the battery charges or discharges according to the set charge/discharge mode and rated power.
	Charge/Discharge	Set to charge or discharge based on actual requirements.
	Power (%)	The percentage of the power during charging or discharging relative to the inverter's rated power.
	Bat (%)	Charging stops when the battery level reaches the set SOC. To set the stop SOC for battery discharging, please refer to the chapter 9.2.2.2 Setting Battery Parameters and configure Depth of Discharge (On-Grid) and Depth of Discharge (Off-Grid) via the LCD screen.
Off-Grid Mode		Do not run the pure off-grid mode when the inverter is not connected to a battery system.

Setting PV Connection Mode

1. From the main interface, click  > Quick Settings > PV Connect Mode to enter the parameter setting interface.
2. Please configure the parameters according to the actual situation.
3. After completing the settings, click Confirm. The parameter setting is successful when the interface prompts Confirm OK.

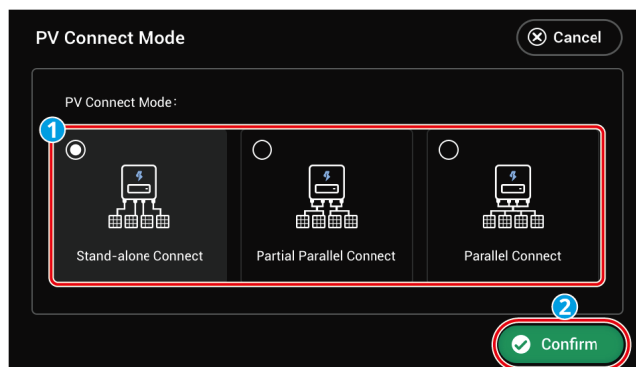

ESU10CON0015

Parameter Name	Description
Stand-alone Connect	Each PV string is connected one-to-one to the MPPT port on the inverter side.
Partial Parallel Connect	When one PV string is connected to multiple MPPT ports on the inverter side, other PV modules are simultaneously connected to other MPPT ports on the inverter side.
Parallel Connect	When external PV strings are connected to the PV input ports on the inverter side, one PV string is connected to multiple PV input ports.

Meter Settings

1. From the main interface, click > Quick Settings > Meter Settings to enter the parameter setting interface.
2. Click Start Test to begin detection. After detection is complete, determine the result based on the interface prompt.

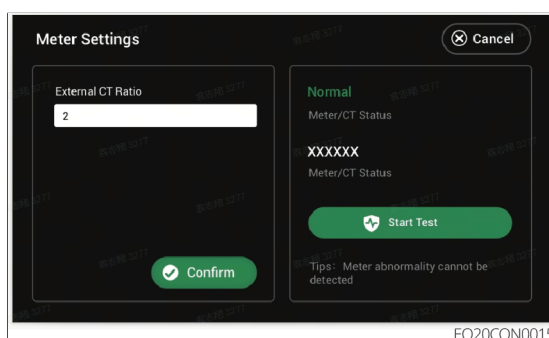

EO20CON0015

7.2.3 Set Advanced Parameters

1. From the main interface, click > Advanced Settings to enter the parameter

- setting interface. Enter the initial password: 1111.
- Please set the parameters according to the actual situation.
 - After setting is complete, click Confirm. The interface will prompt Confirm OK, indicating successful parameter setting.

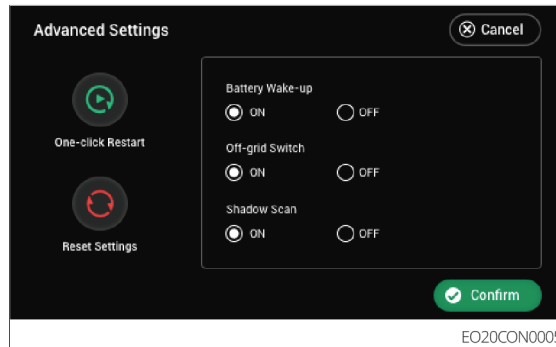

Parameter Name	Description
One-click Restart	Using this function allows for a quick restart of the inverter.
Reset Settings	Restores the inverter to factory settings.
Battery Wake-up	When enabled, this function can wake up the battery after it has shut down due to undervoltage protection. If there is a circuit breaker between the lithium battery and the inverter, ensure the circuit breaker is in the closed state. After enabling, the output voltage at the battery port is approximately 60V.
Off-grid Switch	In off-grid mode, the off-grid control switch controls the enabling and disabling of the inverter's off-grid function. This function is not effective in grid-tied mode. The switch is initially in the ON state, enabling the off-grid function. After the inverter is powered on, it activates the off-grid output function. In the off-grid state, turning the off-grid switch off and then on can clear the off-grid overload timer and restart off-grid output.
Shadow Scan	When photovoltaic panels are severely shaded, enabling the shadow scan function can optimize the inverter's power generation efficiency.

7.2.4 Set Immediate Charging

1. Through the main interface, click  > Device Operation Settings > Immediate Charging to enter the parameter setting interface.
2. Set parameters based on actual requirements.
3. After setting is complete, please click Confirm. After the interface prompts Confirm OK, the parameter setting is successful.

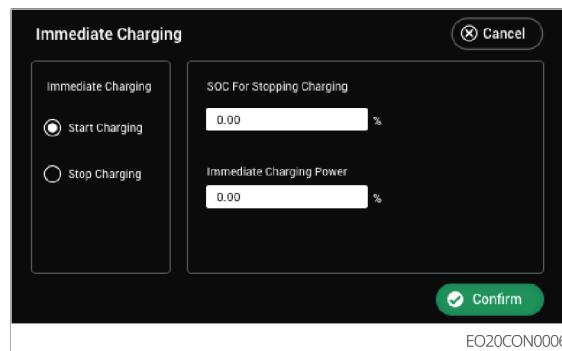

Parameter Name	Description
Immediate Charging	When enabled, the battery is charged immediately from the grid. Takes effect only once. Please enable or stop it as needed.
SOC For Stopping Charging	When Immediate Charging is enabled, battery charging will stop once the battery SOC reaches the charging cutoff SOC.
Immediate Charging Power	The charging power as a percentage of the inverter's rated power when Immediate Charging is enabled. For example, for a 10kW rated inverter, setting this to 60 results in a charging power of 6kW.

7.2.5 Setting the Basic Information

Setting Time

1. From the main interface, click  > Basic Settings to enter the parameter setting interface.
2. Please set the parameters according to the actual situation.
3. After setting is complete, click Confirm. When the interface prompts Confirm OK, the parameter setting is successful.

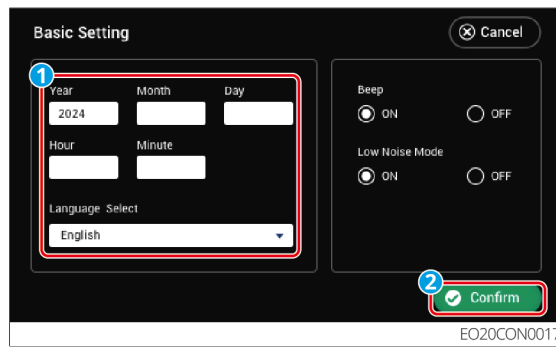

Setting the Buzzer

After enabling the buzzer, it will sound when the inverter has a serious fault.

1. From the main interface, click  > Basic Settings > Beep to enter the parameter setting interface.
2. Please set the parameters according to the actual situation.
3. After setting is complete, click Confirm. When the interface prompts Confirm OK, the parameter setting is successful.

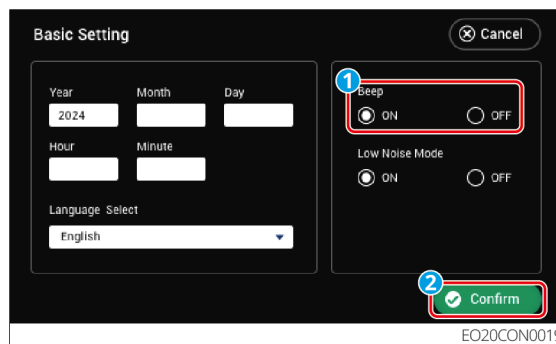

Setting Silent Mode

Conditions and effects of enabling silent mode:

- Prerequisite: Must be connected to a stable and reliable grid, otherwise this mode will not take effect.
- NOTICE: If the load is too high, the system may automatically purchase electricity from the grid to make up the shortfall, leading to increased electricity bills.
- Effect: During the activation of this mode, there may be some loss in photovoltaic power generation.

1. From the main interface, click  > Basic Settings > Low Noise Mode to enter the parameter setting interface.
2. Please set the parameters according to the actual situation.

3. After setting is complete, click Confirm. When the interface prompts Confirm OK, the parameter setting is successful.

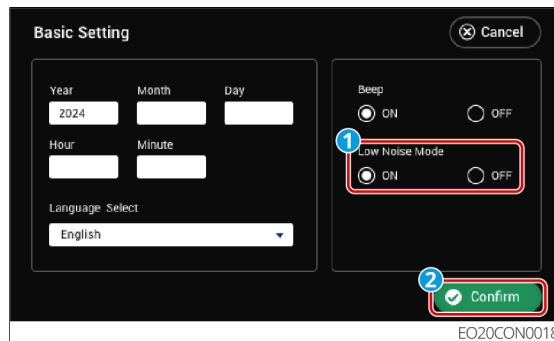

7.2.6 Port Connection Setup

Setting Port Connection for Generator

1. From the main interface, click  > Port Connection to enter the parameter settings interface.
2. Please set the parameters according to the actual situation.
3. After completing the settings, click Confirm. The parameter setup is successful when the interface prompts "Confirm OK".

Note

Please ensure to click Confirm on each page to make the parameters take effect; otherwise, the system will run with default parameters.

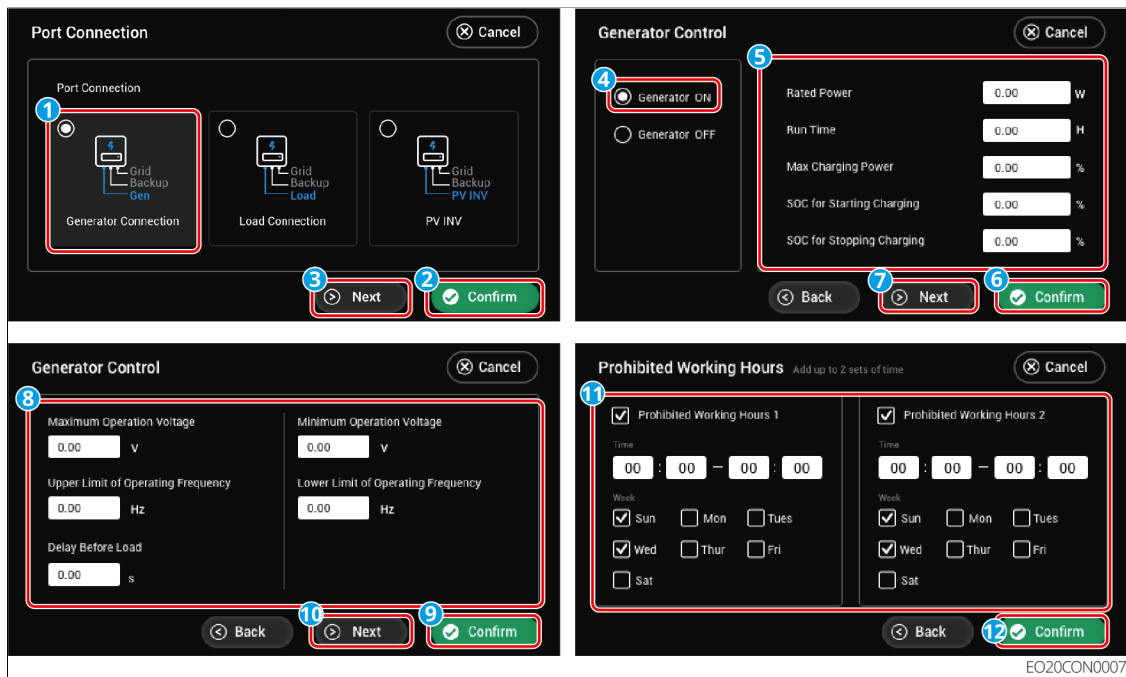

No.	Parameter Name	Description
1	Generator ON/OFF	Controls the start/stop of the generator. Applies only to generators supporting dry contact.
2	Rated Power	The rated power of the generator.
3	Run Time	The continuous operation time of the generator. The generator will automatically shut down after exceeding the set runtime. This function only takes effect for generators supporting dry contact connection.
4	Max Charging Power	Sets the maximum charging power for the generator when charging the battery.
5	SOC for Starting Charging	Sets the start SOC for the generator to charge the battery. When the battery's SOC falls below the set value, the generator will charge the battery.
6	SOC for Stopping Charging	Sets the SOC for the generator to stop charging the battery. When the battery's SOC reaches the set value, the generator will stop charging the battery.
7	Maximum Operation Voltage	Sets the upper limit of the generator's operating voltage.
8	Minimum Operation Voltage	Sets the lower limit of the generator's operating voltage.

No.	Parameter Name	Description
9	Upper Limit Of Operating Frequency	Sets the upper limit of the generator's operating frequency.
10	Lower Limit Of Operating Frequency	Sets the lower limit of the generator's operating frequency.
11	Delay Before Load	The no-load warm-up time for the generator before applying load.
12	Prohibited Working Hours	Please set the generator's prohibited working hours according to actual requirements.

Setting Port Connection for Load Control

1. From the main interface, click  > Port Connection to enter the parameter settings interface.
2. Please set the parameters according to the actual situation.
3. After completing the settings, click Confirm. The parameter setup is successful when the interface prompts "Confirm OK".

Note

Ensure you click Confirm on each page for the parameters to take effect; otherwise, the system will run with default parameters.

Dry Contact Mode

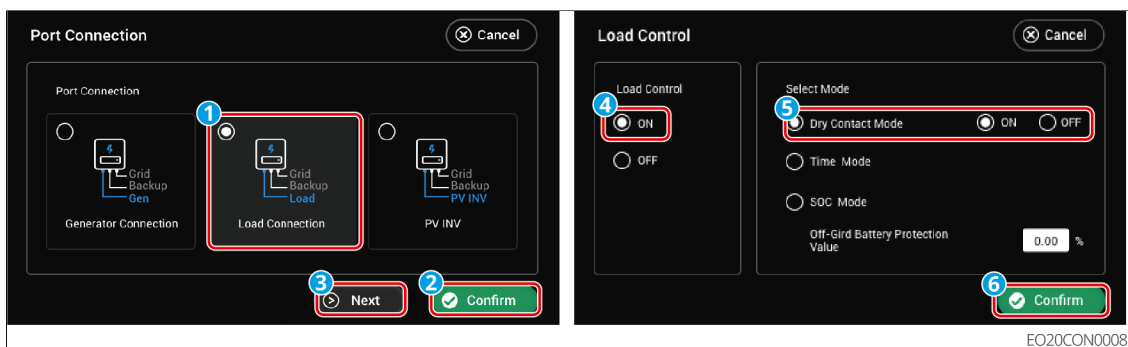

Time Mode



EO20CON0009

SOC Mode

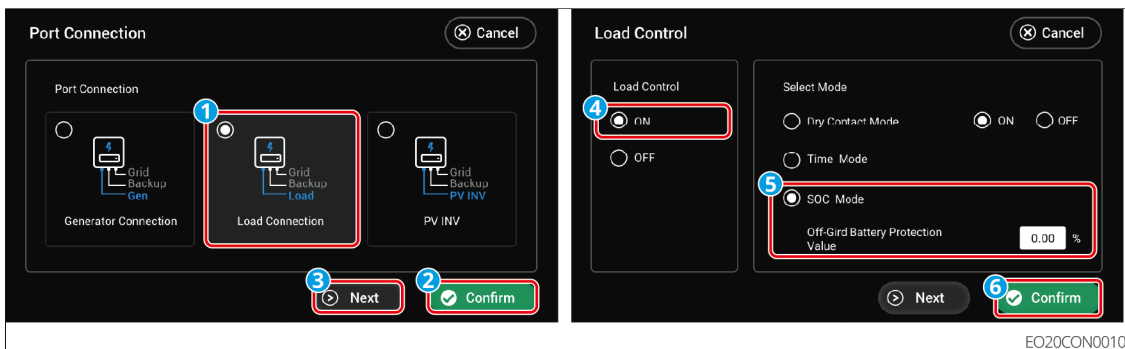

EO20CON0010

No.	Parameter Name	Description
1	Load Control ON/OFF	Set the load control function ON/OFF
2	Dry Contact Mode	ON: Start supplying power to the load when the switch status is selected as ON. OFF: Stop supplying power to the load when the switch status is set to OFF.
3	Time Mode	Within the set time period, the load will be automatically powered on or off. Standard mode or Intelligent mode can be selected.
4	Load Control 1	Set the time for the 1st load control group. Up to 4 groups can be set.

No.	Parameter Name	Description
5	Mode: Standard/Intelligent	Standard Mode: Will supply power to the load within the set time period. Intelligent Mode: Within the set time period, starts supplying power to the load when the surplus energy generated by PV exceeds the preset load rated power.
6	Load Consumption Time	The minimum runtime for the load after it is turned on, to avoid frequent switching due to energy fluctuations. Applicable only to Intelligent Mode.
7	Load Rated Power	When the surplus energy generated by PV exceeds this load rated power, starts supplying power to the load. Applicable only to Intelligent Mode.
8	SOC Mode	The inverter has built-in relay dry contact control ports. Whether to supply power to the load can be controlled via the relay.
9	Off-Grid Battery Protection Value	In Off-Grid mode, if overload at the BACK-UP end is detected or the battery SOC value is lower than the Off-Grid Battery Protection set value, power supply to the load connected to the relay port can be stopped. Please set the Off-Grid Battery Protection value according to actual needs.

7.2.7 Communication Settings

The inverter has built-in Bluetooth and WiFi signals. You can restart the communication signal, reset the communication configuration, and enable the Bluetooth signal.

1. From the main interface, click  > Quick Settings > Communication Module Settings to enter the parameter settings interface.
2. Set the parameters according to your actual needs.
3. After completing the settings, click Yes as prompted. The parameter setting is successful when the interface displays Confirm OK.

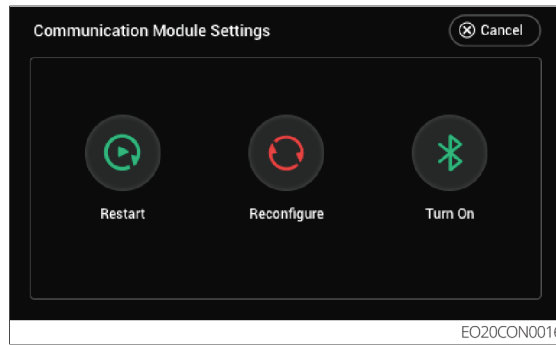

Serial Number	Parameter Name	Description
1	Restart	Restart the wireless signal.
2	Reconfigure	Restore communication to factory settings. To continue using the device, you will need to reconfigure the WiFi connection information.
3	Turn On	Turn on the Bluetooth signal. The Bluetooth signal is turned on by default from the factory. After connecting to the APP, please follow the prompts to choose whether to keep it on. If you choose no, you will need to turn it on again the next time you connect to the Bluetooth signal.

7.2.8 View Device Information

1. From the main interface, click  > Device Information to enter the parameter query screen.

Note

You can query the inverter serial number, DSP version, BMS version, LCD version, and ARM version.

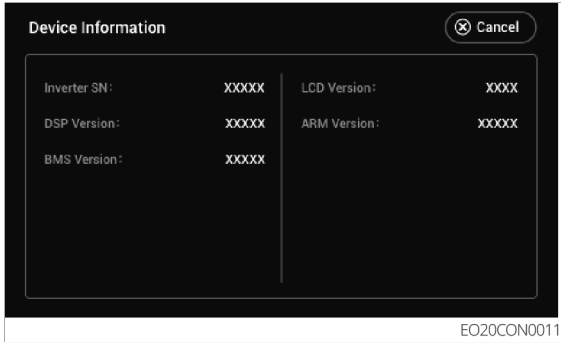

8 Power Station Monitoring

8.1 App Introduction

Note

- The interfaces shown in this manual are based on SEMS+ App V2.0.1. The interface may differ in subsequent versions.
- Different login roles may have access to different parameters and operational permissions.
- The parameters and functions displayed may vary depending on the device model and the safety standards of the country it belongs to.
- The manual content is for reference only. Please refer to the actual display in the App.
- If you need to modify power plant or device parameters, please carefully read this manual and the corresponding product manual before making changes to familiarize yourself with the product's functions and features. Incorrect grid parameter settings may prevent the inverter from connecting to the grid or cause it to not connect according to grid requirements, affecting the inverter's power generation.

This document introduces the common operations of the SEMS+ App.

SEMS+ App is a software used for remote power plant monitoring or local device debugging. Installers or owners can:

- Remotely monitor the power plant operation status and set operating parameters for the power plant and devices.
- Locally connect to devices to view their operation status and set device parameters.

8.1.1 Supporting Products

Supports monitoring and managing related devices of the GoodWe brand, such as inverters, smart meters, data collectors, charging piles, batteries, etc.

8.1.2 Download and Install SEMS+ App

Phone Requirements:

- Operating System: Android 7.0 or above, iOS 15.1 or above.
- Phone must support a web browser and connect to the Internet.
- Phone must support WLAN/Bluetooth functionality.

Download Methods:

Method 1:

Search for "SEMS+" in Google Play, App Store, Huawei, Honor, Xiaomi, OPPO, or vivo app stores to download and install.



Method 2:



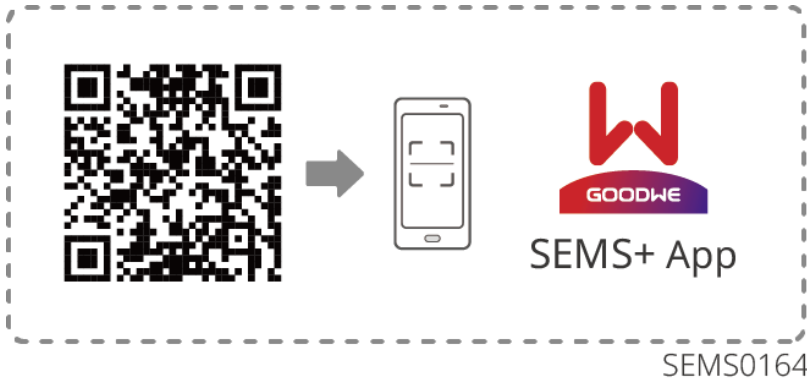



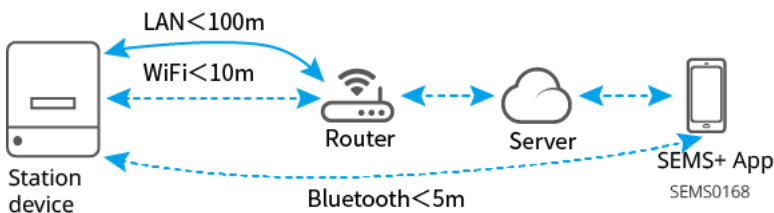









Scan the QR code below to download and install.



8.1.3 Connection Methods



8.1.4 Common Icon Descriptions

Icon	Description	Icon	Description
	Create power plants, add devices, etc.		Scan for nearby devices.
	More information.		Filter.
	Notifications.		Favorite or unfavorite.
	Save.		Edit.
	Delete.		Copy.
	Expand or collapse data display.		Device software version upgrade.
	Enlarge chart display.		Turn on or off.
	Sort. Click to sort in ascending or descending order.		Expand the plant list and switch plants.

8.1.5 Register Account

Steps

1. On the App home page, click "Register" to enter the account registration interface.
2. Select the server and account type according to your actual needs, then click "Next".
3. Enter the account information according to the actual situation and click "Confirm" to complete the registration.

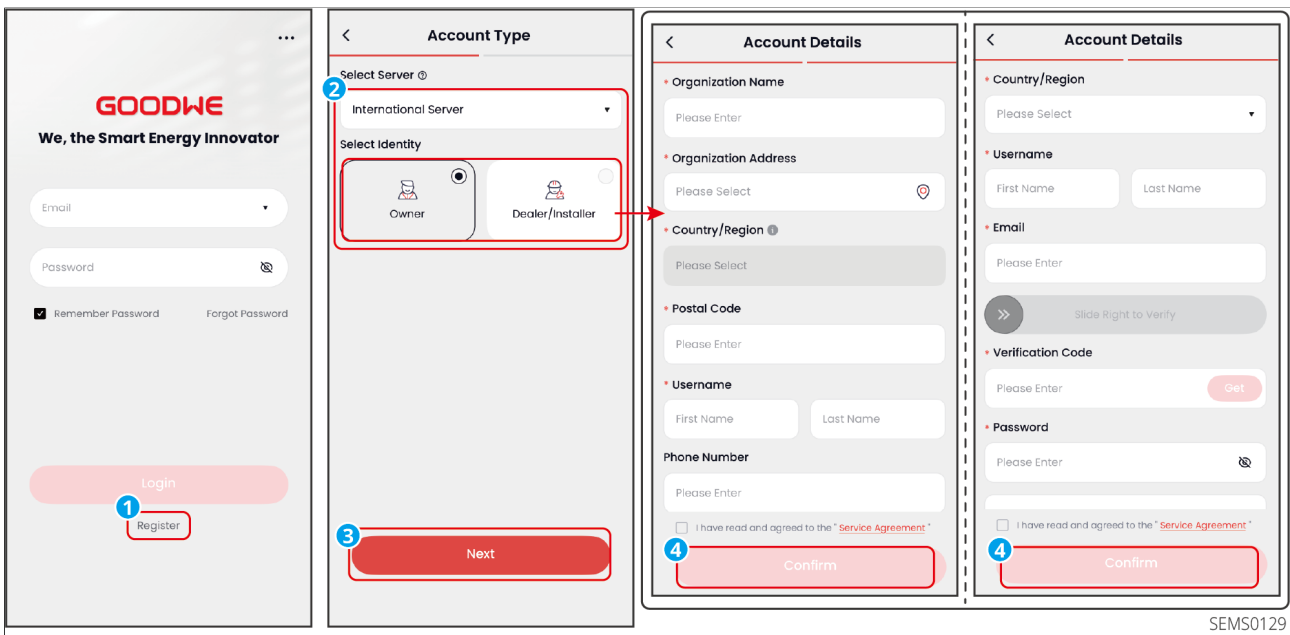

Figure1 Register Account

8.1.6 Login Account

Note

- Before logging into the App, please register an account or obtain the account and password from a dealer.
- After logging in, you can view or manage power station information. The specific interface may vary based on actual conditions. Depending on account type, region, power station type, etc., the displayed power station information may differ.

Operation Steps

1. Enter the account and password, and click 'Login'.

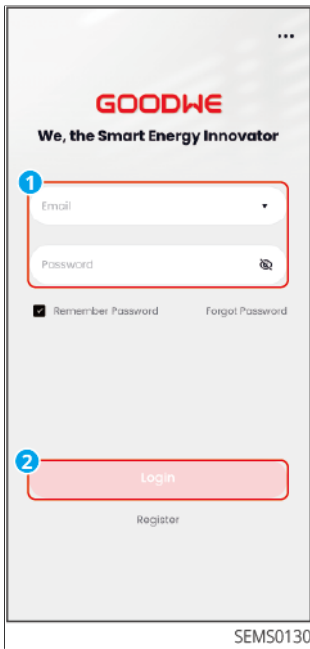

Figure2 Login Account

8.2 Remote Monitoring Power Station

Note

Depending on account type, region, station type, etc., the displayed station information may vary.

After logging into the App with your account and password, you can create power stations, add devices, monitor the operational status of power stations, view device operation information, and more.

8.2.1 Power Plant

8.2.1.1 Create Power Plant

Supports creating power plants based on actual requirements.

8.2.1.1.1 Fill in Power Plant Information

Operation Steps

1. After logging into the App, if there is no power plant under the account, click "Create Power Plant"; if there are power plants under the account, click the "+" on the power plant list interface to enter the new power plant information filling page.
2. Follow the on-screen prompts and fill in the basic information such as power plant address, name, capacity, and power according to the actual situation.
3. If you need to add a power plant visitor, you can enter the organization code and power plant visitor information. Click "Complete" to create the new power plant.
4. Choose whether to add power plant equipment based on actual needs. If you need to add, please refer to the [8.2.1.1.2.Add Device\(Page 121\)](#) section.

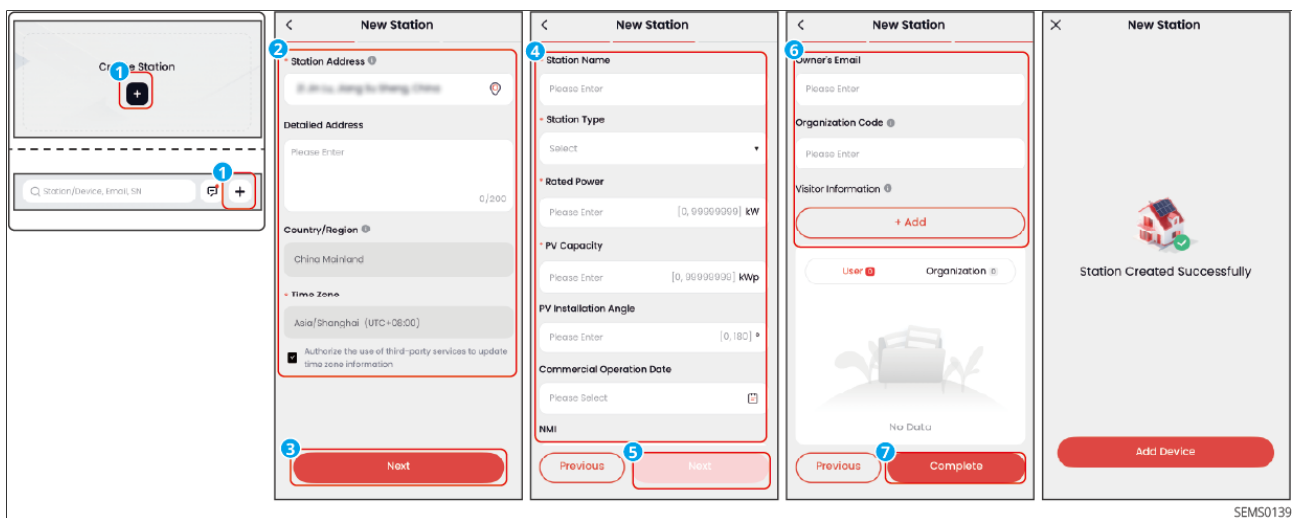

Figure3 Fill in Power Plant Information

Parameter	Function Description
Station Type	Set according to the actual station type. Supported: Residential Photovoltaic Station, Residential Energy Storage Station, Commercial & Industrial Energy Storage Station, Commercial & Industrial Photovoltaic Station.
Station Name	Set the station name according to actual requirements.
Rated Power	Set the total installed power of the station.
PV Capacity	Set the total installed PV capacity in the station.
Battery Capacity	Set the total battery capacity in the station.
PV Installation Angle	Set the installation angle of the PV panels.
Commercial Operation Date	Set the grid connection date of the station.

8.2.1.1.2 Adding Power Station Equipment

After the power station is created, you can add power station equipment based on actual needs.

- When a Home Energy Management System (HEMS) device has been added to the power station:
 - You can add devices associated under the HEMS; or add devices not associated with the HEMS, only monitoring all devices within the same power station.
 - Please use Bluetooth local connection to connect devices in the network such as energy storage inverters, charging piles, and smart switches to the same router as the HEMS. Otherwise, the HEMS cannot recognize these devices. For GoodWe products, please refer to the [8.3.1. Locally Connected Devices\(Page 145\)](#) section; for third-party products, please refer to the device user manual.

Manual Device Addition Steps

1. On the device list interface, click **+**.
2. Add the device according to actual needs. Select the device type, and scan the device SN or manually enter the device SN.
3. After scanning is complete, confirm whether the device serial number and verification code are correct. Modify the device name as needed. Click "Add Device" to complete the addition.
4. (Optional) To continue adding devices to the current power station, click **+**, and repeat the steps for entering the device SN.
5. (Optional) Click "Quick Configuration" to modify device settings such as safety regulations and working modes. For details, please refer to [8.2.1.1.3.Quick Configuration\(Page 124\)](#).
6. Click "Finish" to complete device addition.

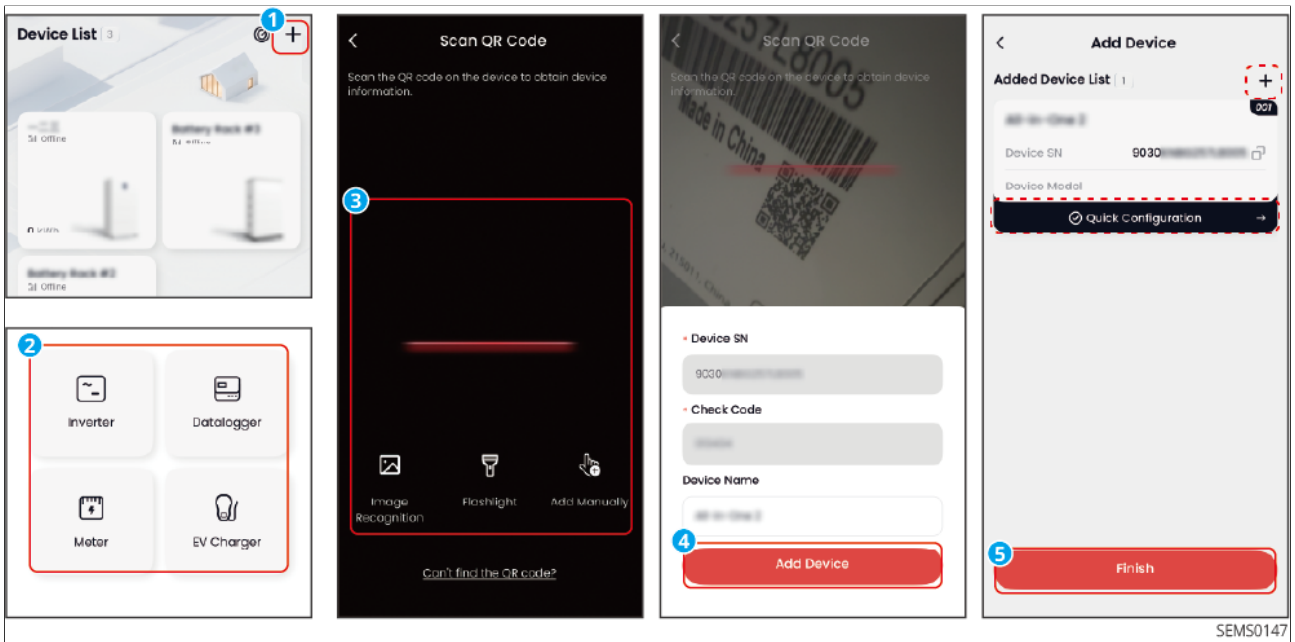

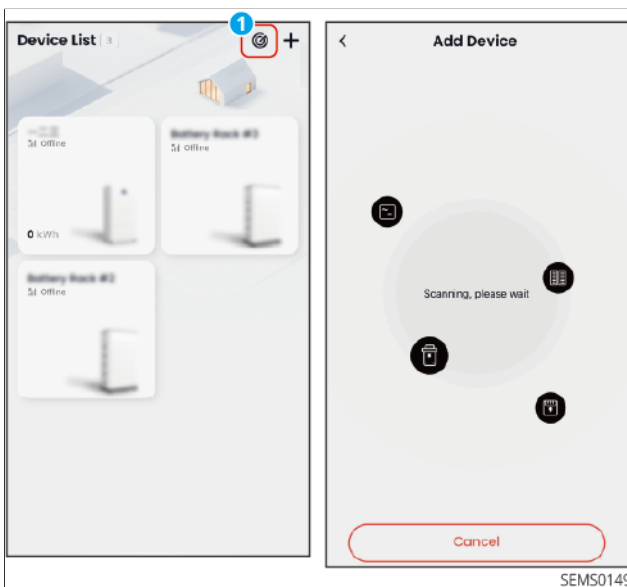

Figure4 Manually Adding Devices

Adding Devices via Scanning Steps

After manually adding an inverter to the power station, you can add associated devices of the inverter, such as batteries, via scanning.

1. On the device list interface, click .
2. Among the scanned devices, check the devices you need to add, and click "Add".
3. To continue adding other devices that were not scanned, click "Continue Adding", otherwise click "Finish".



8.2.1.1.3 Quick Device Configuration

Note

- After a device is first added to the power station, basic operation can be ensured through Quick Configuration.
- Before performing Quick Configuration, please confirm all devices are powered on and operating normally.
- The content of Quick Configuration varies by device type. Please refer to the actual interface.

Procedure

1. After adding the device, click "Quick Configuration" as prompted on the interface, or access the device list interface via "Account" > "Local Connection".
2. On the device list interface, select the "Bluetooth" or "WiFi" tab based on the signal type of the smart communication stick.
3. Pull down or click "Search for Devices". Confirm the inverter signal name according to the inverter serial number, then click to enter the quick configuration interface.
4. Complete the network configuration, safety code, work mode, etc., as prompted on the interface. For detailed information about work modes, refer to the [8.7.2.System Work Mode\(Page 175\)](#) chapter.
5. Click "Finish" to complete the quick configuration.

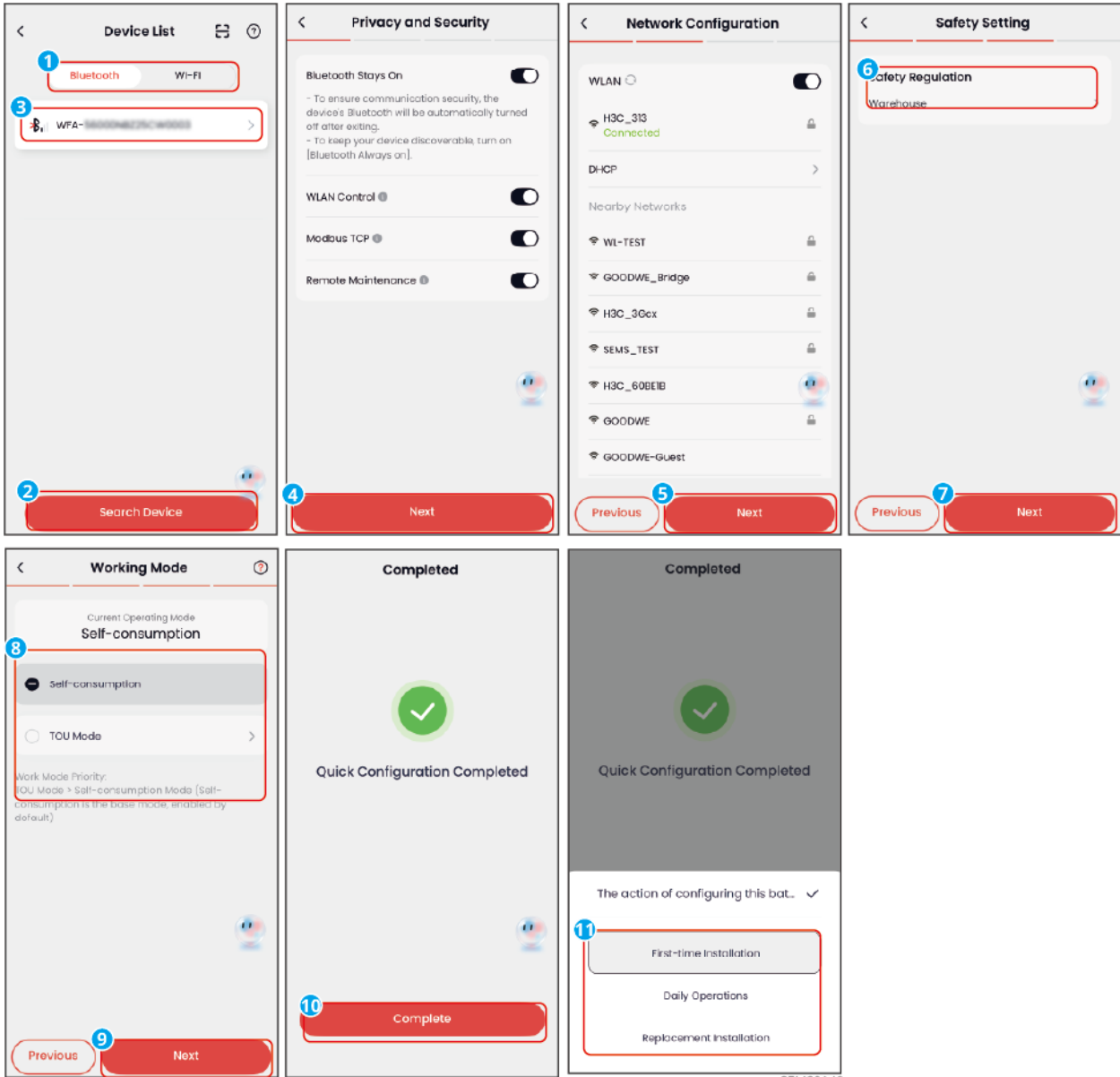

SEMS0148

8.2.1.2 View Power Plant Information (Installer)

8.2.1.2.1 Power Station List

After logging into the App with an installer account, you can view an overview of all power stations under the current account on the App's home page.

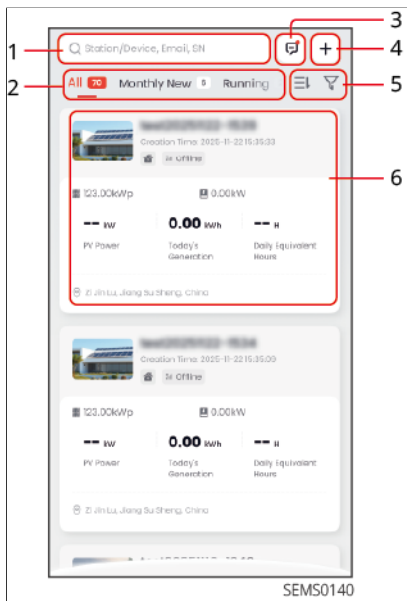

Figure6 Power Station List

No.	Description
1	Search for power plants. Enter plant information to quickly locate the plant you need to view.
2	Power plant operation status tabs. Click to quickly switch between plants under different operating statuses.
3	Plant Messages. View notifications such as plant alarms and events.
4	Click to create a new power plant.
5	<ul style="list-style-type: none"> Plant Sorting. Sort plants in ascending or descending order based on installed capacity or plant creation time. Filter Plants. Filter plants based on criteria such as plant type, rated power, and whether they are favorited.
6	<ul style="list-style-type: none"> Plant Card. Displays basic plant information such as plant name, operating status, power generation, and address. Click to enter the plant details interface. Long press to perform quick operations on the plant, such as favoriting, sharing, or deleting.

8.2.1.2.2 Power Station Details

On the power station list page, click on any station name to enter the station details interface. On the station details interface, you can view information such as basic station information, power generation, revenue, energy flow diagram, and environmental contribution.

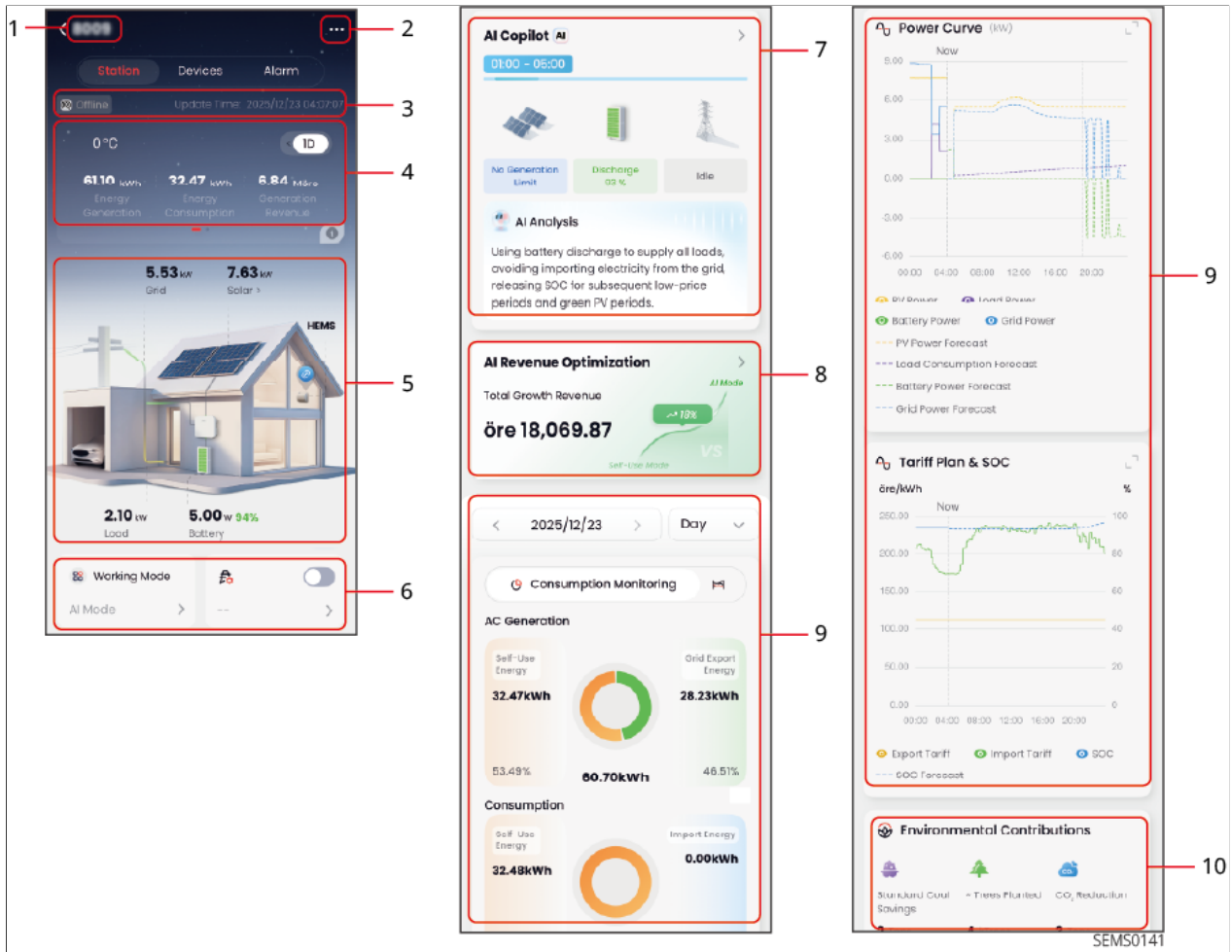

Figure7 Power Station Details

No.	Description
1	Current power station name.
2	Configure power station information. Supports: configuring basic power station information, sharing the power station, setting electricity price information.

No.	Description
3	Power station current operating status and update time.
4	<ul style="list-style-type: none"> • Current weather at the power station, and data such as power generation, electricity consumption, power generation revenue, electricity purchased from grid, grid feed-in revenue, etc. • Power station revenue statistics require electricity price configuration; otherwise, the system cannot calculate revenue data. • Currently, only revenue estimation via fixed electricity price is supported. • Power Generation Revenue: Displays the estimated power generation revenue for the current power station type. • Power Generation: Displays the total power generation for the current power station type. • Grid Feed-in Revenue: Displays the estimated revenue from selling electricity to the grid for the current power station type. • Grid Feed-in Electricity: Displays the total electricity fed into the grid for the current power station type.
5	Power station energy flow diagram display.
6	Quick access entry for common control settings.
7	<ul style="list-style-type: none"> • AI Energy Manager. Displayed when the system's AI mode is enabled, indicating the system is currently being managed and dispatched by AI. • Displays the current time period and the planned dispatch status of PV, energy storage, and the grid during this period. • Click the card to enter the AI Energy Manager details interface to view the detailed AI dispatch plan.

No.	Description
8	<ul style="list-style-type: none"> • Displayed when the system's AI mode is enabled. Compares Self-Consumption Mode with AI Mode, showing the economic revenue optimization. • Click the card to enter the Economic Revenue Optimization details interface to view AI operation days, revenue increase, expenditure comparison overview, revenue calendar, etc.
9	Power Consumption Monitoring, Energy Flow, Power Curve, Energy Monitoring Chart. Visual charts display the power station's operating status and energy dynamics.
10	Environmental Contribution. Displays the environmental benefits generated by PV power generation, including: CO2 emission reduction, standard coal saved, equivalent trees planted, etc.

8.2.1.2.3 Alarms

When logged in with an installer account, click "Alarms" on the homepage to view alarm information for all power plants under the account.

- By default, "All" alarms are displayed. You can switch between "Active" and "Recovered" faults using the status tabs.
- Long press an alarm to favorite, delete, or acknowledge it.

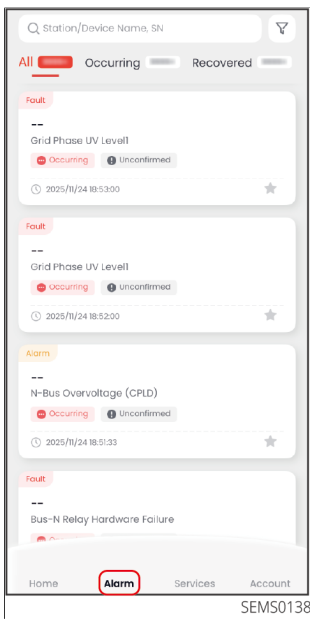

Figure8 Alarms

8.2.1.3 View Power Plant Information (Owner)

8.2.1.3.1 Power Station List

When there are multiple power stations under the owner account, you can view all stations via the sidebar and switch the station displayed on the homepage. The station list displays all power stations under the account, including self-built stations and shared stations. Features for shared stations may be limited; please refer to the actual interface.



Figure9 Power Station List

No.	Description
1	Query power plants. Input plant information to quickly locate the power plant you need to view.
2	Click to create a new power plant.
3	<ul style="list-style-type: none"> Power plant card. Displays basic plant information such as plant name, operational status, power generation, and address. Click to enter the power plant details interface. Long press to perform quick operations on the plant, such as favoriting, sharing, or deleting.

8.2.1.3.2 Power Station Details

After logging into the App with the owner account, you can view the details of a specific power station within the current account on the App's homepage. On the power station details interface, you can view basic information, power generation, revenue, energy flow diagram, environmental contribution, and other details of the power station.

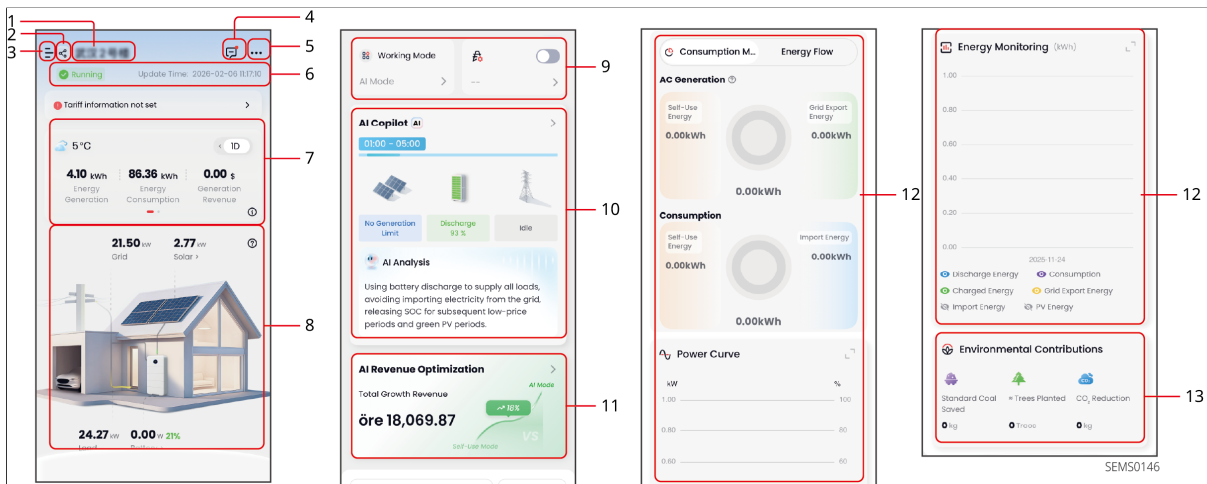

Figure10 Power Station Details

No.	Description
1	Current power station name.
2	Displayed when the station is a shared station.
3	Power station list. Click to expand all stations under the current account and switch quickly.
4	Station messages. View station alerts, events, and other message notifications.
5	Configure station information. Supports: configuring basic station information, sharing the station, setting electricity price information.
6	Current operating status of the station and update time.

No.	Description
7	<ul style="list-style-type: none"> • Current weather at the station and data such as power generation, electricity consumption, generation revenue, purchased electricity, grid feed-in revenue, etc. • Electricity price configuration is required for station revenue statistics; otherwise, the system cannot calculate revenue data. • Currently, revenue estimation is only supported via fixed electricity prices. • Generation Revenue: Displays the total generation revenue for the current station type. • Power Generation: Displays the total power generation for the current station type. • Grid Feed-in Revenue: Displays the total grid feed-in revenue for the current station type. • Grid Feed-in Electricity: Displays the total grid feed-in electricity for the current station type.
8	Display of the station's energy flow diagram.
9	Quick access for common control settings.
10	<ul style="list-style-type: none"> • AI Energy Manager. Displayed when the system's AI mode is enabled, indicating the system is currently being managed and dispatched by AI. • Displays the current time period and the planned dispatch status of PV, energy storage, and the grid during this period. • Click the card to enter the AI Energy Manager details page to view the detailed AI dispatch plan.
11	<ul style="list-style-type: none"> • Displayed when the system's AI mode is enabled. Compares self-consumption mode with AI mode, showing the economic benefit optimization. • Click the card to enter the Economic Benefit Optimization details page to view AI operation days, revenue increase, expenditure comparison overview, revenue calendar, etc.



No.	Description
12	Power consumption monitoring, energy flow, power curve, energy monitoring charts. Visualize station operation status and energy dynamics through charts.
13	Environmental Contribution. Displays the environmental benefits generated by PV power generation, including: CO2 emission reduction, standard coal saved, equivalent trees planted, etc.

8.2.1.4 Modify Power Station Basic Information

Supports modifying basic power station information, including station name, station type, rated power, battery capacity, PV capacity, station address, etc.

When modifying the station type, only switching to an energy storage station is supported; switching to a photovoltaic station is not supported.

Operation Steps

1. On the station details interface, click **...** to enter the station settings interface.
2. Click "Station Information" >  to modify the basic station information.
3. After modifying the information, click  to save the changes.

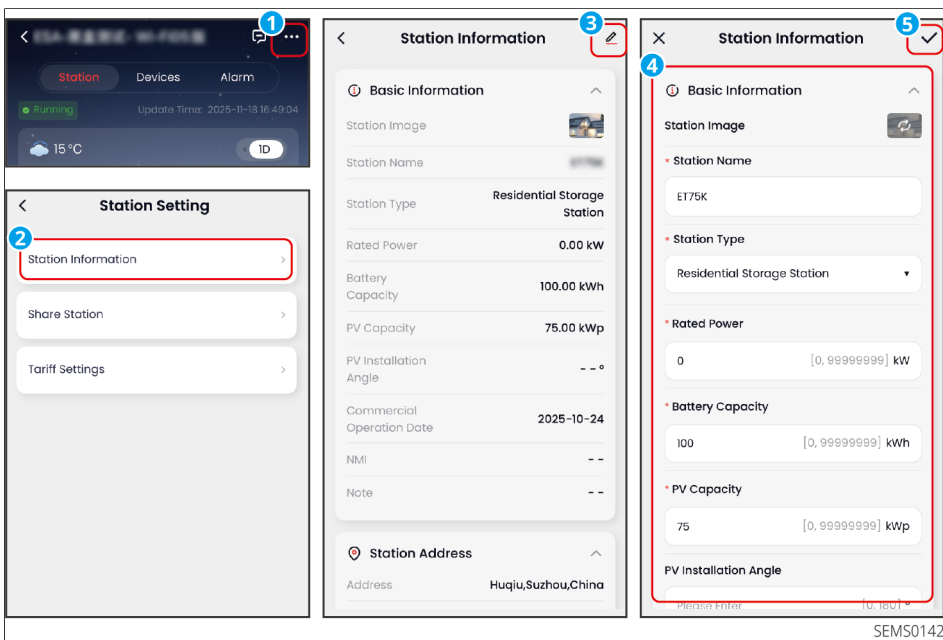

8.2.1.5 Configure Electricity Price Information

Supports viewing or setting the power station's electricity price information according to actual conditions.

Only some European countries or regions support using electricity market prices; currently, only Nord Pool is supported for the electricity market.

Operation Steps

1. On the power station details page, click **...** > "Electricity Price Settings" to enter the electricity price settings interface.
2. Select "Feed-in Tariff" or "Purchase Price". Then set the price type, which supports "Fixed Price", "Time-of-Use Price", and "Dynamic Price".
 - Fixed Price: Set by the user according to the actual electricity price.
 - Time-of-Use Price: The user sets the electricity price information for different time periods based on the actual price. Supports setting multiple price groups.
 - Dynamic Price: Obtains dynamic prices from the power company and dynamically adjusts the actual buying/selling electricity price combined with a user-set price surcharge. Only applicable in some regions and for some devices.
3. Click , enter the actual electricity price information and save.

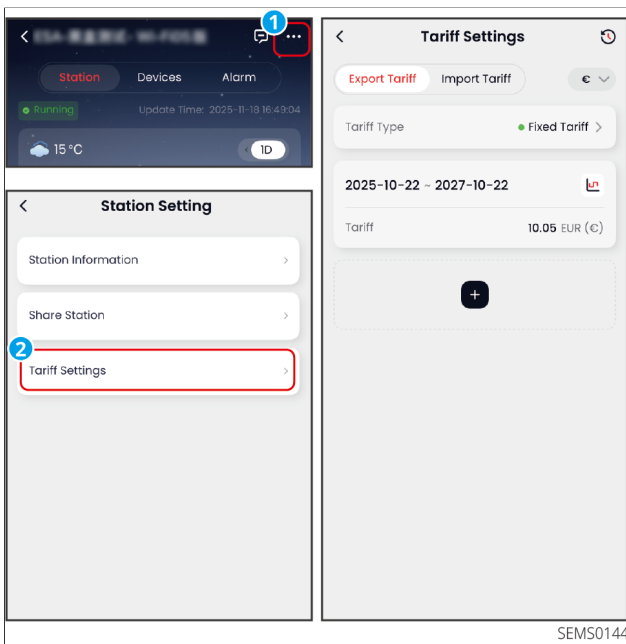

SEMS0144

Figure12 Configure Electricity Price Information

8.2.1.6 Manage Plant Sharing

After creating a plant, you can share it with other organizations or individual users, and set sharing permissions and time limits.

Procedure

1. On the plant details page, click **...** > "Share Plant" to enter the sharing interface.
2. Click "Add Share", fill in the recipient's information, and configure permissions and time limits as needed. To revoke a share after adding it, click .

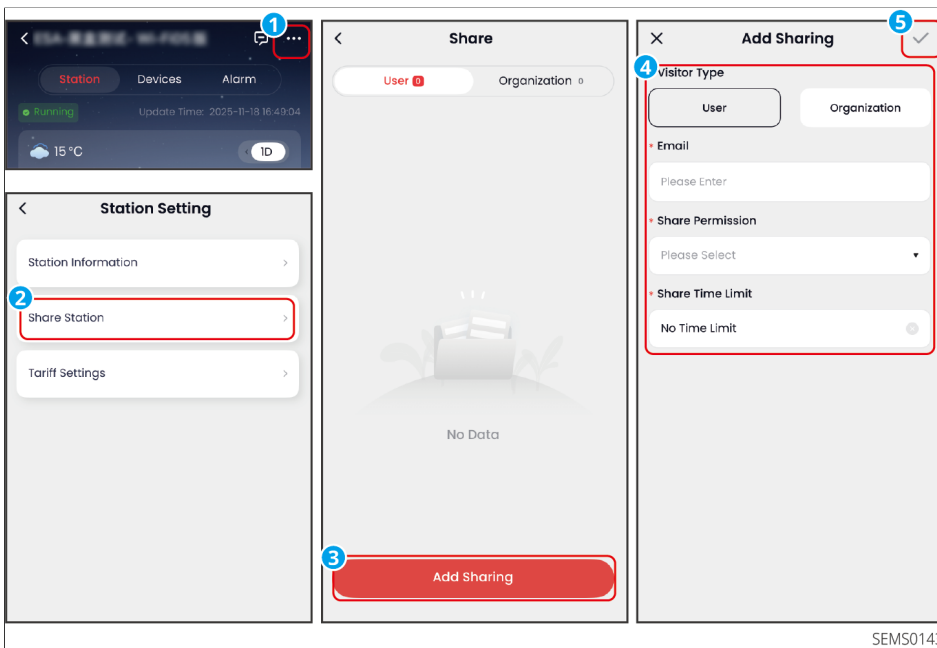

SEMS0143

Figure13 Manage Plant Sharing

8.2.2 Device

8.2.2.1 Device List

You can view an overview of all devices under your account on the Device List page, including device names, operational status, and more.

- When logged in with an installer account, select the desired power plant from the plant list to view the device list under that plant.
- When logged in with an owner account, click the "Device" tab to view the device list under the current power plant.

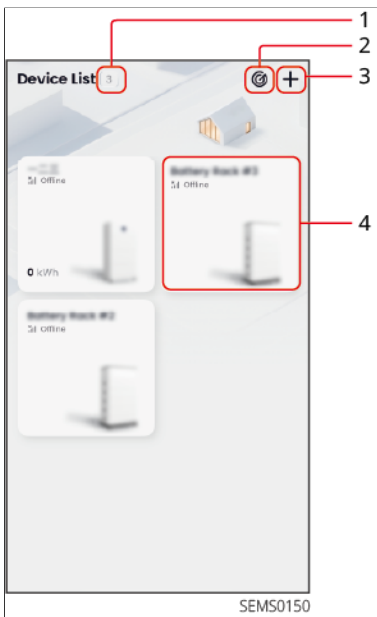

Figure14 Device List

No.	Description
1	The current number of devices within the power station.
2	Scan to add devices to the current power station.
3	Manually add devices to the current power station.
4	<ul style="list-style-type: none"> • Device Card. Displays data such as device name, device status, device illustration, power, and power generation. • The information displayed on the card varies depending on the device type. Please refer to the actual device. • The card layout varies depending on the power station type. Please refer to the actual power station. • The device card images are for reference only. Please refer to the physical product.

8.2.2.2 Device Details

On the device details interface, you can view device information, running status, power generation, power curve, or set device parameters such as grid connection parameters, safety regulation parameters, battery parameters, etc.



Figure15 Device Details

No.	Description
1	Device Name.
2	Device Operation Status.
3	Device Alarm Information. Click to view detailed alarm information.
4	When logged in with an Installer account, supports upgrading the device or viewing device upgrade records.
5	Power Generation Information. Displays today's power generation, cumulative power generation, etc.
6	Power Dashboard. Displays current power and rated power values.
7	<ul style="list-style-type: none"> Battery Information. Displays battery system SOC, charge/discharge status, charge/discharge power, etc. Click to enter the battery details interface.

No.	Description
8	<ul style="list-style-type: none"> • Remote Control. Displays quick access entries for common control items. • Click "More Controls" to view all control items for the device. • For details, please refer to the Setting Remote Control chapter.
9	<ul style="list-style-type: none"> • Operational Data. Displays current device operating parameters, such as active power, reactive power, power factor, etc. • Click "More" to display all data details. • The information displayed varies for different devices. Please refer to the actual interface.
10	Displays power curves and energy monitoring graphs within different time dimensions.
11	Device Details. Displays basic device information, such as device name, SN, device type, firmware version number, etc.

8.2.2.3 Remote Control Device

The controllable parameters may vary depending on the device model and the applicable national safety standards. Please refer to the actual device for details. For an explanation of device parameters, please refer to the [8.7.Appendix\(Page 169\)](#).

8.2.2.3.1 Setting Inverter Parameters

On the device list screen, select the inverter you need to configure and click "Settings" to set the inverter parameters according to your actual requirements.

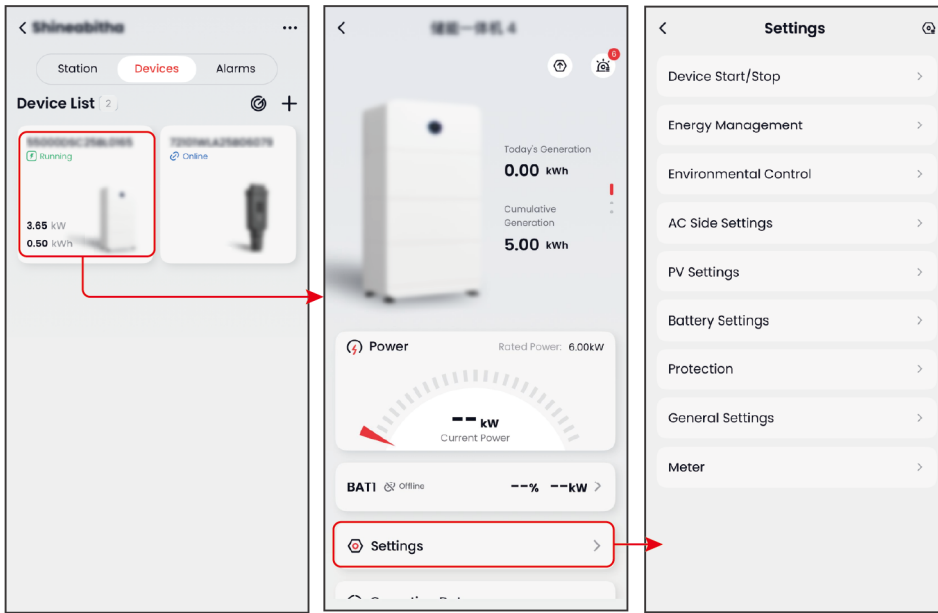

SEMS0177

Setting Safety Regulation Parameters Procedure

1. Navigate to the parameter setting interface via "Protection" > "Safety Regulations".
2. Set the safety regulation country and custom safety regulation parameters according to the actual situation. Custom safety regulation parameters can only be modified by the installer.

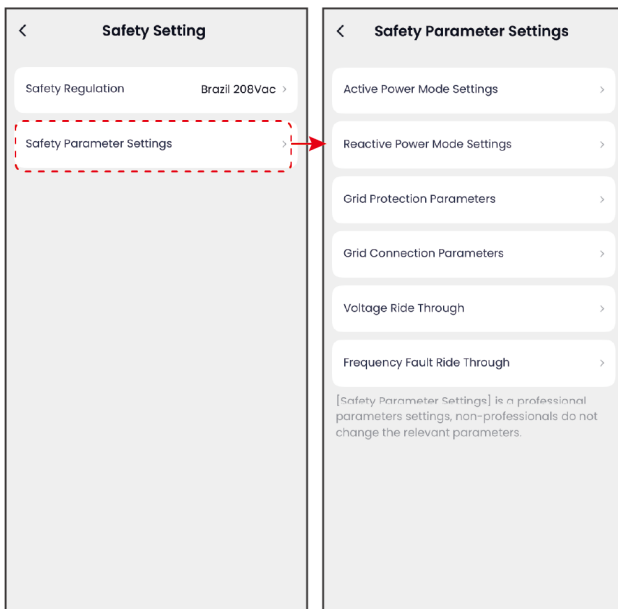

SEMS0166

Setting Power Limitation Parameters

Note

The power limit interface varies by country due to safety regulations. Please refer to the actual interface.

Procedure

1. Navigate to the power limitation setting interface via "Energy Management" > "Grid Power Scheduling" > "Grid Power Limitation".
2. Set the power limitation parameters according to your actual needs.



Setting Operation Mode

Note

- Only supports setting the operating mode for energy storage inverters.
- Different inverter models support different settable operating modes. Please refer to the actual interface.

Procedure

1. Navigate to the operation mode setting interface via "Energy Management" >

"Operation Mode".

2. Set the operation mode according to your actual needs.

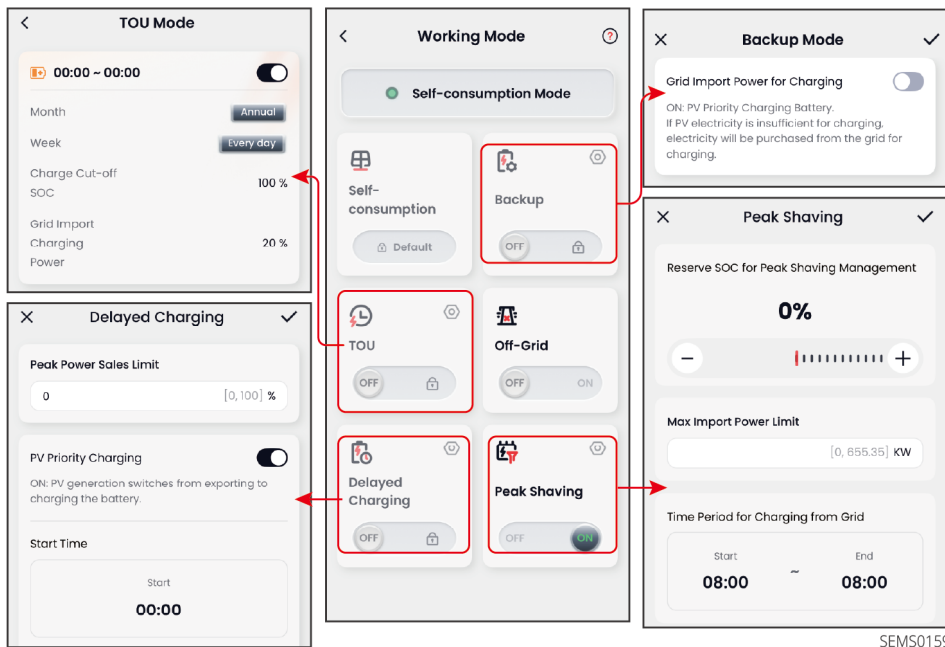

SEMS0159

8.2.2.3.2 Set Battery Parameters

Select the inverter in the device list interface, and select the battery to be configured in the inverter details interface. Click "Set" to configure the battery parameters according to your actual needs.

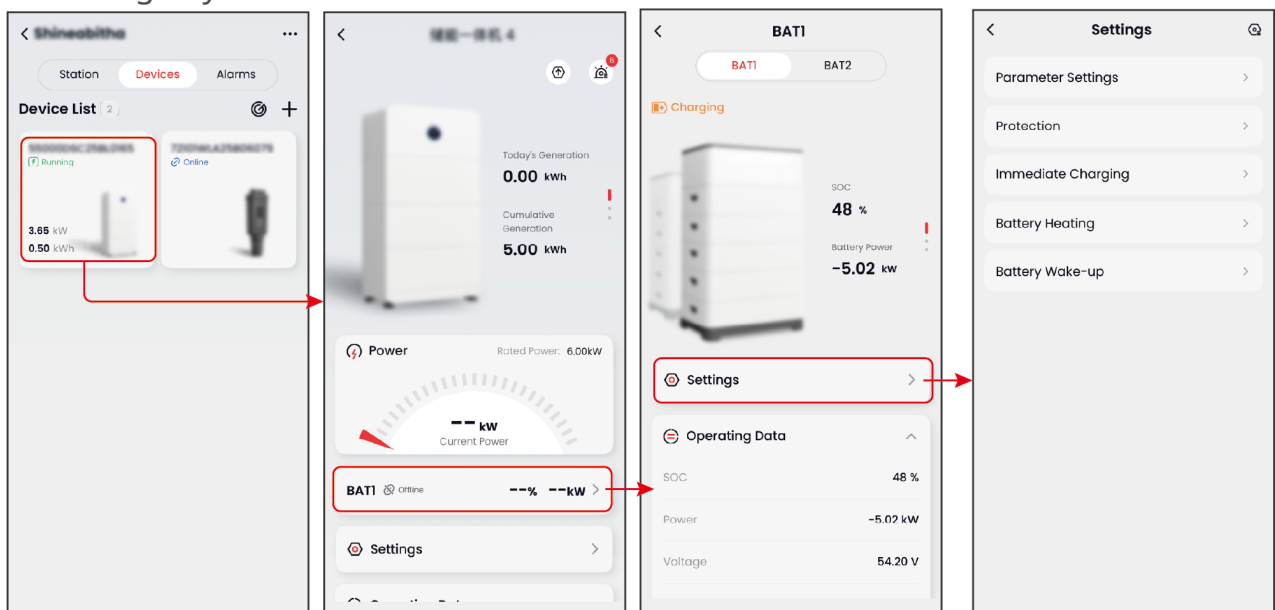

SEMS0178

8.2.2.3.3 Set Electricity Meter Parameters

Select the inverter in the device list interface, and click "Settings" > "Electricity Meter" to set the meter parameters according to your actual needs.

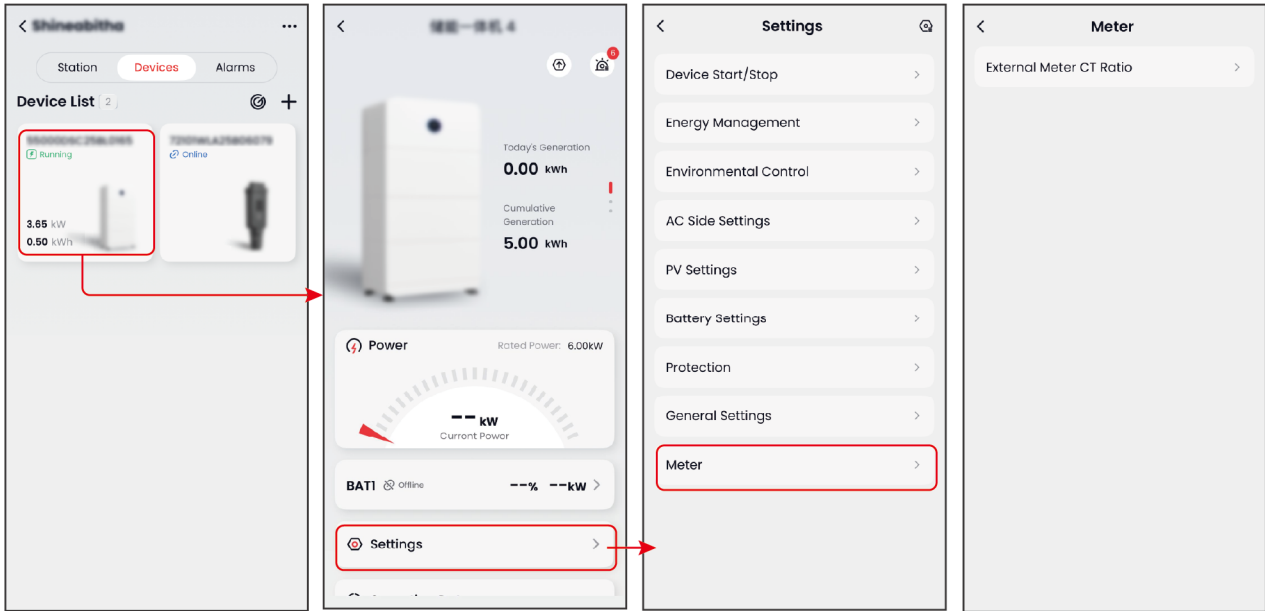

8.2.2.3.4 Configure Home Energy Management Device Parameters

On the device list interface, select the home energy management device and click "Settings" to configure parameters according to actual needs.

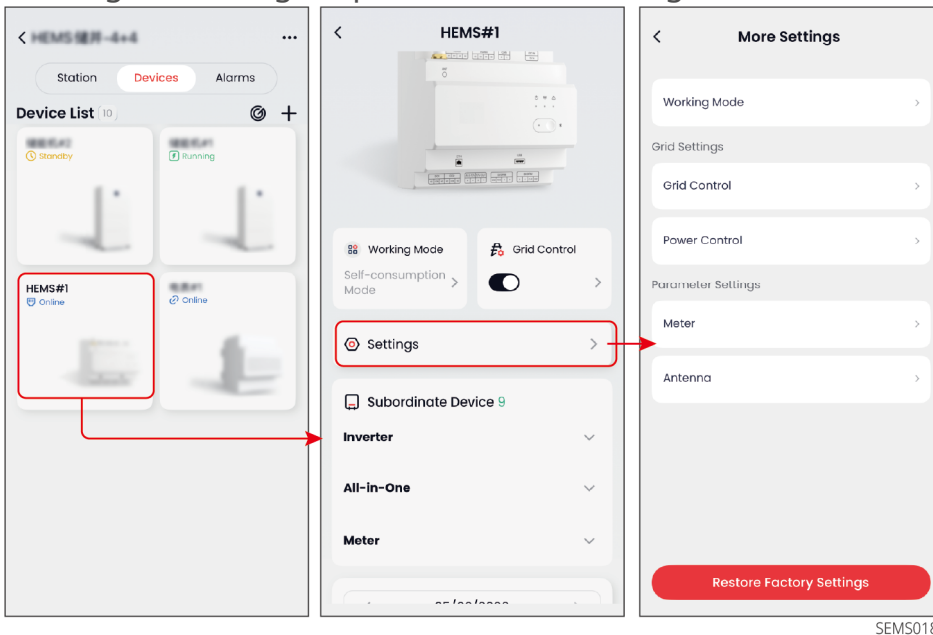

Set Working Mode

Operation Steps

1. Navigate to "Settings" > "Working Mode" to access the working mode configuration interface.
2. Set the working mode according to actual needs and the on-screen prompts.

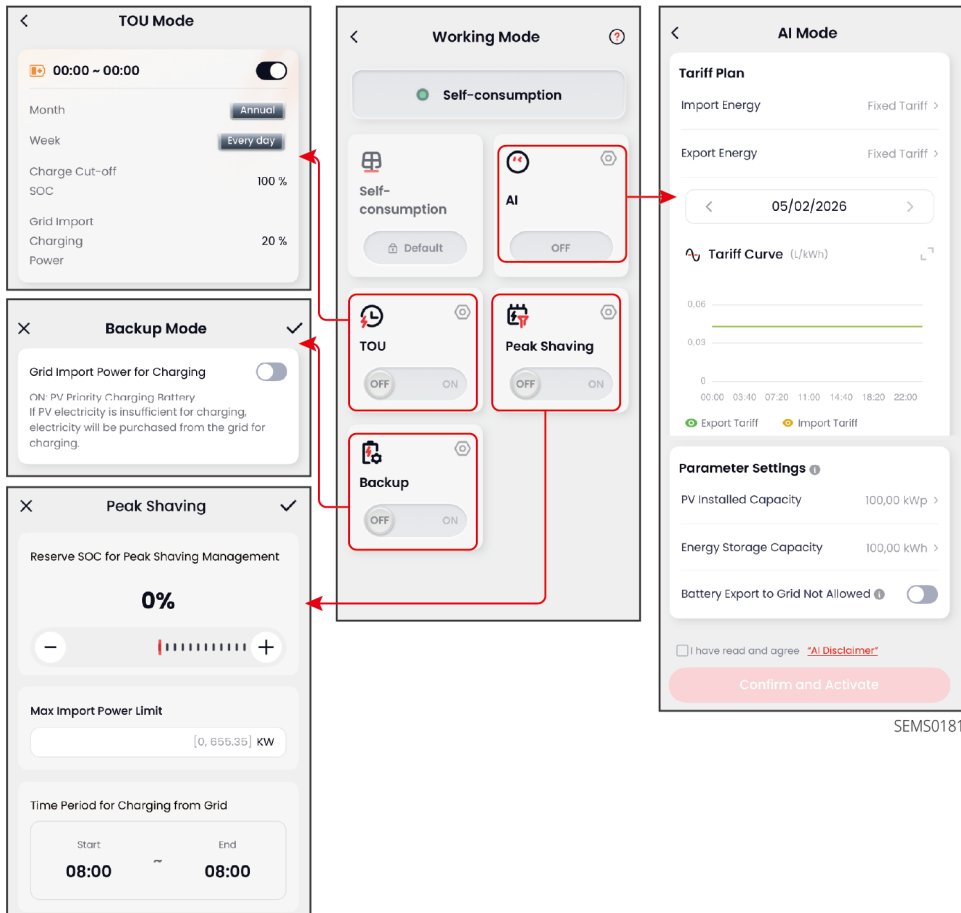

8.3 Local Debugging Device

Note

Power station information may vary depending on account type, region, and power station type.

After logging into the App with your account and password, you can connect the App to the device via Bluetooth or WiFi to locally view device information and configure device parameters.

8.3.1 Locally Connected Devices

Note

- Before connecting to the device locally, please ensure the device is powered on and operating normally.
- The displayed device name varies depending on the device type or smart communication stick type, as follows (***) represents the device serial number):
 - Wi-Fi/LAN Kit; Wi-Fi Kit; Wi-Fi Box: Solar-WiFi***
 - WiFi/LAN Kit-20: WLA-***
 - WiFi Kit-20: WFA-***
 - Ezlink3000: CCM-BLE***; CCM-***; ***
 - 4G Kit-CN-G20/4G Kit-CN-G21: GSA-***; GSB-***
 - 4G Kit-G20: LGA-***
 - Charging Pile: ***
 - EzManager3000: LEM-***

Operation Steps

1. After logging into the App, click "Service" > "Local Connection" to enter the connection interface.
2. On the "Device List" interface, select the "Bluetooth" or "WiFi" tab based on the smart communication dongle's signal type. Click "Search for Devices" to refresh the device list, and select the device you need to connect to by its serial number.
3. During the first login, enter the initial login password to log in and change the password as prompted on the interface. Initial login password: 1234.
4. When connecting via Bluetooth, please enable "Keep Bluetooth On" as prompted on the interface; otherwise, the Bluetooth signal will turn off after this connection ends.

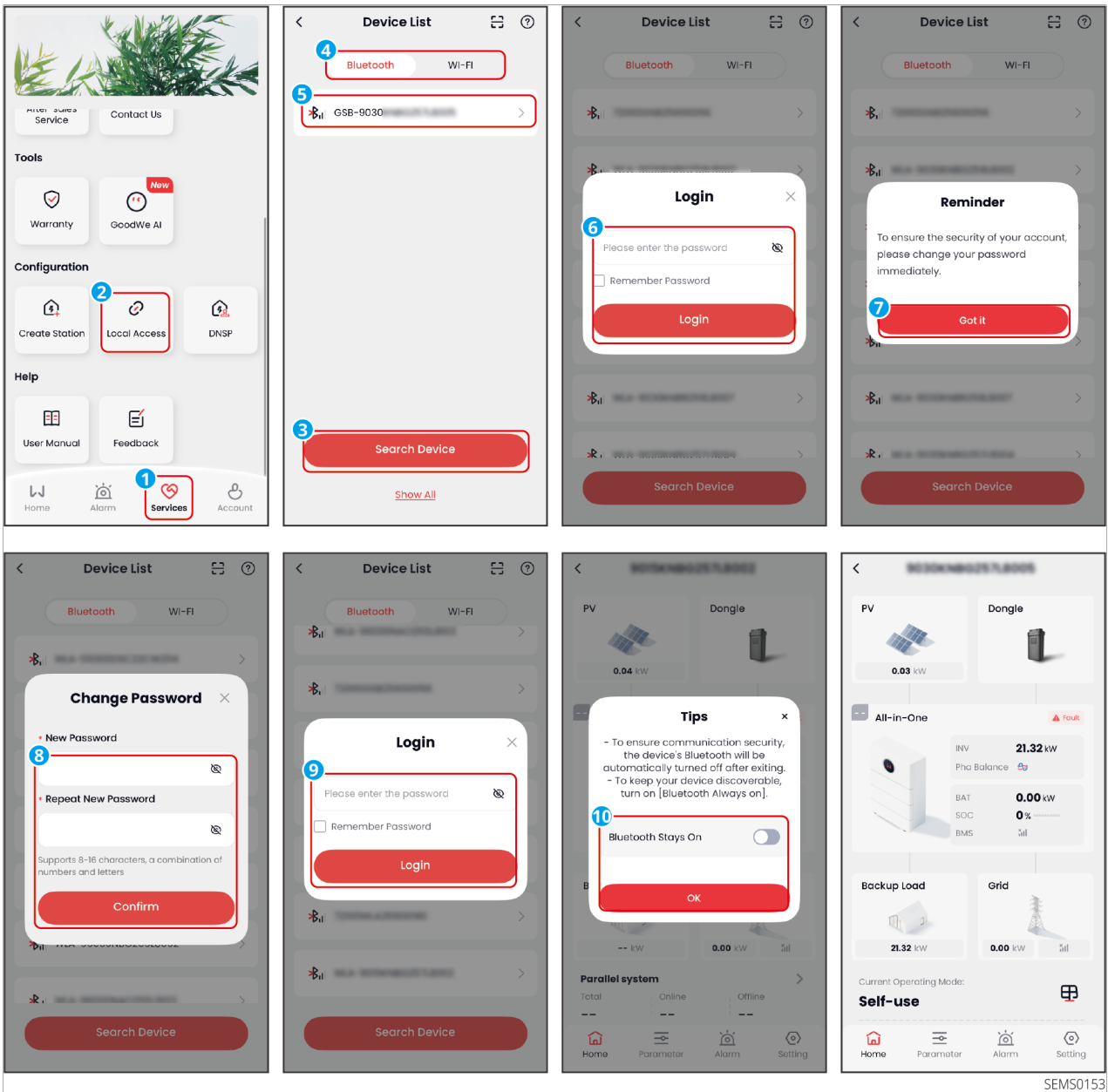

SEMS0153

Figure16 Locally Connected Device

8.3.2 Local Connection Interface Overview

Note

The App interface may vary depending on the devices included in your system. Please refer to the actual interface.

After connecting devices via Bluetooth or WiFi, you can access the local connection device interface. It supports viewing or modifying device parameters.

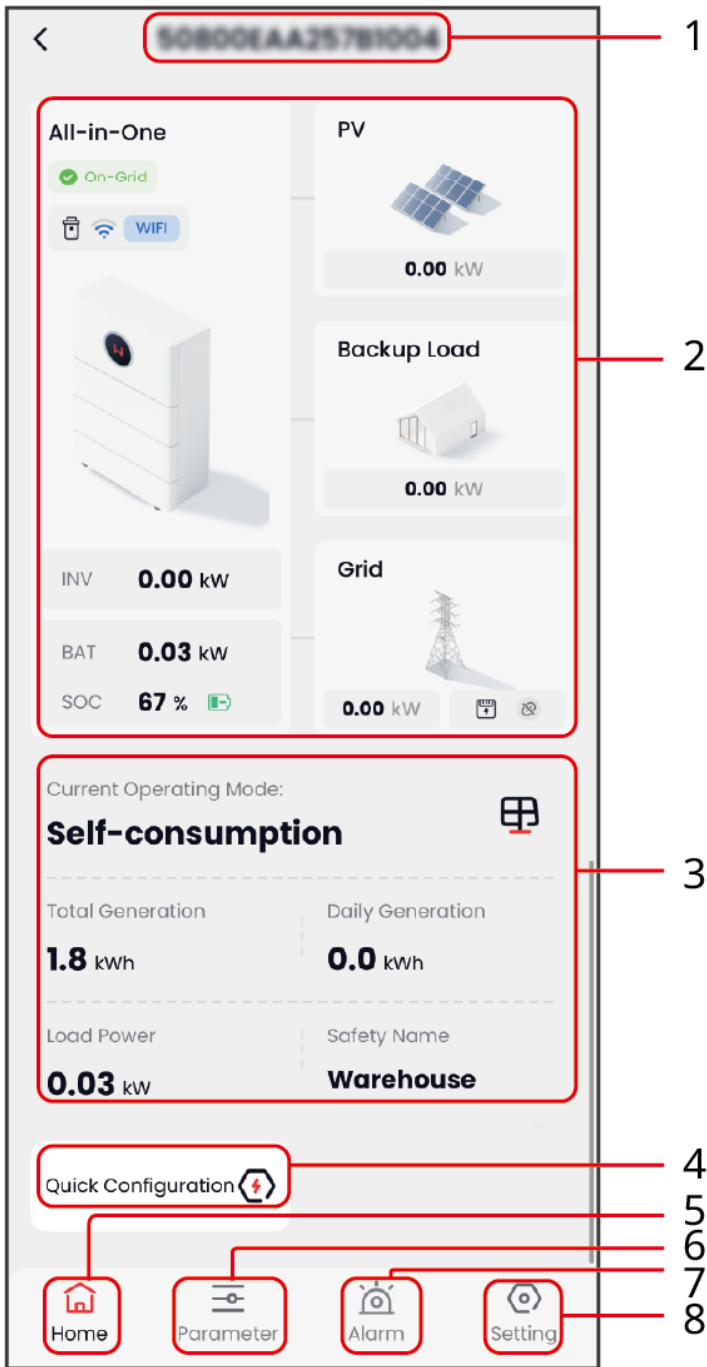

SEMS0154

No.	Description
1	Current device serial number.

No.	Description
2	<ul style="list-style-type: none"> • System module cards. Includes PV, communication module, inverter, grid, Backup load, and other cards. • Click a card to view related parameters and set parameter values. • When the inverter is an all-in-one unit, clicking the all-in-one unit card allows you to view information for the inverter, battery, and communication stick separately and set parameter values.
3	Current system operation information. Includes working mode, power generation, power, etc.
4	<p>Quick access to control items, for example:</p> <ul style="list-style-type: none"> • Quick Configuration. Quickly complete network settings, safety code settings, working mode settings, device self-check, and other functions to meet basic usage. For specific settings, please refer to the 8.2.1.1.3.Quick Configuration(Page 124) chapter. • Some models support "One-Click Configuration", which can generate a template based on the completed Quick Configuration.
5	Home. Displays system information, such as devices included in the system, system operation information, and provides quick access to view parameters and set parameters.
6	Parameters. View device model, serial number, firmware version, device operating parameters, etc., based on the device type.
7	<ul style="list-style-type: none"> • Alarms. Displays current device alarm information. • Click to view detailed information such as alarm type, alarm cause, and handling suggestions.
8	Settings. Displays configurable parameters according to the device type.

8.3.3 Set Device Parameters

After connecting to the device locally, you can modify device parameters according to

actual requirements.

8.3.3.1 One-Click Configuration

Some device models support the One-Click Configuration mode, which allows saving a quick configuration as a template and applying it rapidly.

After completing the quick configuration, connect to the device locally, click "One-Click Configuration" > "Generate Template" to save the current configuration as a configuration template. When needed, click "One-Click Configuration Mode" to quickly import the saved template.

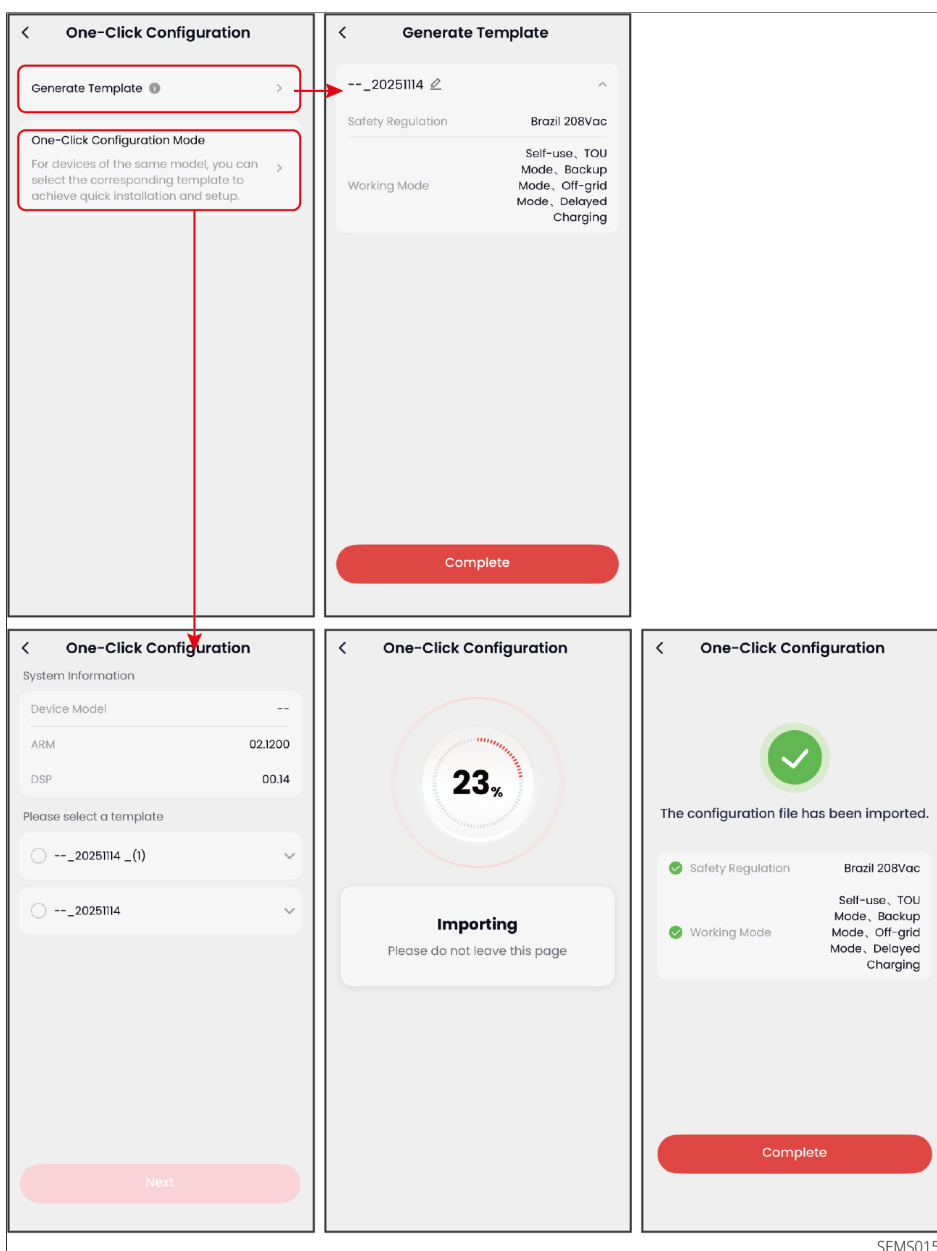

Figure17 One-Click Configuration

8.3.3.2 Setting Inverter Parameters

Method 1: On the "Home" page, select the inverter card, click "Inverter" > "Settings", and modify the device parameters according to actual needs.

Method 2: Click "Settings" and modify the device parameters according to actual needs.

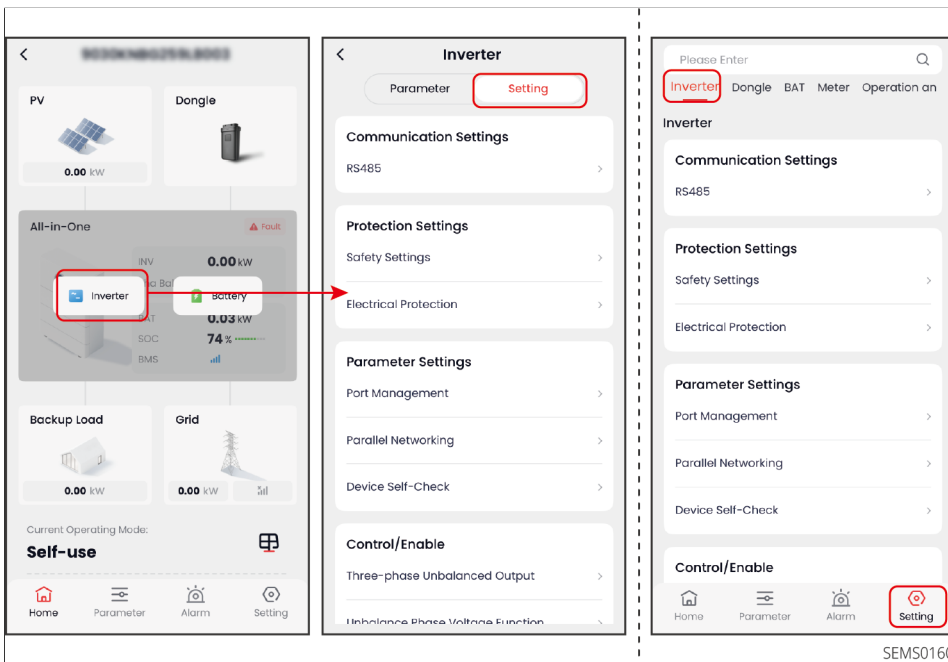
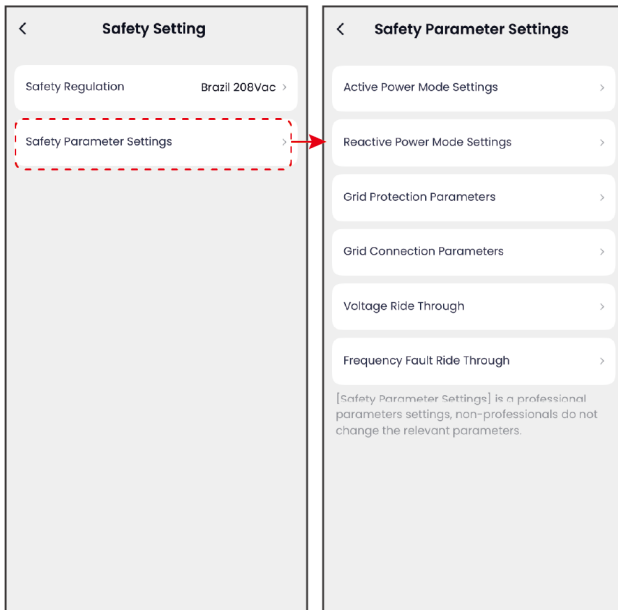

Figure18 Setting Inverter Parameters

Setting Safety Regulation Parameters

Operation Steps

1. Go to the parameter setting interface via "Settings" > "Safety Regulation Settings".
2. Set the safety regulation country and custom safety regulation parameters according to the actual situation. Custom safety regulation parameters can only be modified by installers.



SEMS0166

Setting Power Limitation Parameters

Note

The power limit interface varies by safety regulation country. Please refer to the actual interface.

Operation Steps

1. Go to the power limitation setting interface via "Settings" > "Grid-connected Power Scheduling" > "Grid-connected Power Limitation".
2. Set the power limitation parameters according to actual needs.



SEMS0182

Setting Working Mode

Note

- Only supports setting the working mode of energy storage inverters.
- Different inverter models support different working modes. Please refer to the interface for available options.

Operation Steps

1. Go to the working mode setting interface via "Settings" > "Working Mode".
2. Set the working mode according to actual needs.

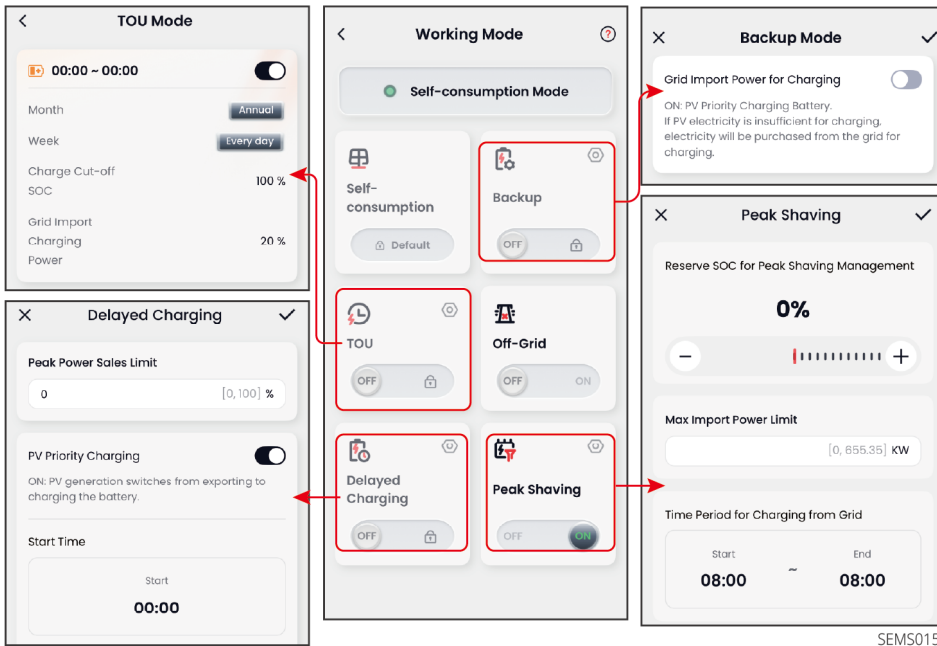

Setting RS485 Parallel Connection

Note

- When energy storage inverters are connected in parallel via RS485, each inverter must be configured separately via the App to confirm whether it is set as the master or slave unit.
- If an inverter from a parallel system needs to be used as a standalone unit, it must be set to standalone mode via the App.
- Please set the device connected to the meter as the master unit.
- Configure the slave inverter addresses first, then set up the parallel network via the master unit.

Operation Steps

1. Go to the setting interface via "Settings" > "Parallel Unit Networking".
 2. Set the inverter as the Master, Slave, or Standalone unit according to the actual wiring situation.
- When the inverter is the master unit, set it as the master and exit the connection. After completing the address setting for the slave inverters, return to this interface, click "Parallel Unit Networking", set the number of inverters in the parallel system, and then click "Networking".

- When the inverter is a slave unit, set the inverter address and click ✓.

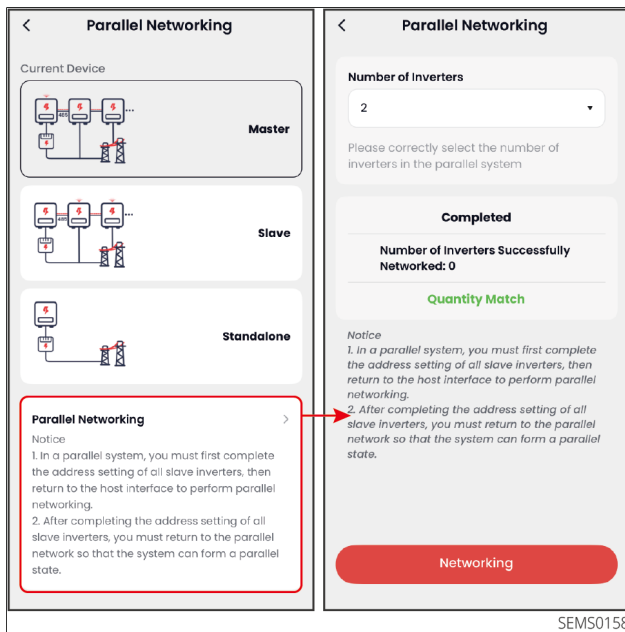

Figure19 Setting RS485 Parallel Connection

8.3.3.3 Configure Smart Communication Stick Parameters

Method 1: On the 'Home' page, select the communication module card, click on the device card > 'Settings', and modify the device parameters according to actual needs.

Method 2: Click 'Settings' and modify the device parameters according to actual needs.

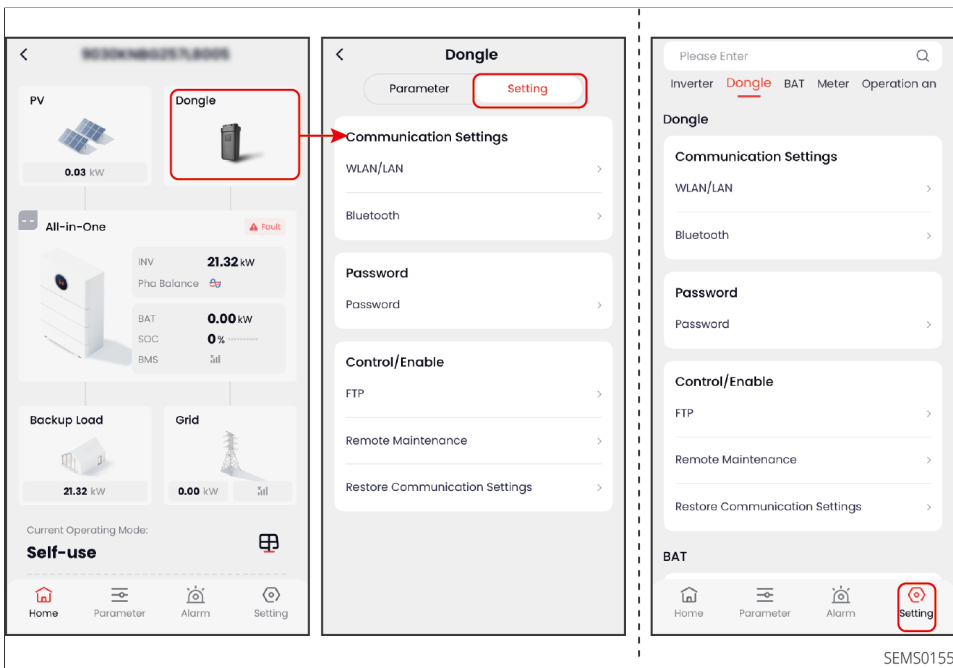

Figure20 Configure Communication Stick Parameters

8.3.3.4 Set Battery Parameters

Method 1: On the "Home" page, select the battery card, tap the card > "Settings", and modify the device parameters according to your actual needs.

Method 2: Tap "Settings", and modify the device parameters according to your actual needs.

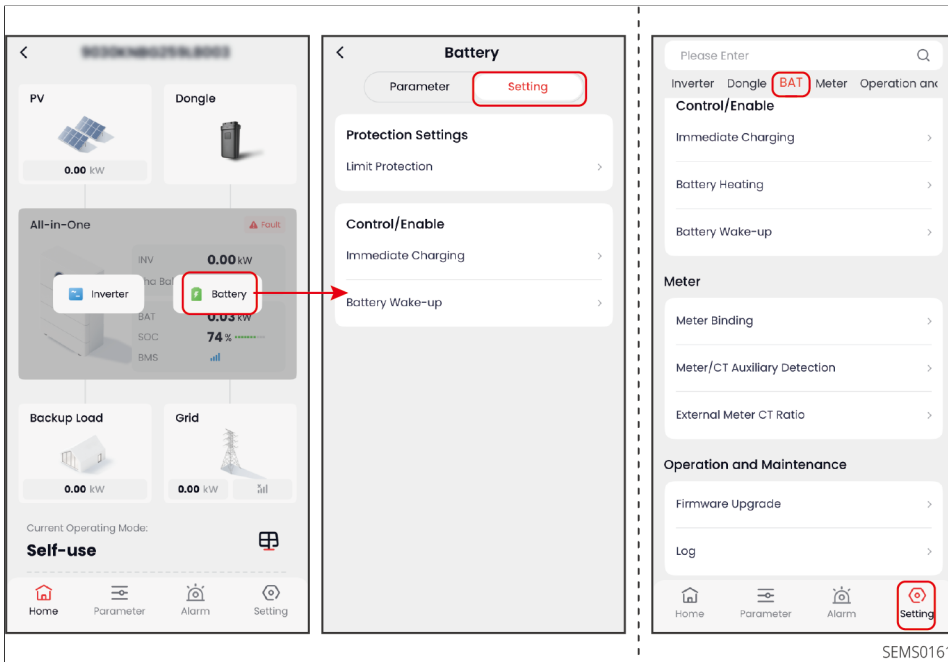

Figure21 Set Battery Parameters

8.3.3.5 Set Meter Parameters

Method 1: On the home page, long press the grid card, tap "Meter" > "Settings", and modify the device parameters according to your actual needs.

Method 2: Tap "Settings", and modify the meter parameters according to your actual needs.

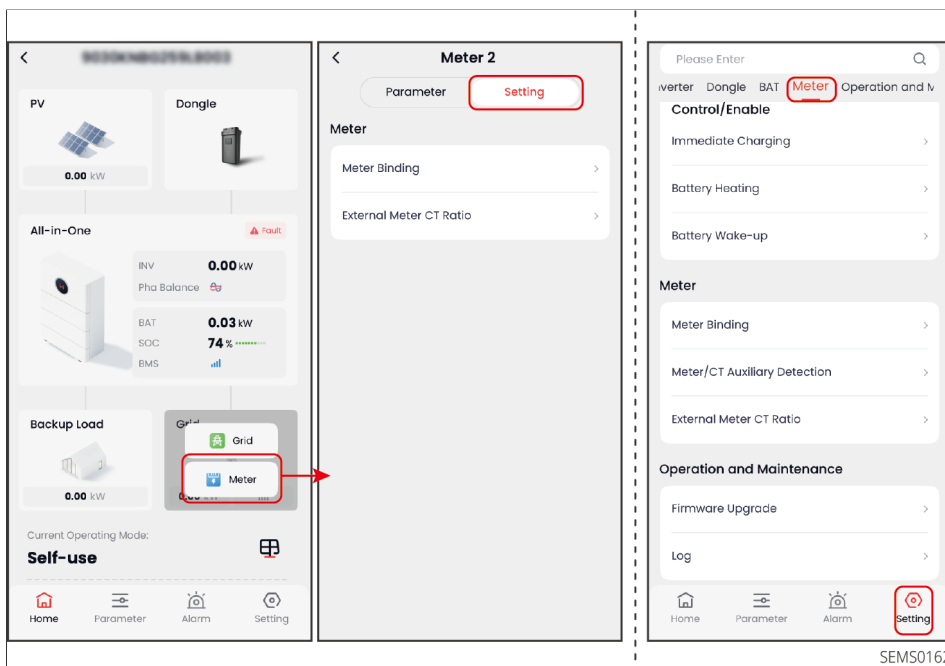

Figure22 Set Meter Parameters

Meter Binding Procedure

1. Tap "Home", long press the "Grid" card, select "Meter" > "Settings" > "Meter Binding" to enter the binding interface. Alternatively, enter via "Settings" > "Meter" > "Meter Binding".
2. Tap the "Meter Quantity/Location" dropdown to select the actual application scenario. Options include: Meter 1 (Built-in) No Meter 2; Meter 1 (External) No Meter 2; Meter 1 (Built-in) Meter 2 (External); Meter 1 (External) Meter 2 (External). This guide uses the Meter 1 (External) No Meter 2 interface as an example to demonstrate how to bind a meter.
3. As shown in the figure below, when selecting to use an external meter, you need to manually add the external meter information. Tap "Bind", then bind the meter by manually entering the meter SN or scanning the meter SN QR code. When the bound meter model is GM330, please set the meter CT ratio according to the actual situation; if using other meters, there is no need to set the meter CT ratio.

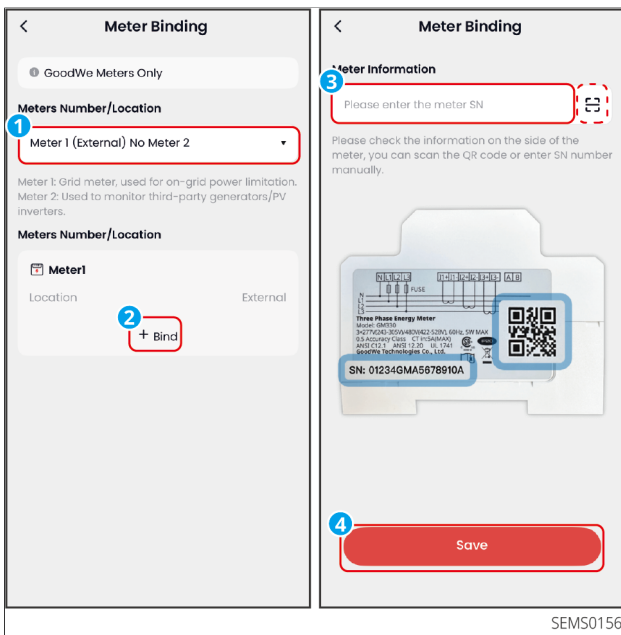

Figure23 Bind Meter

8.4 Services

Click "Services" to enter the service interface, where you can perform operations such as warranty inquiry, pre-sales and after-sales service, power station configuration, manual viewing, issue feedback, and AI invocation feedback.

Note

Different accounts have varying functional permissions. Please refer to the actual interface.

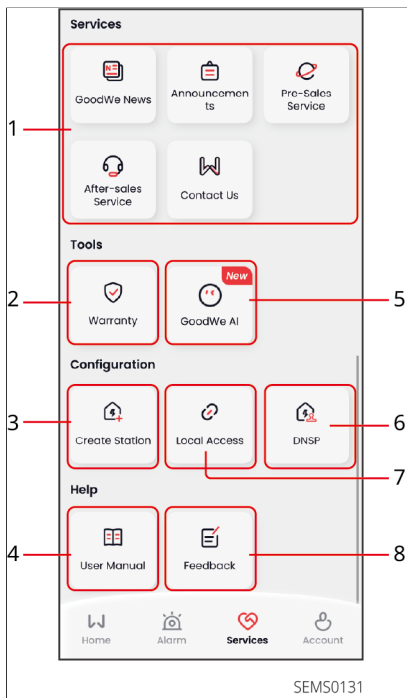

Figure24 Service Interface

No.	Description
1	Entry for news, announcements, and pre-sales/after-sales service.
2	Query warranty period by device serial number.
3	Create a power plant. For detailed steps, please refer to the Create Power Plant chapter.
4	View the App user manual.
5	<ul style="list-style-type: none"> AI Assistant. Quickly access knowledge base information, query business data, etc., through intelligent Q&A. Supports enabling the AI Assistant floating window for quick access to the conversation interface.
6	DNSP Settings. Applicable only to the Australia region.
7	Local Connection. For detailed steps, please refer to the Communication Settings chapter.

No.	Description
8	Report issues encountered during product use, optimization suggestions, etc.

8.4.1 Configure DNSP Function

Note

- Applicable to Australia only.
- Registering the user's power station with the DNSP network allows the electricity service provider to remotely limit the output power value of the photovoltaic power station.
- After DNSP registration, if operational anomalies occur, support is provided to detect DNSP issues (such as communication problems, firmware version issues, device time difference, etc.) through the installer account.

DNSP Registration Steps

1. Click "Service" > "DNSP" to enter the DNSP configuration interface.
2. Select an unregistered power station and click to enter the registration interface.
3. Fill in the registration information and submit.

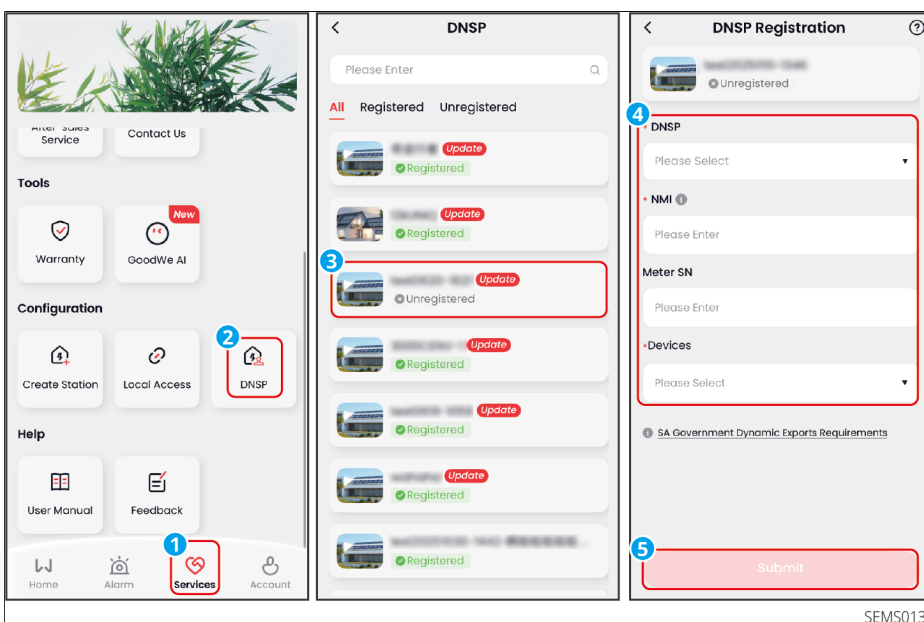

SEMS0132

Figure25 DNSP Registration

Parameter Name	Description
DNSP	Set the grid company.
NMI	National Meter Identifier. Set the NMI number.
Meter SN	Set the connected meter's SN number.
Device	Select a device already added in the power station. After selection, information such as the device serial number will be automatically filled.

DNSP Check Steps

1. Click "Service" > "DNSP" to enter the DNSP configuration interface.
2. Select a registered power station and click to enter the check interface.
3. Check for any abnormal information prompts, for example:
 - Whether the NMI number is correct;
 - Whether there is a time difference between the server and the device;
 - Whether the device status is online;
 - Whether the device version needs an upgrade;
 - Whether the device operating power is within the set range, etc.

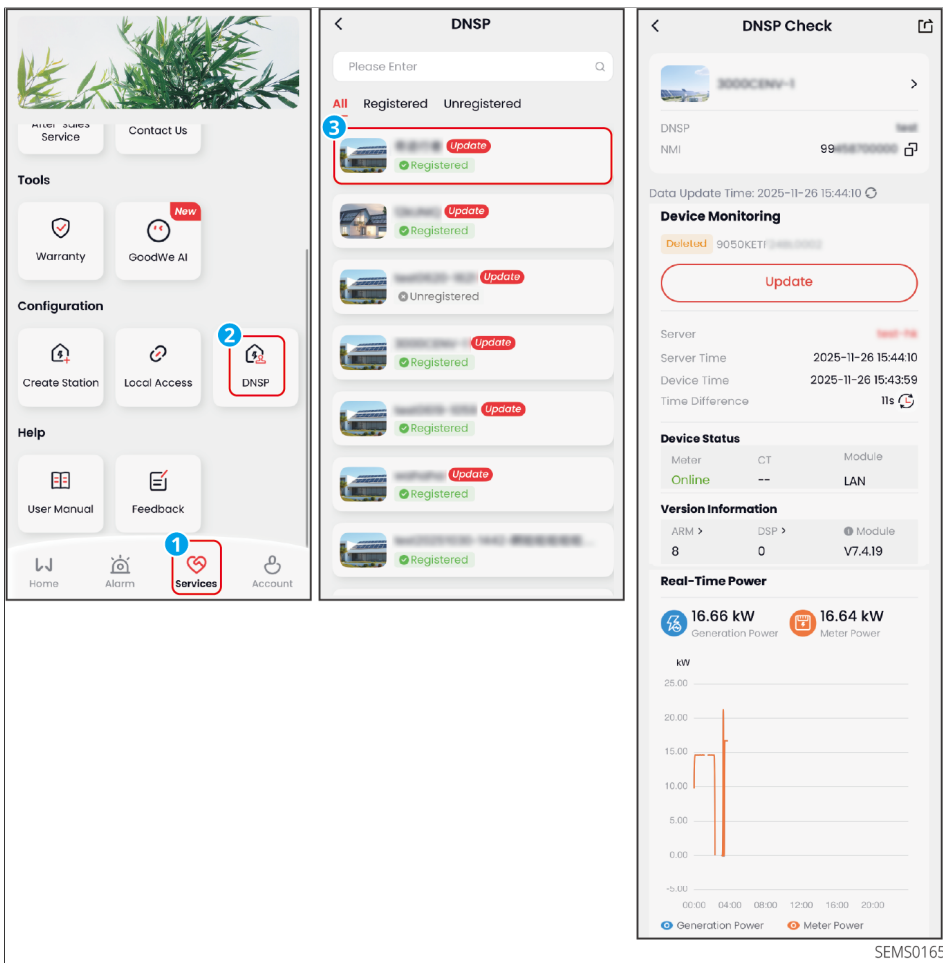

SEMS0165

Figure26 DNSP Verification

8.4.2 Using AI Assistant

Quickly obtain information with text and images through the GoodWe AI Assistant's Q&A format.

- Supports querying knowledge base information, such as GoodWe product device manuals.
- Supports querying business data, such as power generation information, fault information, power information, etc.
- Supports querying external data, such as weather information, date information, etc.

Operation Steps

1. Click "Service" > "GoodWe AI" to enter the AI Assistant interface.

2. Enter your question in the dialog box to quickly generate an answer.

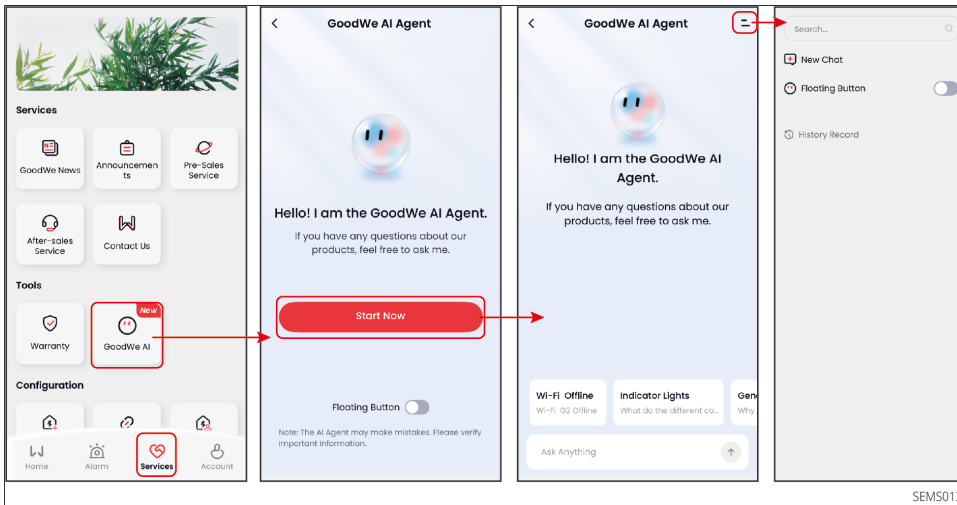

Figure27 AI Assistant

8.5 Account

8.5.1 Modify User Information

Supports modifying user-related information, such as username, avatar, country/region, etc.

Steps:

Click "Account" > "User Information" to enter the user information settings interface, where you can modify the relevant user information.

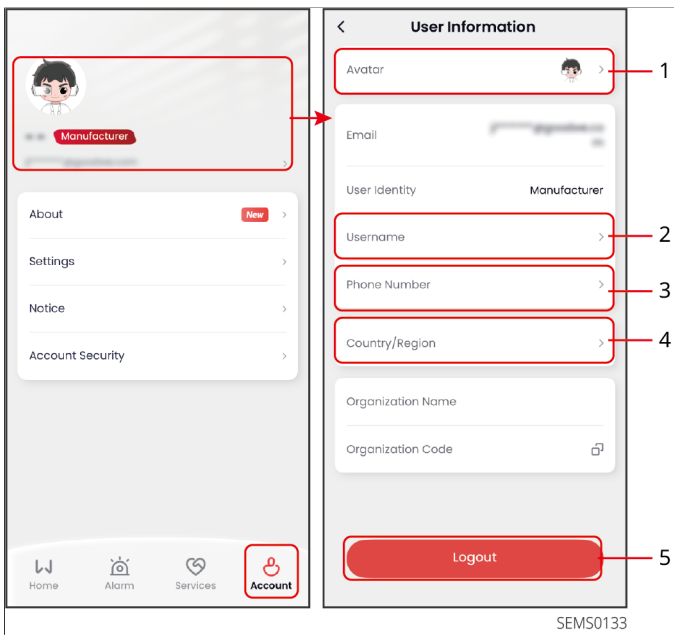

Figure28 Modify User Information

No.	Description
1	Change account avatar.
2	Change account username.
3	Bind account phone number.
4	Modify country/region information.
5	Log out of the currently logged-in account.

8.5.2 Configure App Notification Settings

Supports modifying App notification message types, delivery methods, time periods, etc.

Operation Steps

Tap "Account" > "Notifications" to enter the notification settings interface, where you can enable or disable message notifications, set message types, etc.

- Alert Subscription Configuration: When enabled, users can promptly receive notifications when device alarms occur.

- Supports setting push channels, i.e., receiving notifications via the App message center, email, etc.
- Supports setting when to push alarm notifications.
- Supports setting time periods and types for which notifications are not received.
- Shared Power Plant Subscription: Receive notifications when a new power plant is shared with you.

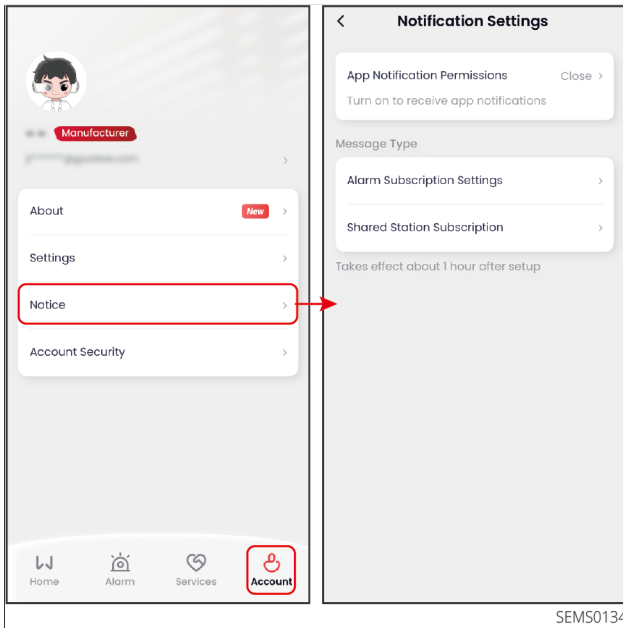

Figure29 Configure App Notification Settings

8.5.3 Set Account Security Information

To ensure account security, you can modify the email address bound to your account, your login password, and other information. It also supports deactivating accounts without power stations.

Steps

Click "Account" > "Account Security" to enter the security settings interface.

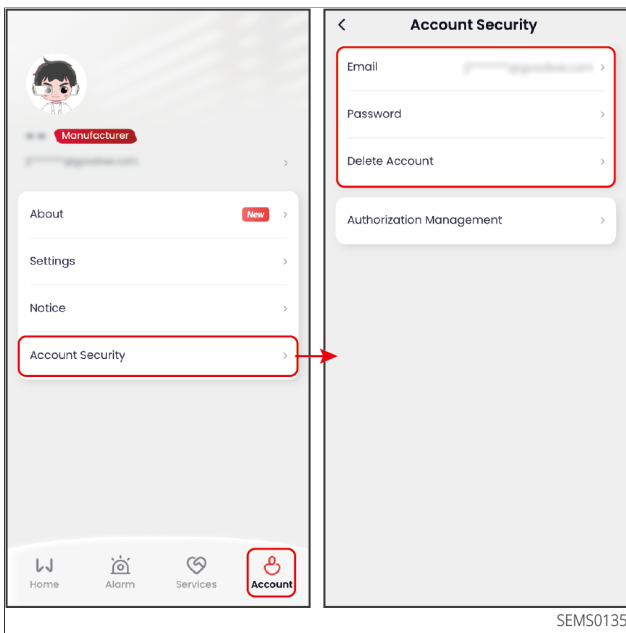

Figure30 Set Account Security Information

8.5.4 Set Monitoring Permissions

Note

- Applicable only to European and Australian servers.
- If third-party remote control is required, please contact the manufacturer to add authorization and fill in information such as battery capacity as prompted on the interface.
- Monitoring authorization is only applicable to the owner account. According to European GDPR regulations, the owner can set monitoring permissions and remote operation/maintenance permissions as needed. Accounts other than the owner and authorized visitors cannot monitor or operate/maintain this power station.

Procedure

1. Click "Account" > "Account Security" > "Authorization Management" to enter the security settings page.
2. Set monitoring permissions according to your actual needs.

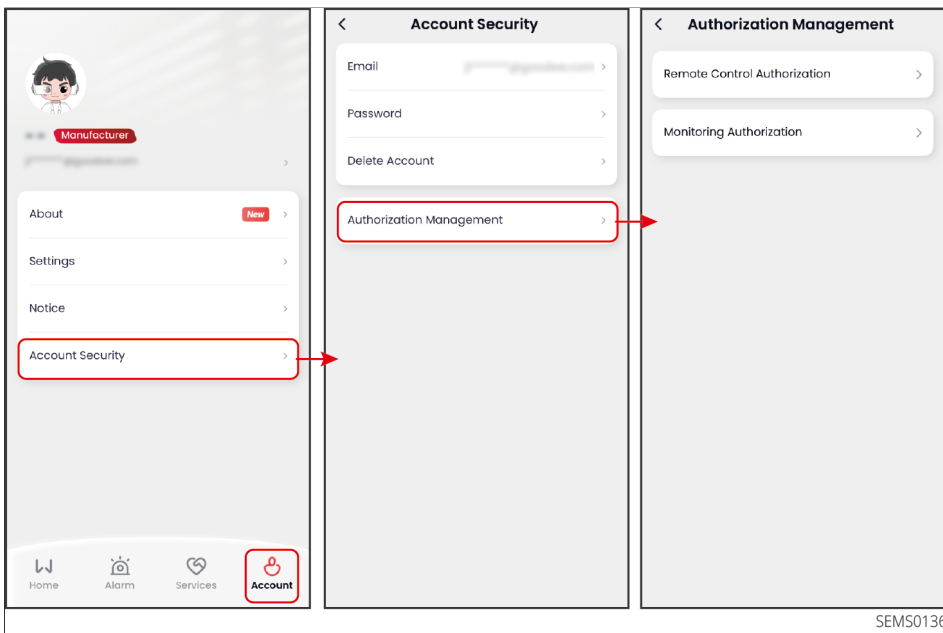

Figure31 Setting Monitoring Permissions

8.6 Fault Handling

Serial Number	Fault Name	Fault Cause	Handling Measures
1	Unable to Install App	<ol style="list-style-type: none"> 1. Mobile phone operating system version is too low. 2. The phone is blocking package installation. 	<ol style="list-style-type: none"> 1. Upgrade the mobile phone operating system. 2. In the phone's Settings > Security screen, check "Allow installation of apps from unknown sources".
2	Device WiFi Signal Not Displayed in App Device List	The App is not connected to a WiFi signal.	<ol style="list-style-type: none"> 1. Confirm the WiFi communication stick is working properly. 2. Refresh the device list. If the device still does not appear, exit and restart the App.

Serial Number	Fault Name	Fault Cause	Handling Measures
3	Login Failed	<ol style="list-style-type: none"> 1. The phone is not connected to the internet. 2. The App is under maintenance. 	<ol style="list-style-type: none"> 1. Check if mobile data is enabled on the phone and internet access is available. 2. The App is under maintenance. Please try again later.
4	Unable to Start App	<ol style="list-style-type: none"> 1. Mobile phone operating system version is too low. 2. App version is too low. 	<ol style="list-style-type: none"> 1. Upgrade the mobile phone operating system. 2. Confirm the App version is the latest.
5	Failed to Get Data During Operation	Communication between the device and the App is interrupted.	<ol style="list-style-type: none"> 1. Check if communication between the device and the router is normal. 2. Check if communication between the router and the cloud is normal.

8.7 Appendix

8.7.1 Compliance Countries

No.	Safety Standard Name	No.	Safety Standard Name
Europe			
1	IT-CEI 0-21	54	NI-G98
2	IT-CEI 0-16	55	IE-LV-16/25A
3	DE LV with PV	56	IE-LV-72A
4	DE LV without PV	57	IE-ESB-C&D(< 110kV)

No.	Safety Standard Name	No.	Safety Standard Name
5	DE-MV	58	IE-EirGrid-110kV
6	ES-A	59	PT-D
7	ES-B	60	EE
8	ES-C	61	NO
9	ES-D	62	FI-A
10	ES-island	63	FI-B
11	BE	64	FI-C
12	FR-LV	65	FI-D
13	FR-island-50Hz	66	UA-A1
14	FR-island-60Hz	67	UA-A2
15	type A-PL_V.1.1	68	EN 50549-1
16	type B-LV-PL_V.1.1	69	EN 50549-2
17	type C-PL_V.1.1	70	DK-West-B-MVHV
18	type D-PL_V.1.1	71	DK-East-B-MVHV
19	NL-16/20A	72	DK-West-C-MVHV
20	NL-A	73	DK-East-C-MVHV
21	NL-B	74	DK-West-D-MVHV
22	NL-C	75	DK-East-D-MVHV
23	NL-D	76	FR-Reunion
24	SE-A	77	BE-LV (>30kVA)
25	SE MV	78	BE-HV
26	SK-A	79	CH-B
27	SK-B	80	NI-G99-A
28	SK-C	81	NI-G99-B
29	HU	82	NI-G99-C
30	CH-A	83	NI-G99-D
31	CY	84	IE-LV-170kVA
32	GR	85	IE-MV&HV-200kVA

No.	Safety Standard Name	No.	Safety Standard Name
33	DK-West-A	86	DE-HV
34	DK-East-A	87	FR-MV
35	DK-West-B	88	CZ-A1/A2-09
36	DK-East-B	89	DE-EHV
37	AT < 1kV	90	IE-EirGrid-400KV
38	AT > 1kV	91	IE-EirGrid-220KV
39	BG	92	IE-EirGrid-66KV
40	Czech	93	IE-ESB-B
41	CZ-A1-09	94	IE-ESB-D(≥ 110 kV)
42	CZ-A2-09	95	type B-MV-PL_V.1.1
43	CZ-B1/B2-09	96	GB-G99-A HV
44	CZ-C	97	GB-G99-B LV
45	CZ-D	98	GB-G99-C LV
46	RO-A	99	UA-B
47	RO-B	100	UA-C
48	RO-D	101	UA-D
49	GB-G98	102	UK-G98
50	GB-G99-A LV	103	UK-G99-A LV
51	GB-G99-B HV	104	UK-G99-B LV
52	GB-G99-C HV	105	UK-G99-C LV
53	GB-G99-D	106	CZ-A1
Global			
1	60Hz-Default	6	IEC 61727-60Hz
2	50Hz-Default	7	Warehouse

No.	Safety Standard Name	No.	Safety Standard Name
3	127Vac-60Hz-Default	8	IEC61727-480Vac-60Hz
4	127Vac-50Hz-Default	9	IEC61727-480Vac-50Hz
5	IEC 61727-50Hz		
Americas			
1	Argentina-220V-LV	38	LUMAPR-2024-220Vac-3P
2	US-208Vac	39	LUMAPR-2024-240Vac-3P
3	US-240Vac	40	Cayman
4	Mexico-220Vac	41	Brazil-220Vac
5	Mexico-440Vac	42	Brazil-208Vac
6	US-480Vac	43	Brazil-230Vac
7	US-208Vac-3P	44	Brazil-240Vac
8	US-220Vac-3P	45	Brazil-254Vac
9	US-240Vac-3P	46	Brazil-127Vac
10	US-CA-208Vac	47	Brazil-ONS
11	US-CA-240Vac	48	Barbados
12	US-CA-480Vac	49	Chile-BT
13	US-CA-208Vac-3P	50	Chile-MT-A
14	US-CA-220Vac-3P	51	Chile MT-B
15	US-CA-240Vac-3P	52	Colombia
16	US-HI-208Vac	53	Colombia<0.25MW-208Vac-1P
17	US-HI-240Vac	54	Colombia<0.25MW-120Vac-3P
18	US-HI-480Vac	55	IEEE 1547-208Vac
19	US-HI-208Vac-3P	56	IEEE 1547-220Vac
20	US-HI-220Vac-3P	57	IEEE 1547-240Vac
21	US-HI-240Vac-3P	58	IEEE 1547-230Vac
22	US-Kauai-208Vac	59	Colombia<0.25MW-127Vac-3P
23	US-Kauai-240Vac	60	Colombia>5MW
24	US-Kauai-480Vac	61	Mexico-127V

No.	Safety Standard Name	No.	Safety Standard Name
25	US-Kauai-208Vac-3P	62	Mexico-240V
26	US-Kauai-220Vac-3P	63	US-O&R-208Vac
27	US-Kauai-240Vac-3P	64	US-O&R-240Vac
28	US-ISO-NE-208Vac	65	US-O&R-480Vac
29	US-ISO-NE-240Vac	66	US-O&R-208Vac-3P
30	US-ISO-NE-480Vac	67	US-O&R-220Vac-3P
31	US-ISO-NE-208Vac-3P	68	US-O&R-240Vac-3P
32	US-ISO-NE-220Vac-3P	69	Brazil-277Vac
33	US-ISO-NE-240Vac-3P	70	Chile-BT ≤9MW
34	LUMAPR-2024-208Vac	71	Chile-MT ≤9MW
35	LUMAPR-2024-240Vac	72	Chile > 9MW
36	LUMAPR-2024-480Vac	73	Mexico-277Vac
37	LUMAPR-2024-208Vac-3P		
Oceania			
1	Australia-A	4	Newzealand
2	Australia-B	5	Newzealand:2015
3	Australia-C	6	NZ-GreenGrid
Asia			
1	China A	33	Israel-MV
2	China B	34	Israel-HV
3	China Higher Voltage	35	Vietnam
4	China Highest Voltage	36	Malaysia-LV
5	China Power Station	37	Malaysia-MV
6	China Shandong	38	DEWA-LV
7	China Hebei	39	DEWA-MV
8	China PCS	40	Saudi Arabia-220V-LV

No.	Safety Standard Name	No.	Safety Standard Name
9	Taiwan	41	JP-690Vac-50Hz
10	Hong Kong	42	JP-690Vac-60Hz
11	China Northeast	43	Srilanka-MV/HV
12	Thailand-MEA	44	IEC 61727-127Vac-50Hz
13	Thailand-PEA	45	IEC 61727-127Vac-60Hz
14	Mauritius	46	JP-550Vac-50Hz
15	Korea	47	JP-550Vac-60Hz
16	India	48	India-Higher
17	India-CEA	49	JP-220Vac-50Hz
18	Pakistan	50	JP-220Vac-60Hz
19	Philippines	51	Saudi Arabia-127V-LV
20	Philippines-127Vac	52	Srilanka-LV >1MW
21	JP-200Vac-50Hz	53	China-YN
22	JP-200Vac-60Hz	54	GB/T 29319-LV
23	JP-440Vac-50Hz	55	GB/T 29319-MV
24	JP-440Vac-60Hz	56	Philippines -277Vac
25	JP-420Vac-50Hz	57	JP-360Vac-50Hz
26	JP-420Vac-60Hz	58	JP-360Vac-60Hz
27	JP-480Vac-50Hz	59	JP-320Vac-50Hz
28	JP-480Vac-60Hz	60	JP-320Vac-60Hz
29	Srilanka-LV<1MW	61	JP-340Vac-50Hz
30	Singapore	62	JP-340Vac-60Hz
31	Israel-OG	63	JP-380Vac-50Hz
32	Israel-LV	64	JP-380Vac-60Hz
Africa			
1	Mauritius	5	Ghana-LV
2	South Africa-LV	6	Ghana-HV

No.	Safety Standard Name	No.	Safety Standard Name
3	South Africa-B-MV	7	South Africa-A3-LV
4	South Africa-C-MV	8	Nigeria

8.7.2 System Operation Modes

Note

The PV-storage system supports setting the system operation mode. The default operation mode is self-consumption mode.

Operation mode priority: demand management > delayed charging > TOU > backup > self-consumption.

Self-consumption

The basic operation mode of the system. PV generation primarily supplies power to the loads, excess power charges the battery, and any remaining surplus is sold to the grid. When PV generation cannot meet the load demand, the battery supplies power to the loads. If the battery is also insufficient, the grid supplies power to the loads.

Backup Mode

Recommended for areas with unstable grid. When the grid fails, the inverter switches to off-grid operation mode, with the battery discharging to power the loads and ensure the BACKUP loads remain powered. When the grid is restored, the inverter switches back to grid-tied operation.

Parameter Name	Description
Grid Purchase Charging	Enable this function to allow the system to purchase electricity from the grid.
Charging Power	The percentage of the inverter's rated power used when purchasing electricity.

TOU Mode

Subject to local laws and regulations, buy and sell electricity during different time periods based on peak and off-peak grid electricity prices. According to actual needs,

the battery can be set to charge mode during off-peak hours, purchasing electricity from the grid for charging. During peak hours, the battery can be set to discharge mode to supply power to the loads.

Parameter Name	Description
Start Time	Within the specified start and end time, the battery charges or discharges according to the set charge/discharge mode and rated power.
End Time	
Charge/Discharge Mode	Set to either charging or discharging based on actual requirements.
Charging Cut-off SOC	Charging stops when the battery's state of charge reaches the set SOC.
Grid Charging Power	The percentage of the inverter's rated power used during charging.
Battery Discharge Power	The percentage of the inverter's rated power used during discharging.

Off-grid Mode

Suitable for areas without a grid. PV and the battery form a pure off-grid system. PV generation supplies power to the loads, with excess power charging the battery. When PV generation cannot meet the load demand, the battery supplies power to the loads.

Demand Management

Primarily applicable to scenarios with limited peak power purchase. When the total load power consumption exceeds the electricity quota within a short period, battery discharge can be utilized to reduce the portion of consumption exceeding the quota.

Parameter Name	Description
Reserved SOC for Demand Management	In Demand Management mode, the demand management function is active when the battery SOC is below the reserved SOC for demand management. When the battery SOC is higher than the reserved SOC for demand management, the demand management function becomes inactive.
Grid Purchase Power Peak Limit	Sets the maximum power limit allowed for purchasing electricity from the grid. When the load power consumption exceeds the sum of the power generated by the PV system and this limit, the battery discharges to supplement the excess power.
Grid Charging Time Period	During the grid charging time period, the battery can be charged from the grid when the load power consumption does not exceed the grid purchase quota. Outside this time period, the battery can only be charged using the PV generation power.

Delayed Charging

Suitable for areas with grid-tied power output limitations. By setting a peak power limit and charging time periods, PV generation exceeding the grid-tied limit can be used to charge the battery, reducing PV waste.

Parameter Name	Description
Feed-in Peak Power Limit	Set the peak power limit according to grid standard requirements in certain countries or regions. The peak power limit value must be lower than the local regulated output power limit.
PV Priority Charging	Within the charging time range, photovoltaic power generation is prioritized for charging the battery.
Start Charging Time	

AI Mode

AI Mode can be enabled when a Home Energy Management System (HEMS) device is used in the system.

Set electricity prices according to user needs, and combine with AI calculation for

optimized scheduling to maximize energy and economic efficiency. When using AI Mode, during the initial stage of collecting station information, there may be discrepancies between the prediction curve and actual data.

Select Time-of-Use (TOU) or Dynamic Pricing, supporting:

- Dynamic Pricing: Obtain dynamic electricity prices from the power company, and combine with user-set price surcharges to dynamically adjust the actual buy/sell electricity prices.
- Time-of-Use (TOU) Pricing: Users set electricity price information for different time periods based on actual rates. Supports setting multiple price groups.

8.7.3 Inverter Parameters

Communication Parameters

Parameter Name	Description
RS485 Settings	Sets the host communication address of the inverter. For a single inverter, please set the communication address according to the actual situation. When multiple inverters are connected, each inverter must have a different address, and none of the inverters should set the communication address to 247.

Device Start/Stop Parameters

Parameter Name	Description
Start	Controls device start, stop, and restart.
Stop	
Restart	

Environmental Control Parameters

Parameter Name	Description
Fan Control	

Parameter Name	Description
Fan Reverse Dust Cleaning	When enabled, the fan will periodically reverse automatically for dust cleaning.
External Fan Start Temperature Setting	When the device temperature reaches the set value, the external fan starts running.
Manual Fan Detection	Check if the fan can operate normally.
Silent Mode	
Silent Mode	<ul style="list-style-type: none"> • Enabling Silent Mode can reduce device noise. • Before enabling Silent Mode, please ensure the device is connected to a stable and reliable power grid; otherwise, it will not take effect. • After enabling Silent Mode, if the system's load power consumption is too high and the generated power cannot meet the demand, the system may automatically purchase power from the grid to ensure load operation. • During the use of Silent Mode, there may be some loss in photovoltaic power generation. • Supports setting Silent Mode time periods based on actual needs.

AC Side Settings Parameters

Parameter Name	Description
PV Connection Mode	<p>For some models, the photovoltaic string connection method for the inverter's MPPT ports can be manually configured to avoid misidentification of the connection method. Supported modes:</p> <ul style="list-style-type: none"> • Independent Connection: External photovoltaic strings are connected one-to-one with the inverter-side photovoltaic input ports. • Partial Parallel Connection: When one photovoltaic string is connected to multiple MPPT ports on the inverter side, other photovoltaic components are simultaneously connected to other MPPT ports on the inverter side. • Parallel Connection: When external photovoltaic strings are connected to the inverter-side photovoltaic input ports, multiple photovoltaic strings are first connected via a Y-cable and then split to connect to multiple photovoltaic input ports.
AC Port Connection Configuration	<p>Based on inverter port characteristics, supports connecting loads, generators, microgrid devices, etc. For details, please refer to 8.7.3.4. Multiport Parameters (Page 202).</p>

Parameter Name	Description
Backup Function Settings	<ul style="list-style-type: none"> • Backup: When enabled, if the grid fails, loads connected to the inverter's BACK-UP port can be powered by the battery, ensuring uninterrupted power supply. • Supports the following detection modes: <ul style="list-style-type: none"> ◦ UPS Mode - Full-wave Detection: Detects whether the grid voltage is too high or too low. ◦ UPS Mode - Half-wave Detection: Detects whether the grid voltage is too low. ◦ EPS Mode - Supports Low Voltage Ride-Through: Disables the grid voltage detection function. • Off-grid First Cold Start: Takes effect only once. After enabling, the battery or PV can be used to output backup power in off-grid mode. • Off-grid Cold Start Hold: Takes effect multiple times. After enabling, the battery or PV can be used to output backup power in off-grid mode. • Clear Overload Fault: When the load power connected to the inverter's BACK-UP port exceeds the rated load power, the inverter will restart and detect the load power again. If not handled promptly, the inverter will restart multiple times for load detection, with increasing intervals between each restart. After the BACK-UP port load power is reduced within the rated range, click this switch to clear the inverter restart interval, and the inverter will restart immediately.
Parallel Unit Management	When inverters are paralleled via RS485, the master or slave attribute of the inverter needs to be manually set, along with information such as the slave address.
Grid Type	Select single-phase, split-phase, or three-phase grid based on the actual grid type the inverter is adapted to.
Output Mode	Set according to the actual grid type the inverter is connected to. Currently supports three-phase three-wire and three-phase four-wire systems.

Parameter Name	Description
Three-Phase Unbalanced Output	For three-phase inverters connected to unbalanced loads, such as L1, L2, L3 connected to loads of different power, the three-phase unbalanced output function needs to be enabled.
Unbalanced Phase Voltage Function	When enabled, the inverter will perform power derating or power distribution based on each phase's grid voltage value to maximize power utilization.
Grid Connection Point Rated Current Protection	To prevent damage or tripping of the household circuit breaker due to excessive buy/sell current from the grid, set the grid connection point rated current to limit input and output current values.

PV Settings Parameters

Parameter Name	Description
PV Connection Mode	<p>For certain models, the PV string connection method for the inverter's MPPT ports can be manually configured to avoid misidentification of the connection method. Supported modes:</p> <ul style="list-style-type: none"> • Independent connection: External PV strings are connected one-to-one with the inverter-side PV input ports. • Partial parallel connection: When one PV string is connected to multiple MPPT ports on the inverter side, other PV modules are simultaneously connected to other MPPT ports on the inverter side. • Parallel connection: When external PV strings are connected to the inverter-side PV input ports, multiple PV strings are first connected via a Y-cable and then split into multiple branches connected to multiple PV input ports.

Parameter Name	Description
PID Settings	<ul style="list-style-type: none"> • During operation, a potential difference exists between the output electrodes of a PV panel and its grounded frame, which can lead to long-term degradation of the panel's power generation efficiency, known as Potential Induced Degradation (PID). • GoodWe products' PID function works by elevating the voltage difference between the PV panel and its frame to a positive value (referred to as positive bias elevation), achieving PID suppression. This is suitable for P-type panels and N-type panels that require positive bias elevation to suppress PID. For N-type panels that require negative bias reduction to suppress PID, it is recommended to disable this function. Please consult the module supplier to determine if an N-type module belongs to the type requiring positive bias elevation for PID suppression.
Shadow Scan Function	When PV panels are severely shaded, enabling the Shadow Scan function can optimize the inverter's power generation efficiency.

Battery Settings

Parameter Name	Description
Battery Activation	If you purchased an inactivated battery, you need to enter an activation code to activate the battery functions.
BAT Port Connection Configuration	Select the battery connection mode based on the actual connection status of the battery.

Protection Parameters

Parameter Name	Description
Electrical Protection	
Lightning Protection Alarm	When the lightning protection alarm function is enabled, an alarm will be triggered to indicate an abnormality if the lightning protection module malfunctions.
Arc Fault Detection	<ul style="list-style-type: none"> • When the arc fault detection function is enabled, it can monitor whether there is an arc hazard in the device. • Click "Arc Fault Self-Test" to start a self-test of the arc detection module and confirm if its status is normal. View the result via the "Arc Fault Detection Status". • If the inverter triggers an arc fault alarm less than 5 times within 24 hours, the alarm can be cleared automatically. After the 5th arc fault alarm, the inverter shuts down for protection. You must click "Clear Arc Fault Alarm" to clear the fault before the inverter can resume normal operation.
Backup N-PE Relay Switch	According to the grid standards of certain countries or regions, it is required to ensure the internal relay of the BACK-UP port remains closed during off-grid operation, thereby connecting the N and PE lines.
Grid/Grid-Tie Protection	
Islanding Protection	Enable or disable the islanding protection function as required.
NS Protection	Enable or disable the NS protection function according to the standards of certain countries or regions.
Safety Regulations	
Grid Standard Code	Select the grid standard code according to the country or region where the inverter is located.
Safety Parameter Settings	Safety parameters must be set according to the requirements of the grid company. Any changes require approval from the grid company.

General Settings Parameters

Parameter Name	Description
Device Self-Test	Initiates device status self-test.
Restore Factory Settings	Restores certain functions to factory state.

8.7.3.1 Custom Safety Parameters

Note

Safety compliance parameters must be set according to the grid company's requirements. Any changes must be approved by the grid company.

Active Power Mode

P(F) Curve

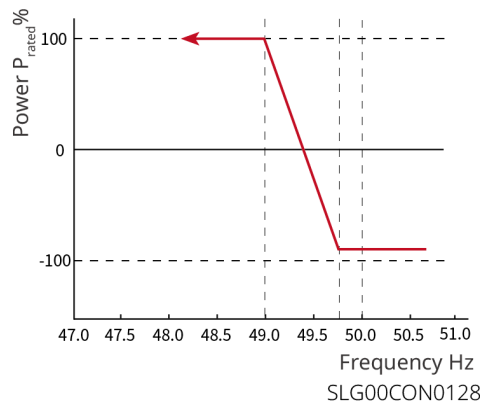
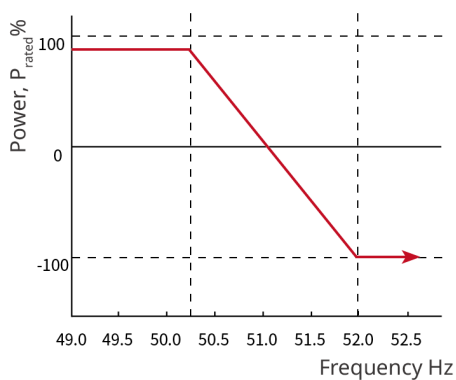

P(U) Curve

Parameter Name	Description
Output Active Power Setting	Sets the inverter output power limit.
Power Change Gradient	Sets the change slope for increasing or decreasing active output power.
Over-Frequency Power Reduction	

Parameter Name	Description
P(F) Curve	Enable this function when the P(F) curve needs to be configured according to grid standards in certain countries or regions.
Over-Frequency Reduction Mode	<p>Set the over-frequency reduction mode based on actual requirements.</p> <ul style="list-style-type: none"> • Slope Mode: Adjusts power based on the over-frequency point and reduction slope. • Stop Mode: Adjusts power based on the over-frequency start point and over-frequency end point.
Over-Frequency Start Point	When grid frequency is too high, the inverter reduces output active power. When grid frequency exceeds this value, the inverter output power begins to decrease.
Buy/Sell Power Conversion Frequency	When the set frequency value is reached, the system switches from selling power to buying power.
Over-Frequency End Point	When grid frequency is too high, the inverter reduces output active power. When grid frequency exceeds this value, the inverter output power does not continue to decrease.
Over-Frequency Power Slope Reference Power	Adjusts the inverter output active power based on rated power, current power, apparent power, or maximum active power.
Over-Frequency Power Slope	When grid frequency exceeds the over-frequency point, the inverter output power decreases according to the set slope.
Dead Time	The delay response time for inverter output power change when grid frequency exceeds the over-frequency point.
Hysteresis Function Enable	Enable the hysteresis function.

Parameter Name	Description
Frequency Hysteresis Point	During over-frequency reduction, if the frequency decreases, the power is output at the lowest point of the reduced power until the frequency falls below the hysteresis point, at which point power recovers.
Hysteresis Wait Time	For over-frequency reduction with decreasing frequency, when the frequency falls below the hysteresis point, this is the waiting time for power recovery; power will only recover after this wait time.
Hysteresis Power Recovery Slope Reference Power	For over-frequency reduction with decreasing frequency, when the frequency falls below the hysteresis point, this is the reference for power recovery, i.e., power recovers at the rate of (recovery slope * reference power). Supported: Pn (Rated Power), Ps (Apparent Power), Pm (Current Power), Pmax (Maximum Power), Power Difference (ΔP).
Hysteresis Power Recovery Slope	For over-frequency reduction with decreasing frequency, when the frequency falls below the hysteresis point, this is the power change slope during power recovery.
Under-Frequency Power Boost	
P(F) Curve	Enable this function when the P(F) curve needs to be configured according to grid standards in certain countries or regions.
Under-Frequency Boost Mode	Set the under-frequency boost mode based on actual requirements. <ul style="list-style-type: none"> • Slope Mode: Adjusts power based on the under-frequency point and boost slope. • Stop Mode: Adjusts power based on the under-frequency start point and under-frequency end point.
Under-Frequency Start Point	When grid frequency is too low, the inverter increases output active power. When grid frequency falls below this value, the inverter output power begins to increase.

Parameter Name	Description
Buy/Sell Power Conversion Frequency	When the set frequency value is reached, the system switches from selling power to buying power.
Under-Frequency End Point	When grid frequency is too low, the inverter increases output active power. When grid frequency falls below this value, the inverter output power does not continue to increase.
Over-Frequency Power Slope Reference Power	Adjusts the inverter output active power based on rated power, current power, apparent power, or maximum active power.
Under-Frequency Power Slope	When grid frequency is too low, the inverter increases output active power. This is the slope for the inverter output power increase.
Dead Time	The delay response time for inverter output power change when grid frequency falls below the under-frequency point.
Hysteresis Function Enable	Enable the hysteresis function.
Frequency Hysteresis Point	During under-frequency boost, if the frequency increases, the power is output at the lowest point of the boosted power until the frequency rises above the hysteresis point, at which point power recovers.
Hysteresis Wait Time	For under-frequency boost with increasing frequency, when the frequency rises above the hysteresis point, this is the waiting time for power recovery; power will only recover after this wait time.
Hysteresis Power Recovery Slope Reference Power	For under-frequency boost with increasing frequency, when the frequency rises above the hysteresis point, this is the reference for power recovery, i.e., power recovers at the rate of (recovery slope * reference power). Supported: P _n (Rated Power), P _s (Apparent Power), P _m (Current Power), P _{max} (Maximum Power), Power Difference (ΔP).

Parameter Name	Description
Hysteresis Power Recovery Slope	For under-frequency boost with increasing frequency, when the frequency rises above the hysteresis point, this is the power change slope during power recovery.
P(U) Curve Enable	Enable this function when the P(U) curve needs to be configured according to grid standards in certain countries or regions.
Vn Voltage	The ratio of the actual voltage value at the Vn point to the rated voltage, where n=1, 2, 3, 4. For example: setting it to 90 means: $V/V_{rated}\% = 90\%$.
Vn Active Power	The ratio of the inverter's output active power at the Vn point to the apparent power, where n=1, 2, 3, 4. For example: setting it to 48.5 means: $P/P_{rated}\% = 48.5\%$.
Output Response Mode	Set the active output response mode. Supported: <ul style="list-style-type: none"> • First-Order Low-Pass Filter: Within the response time constant, output adjustment follows a first-order low-pass curve. • Slope Scheduling: Output adjustment follows the set power change slope.
Power Change Gradient	When the output response mode is set to Slope Scheduling, active power scheduling is performed according to the power change gradient.
First-Order Low-Pass Filter Time Parameter	When the output response mode is set to First-Order Low-Pass Filter, this is the time constant for active power change according to the first-order low-pass filter curve.
Overload Function Switch	When turned on, the maximum active power output is 1.1 times the rated power; otherwise, the maximum active power output equals the rated power value.

Reactive Power Mode

Q(U) Curve

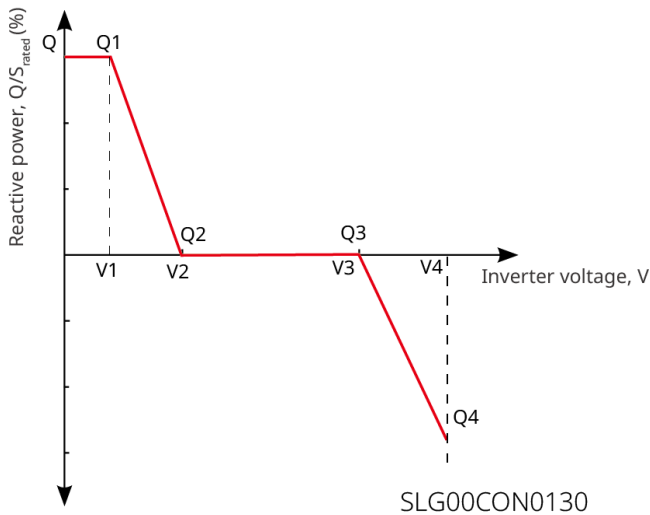

Cosφ Curve

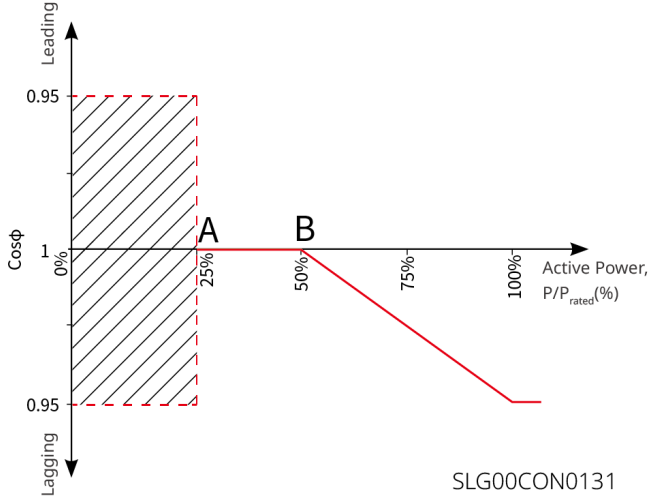

Parameter Name	Description
Fixed PF	
Fixed PF	Enable this function when a fixed PF value is required according to the grid standards of certain countries or regions. After the parameter is set successfully, the power factor remains unchanged during inverter operation.
Under-excitation	Set the power factor as positive or negative according to the grid standards of the country or region and actual usage requirements.
Over-excitation	
Power Factor	Set the power factor according to actual needs, with a range from -1 to -0.8 and +0.8 to +1.

Parameter Name	Description
Fixed Q	
Fixed Q	Enable this function when fixed reactive power is required according to the grid standards of certain countries or regions.
Over-excitation/Under-excitation	Set the reactive power as inductive or capacitive according to the grid standards of the country or region and actual usage requirements.
Reactive Power	Set the ratio of reactive power to apparent power.
Q(U) Curve	
Q(U) Curve	Enable this function when setting the Q(U) curve is required according to the grid standards of certain countries or regions.
Mode Selection	Set the Q(U) curve mode, supporting basic mode and slope mode.
Vn Voltage	The ratio of the actual voltage at point Vn to the rated voltage, where n=1, 2, 3, 4.
	For example: when set to 90, it means: $V/V_{rated}\% = 90\%$.
Vn Reactive Power	The ratio of the reactive power output by the inverter at point Vn to the apparent power, where n=1, 2, 3, 4.
	For example: when set to 48.5, it means: $Q/S_{rated}\% = 48.5\%$.
Voltage Deadband Width	Set the voltage deadband when the Q(U) curve mode is set to slope mode. Within the deadband range, there is no requirement for reactive power output.
Over-excitation Slope	Set the power change slope as positive or negative when the Q(U) curve mode is set to slope mode.
Under-excitation Slope	
Vn Reactive Power	The ratio of the reactive power output by the inverter at point Vn to the apparent power, where n=1, 2, 3, 4. For example: when set to 48.5, it means: $Q/S_{rated}\% = 48.5\%$.

Parameter Name	Description
Q(U) Curve Response Time Constant	The power must reach 95% within 3 response time constants according to a first-order low-pass curve.
Extended Function Enable	Enable the extended function and set the corresponding parameters.
Enter Curve Power	When the ratio of the inverter output reactive power to the rated power is between the enter curve power and exit curve power, it meets the Q(U) curve requirements.
Exit Curve Power	
cosφ(P) Curve	
cosφ(P) Curve	Select this function when setting the Cosφ curve is required according to the grid standards of certain countries or regions.
Mode Selection	Set the cosφ(P) curve mode, supporting basic mode and slope mode.
N Point Power	The percentage of inverter output active power to rated power at point N, where N=A, B, C, D, E.
N Point cosφ Value	Power factor at point N, where N=A, B, C, D, E.
Over-excitation Slope	Set the power change slope as positive or negative when the cosφ(P) curve mode is set to slope mode.
Under-excitation Slope	
n Point Power	The percentage of inverter output active power to rated power at point N, where N=A, B, C.
n Point cosφ Value	Power factor at point N, where N=A, B, C.
cosφ(P) Curve Response Time Constant	The power must reach 95% within 3 response time constants according to a first-order low-pass curve.
Extended Function Enable	Enable the extended function and set the corresponding parameters.

Parameter Name	Description
Enter Curve Voltage	When the grid voltage is between the enter curve voltage and exit curve voltage, it meets the Cosφ curve requirements.
Exit Curve Voltage	
Q(P) Curve	
Q(P) Curve Enable	Enable this function when setting the Q(P) curve is required according to the grid standards of certain countries or regions.
Mode Selection	Set the Q(P) curve mode, supporting basic mode and slope mode.
Pn Point Power	The ratio of reactive power at point Pn to rated power, where n=1, 2, 3, 4, 5, 6. For example: when set to 90, it means: $Q/Prated\% = 90\%$.
Pn Point Reactive Power	The ratio of active power at point Pn to rated power, where n=1, 2, 3, 4, 5, 6. For example: when set to 90, it means: $P/Prated\% = 90\%$.
Over-excitation Slope	Set the power change slope as positive or negative when the Q(P) curve mode is set to slope mode.
Under-excitation Slope	
Pn Point Power	The ratio of reactive power at point Pn to rated power, where n=1, 2, 3. For example: when set to 90, it means: $Q/Prated\% = 90\%$.
Pn Point Reactive Power	The ratio of active power at point Pn to rated power, where n=1, 2, 3. For example: when set to 90, it means: $P/Prated\% = 90\%$.
Response Time Constant	The power must reach 95% within 3 response time constants according to a first-order low-pass curve.

Grid Protection Parameters

Parameter Name	Description
Overvoltage Trigger Stage n Value	Set the grid overvoltage trigger Stage n protection point, n=1, 2, 3, 4.
Overvoltage Trigger Stage n Trip Time	Set the grid overvoltage trigger Stage n trip time, n=1, 2, 3, 4.
Undervoltage Trigger Stage n Value	Set the grid undervoltage trigger Stage n protection point, n=1, 2, 3, 4.
Undervoltage Trigger Stage n Trip Time	Set the grid undervoltage trigger Stage n trip time, n=1, 2, 3, 4.
10min Overvoltage Trigger Value	Set the 10-minute overvoltage trigger value.
10min Overvoltage Trip Time	Set the 10-minute overvoltage trigger trip time.
Overfrequency Trigger Stage n Value	Set the grid overfrequency trigger Stage n protection point, n=1, 2, 3, 4.
Overfrequency Trigger Stage n Trip Time	Set the grid overfrequency trigger Stage n trip time, n=1, 2, 3, 4.
Underfrequency Trigger Stage n Value	Set the grid underfrequency trigger Stage n protection point, n=1, 2, 3, 4.
Underfrequency Trigger Stage n Trip Time	Set the grid underfrequency trigger Stage n trip time, n=1, 2, 3, 4.

Grid Connection Parameters

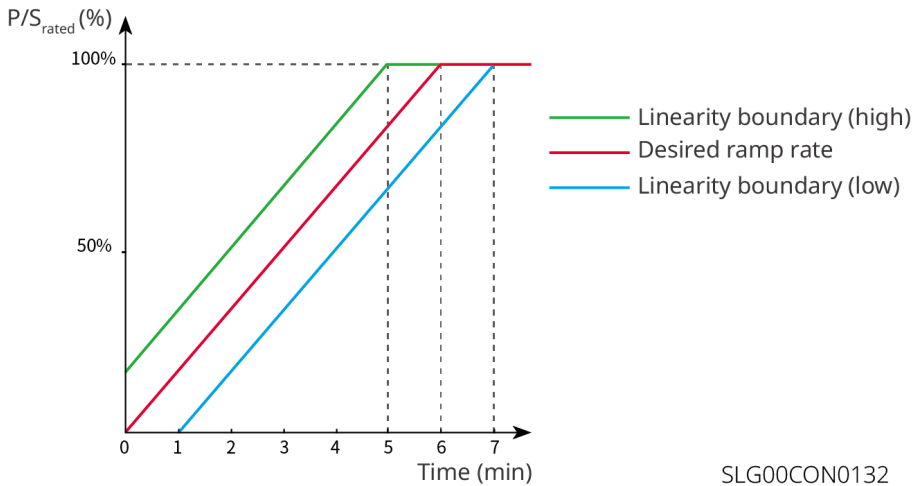

Parameter Name	Description
Startup and Grid Connection	
Connection Voltage Upper Limit	When the inverter connects to the grid for the first time, if the grid voltage is higher than this value, the inverter will be unable to connect to the grid.
Connection Voltage Lower Limit	When the inverter connects to the grid for the first time, if the grid voltage is lower than this value, the inverter will be unable to connect to the grid.
Connection Frequency Upper Limit	When the inverter connects to the grid for the first time, if the grid frequency is higher than this value, the inverter will be unable to connect to the grid.
Connection Frequency Lower Limit	When the inverter connects to the grid for the first time, if the grid frequency is lower than this value, the inverter will be unable to connect to the grid.
Grid Connection Wait Time	When the inverter connects to the grid for the first time, the waiting time before connecting to the grid after the grid voltage and frequency meet the connection requirements.
Startup Loading Slope Enable	Enable the startup slope function.
Startup Loading Slope	According to the standard requirements of certain countries or regions, the percentage of power increment outputtable per minute when the inverter starts up for the first time.

Parameter Name	Description
Fault Reconnection	
Connection Voltage Upper Limit	When the inverter reconnects to the grid after a fault, if the grid voltage is higher than this value, the inverter will be unable to connect to the grid.
Connection Voltage Lower Limit	When the inverter reconnects to the grid after a fault, if the grid voltage is lower than this value, the inverter will be unable to connect to the grid.
Connection Frequency Upper Limit	When the inverter reconnects to the grid after a fault, if the grid frequency is higher than this value, the inverter will be unable to connect to the grid.
Connection Frequency Lower Limit	When the inverter reconnects to the grid after a fault, if the grid frequency is lower than this value, the inverter will be unable to connect to the grid.
Grid Connection Wait Time	When the inverter reconnects to the grid after a fault, the waiting time before connecting to the grid after the grid voltage and frequency meet the connection requirements.
Reconnection Loading Slope Enable	Enable the reconnection slope function.
Reconnection Loading Slope	According to the standard requirements of certain countries or regions, the percentage of power increment outputtable per minute when the inverter connects to the grid (not for the first time). For example: When set to 10, it means the reconnection loading slope is: $10\%P/S_{rated}/\text{min}$.

Voltage Fault Ride-Through Parameters

Parameter Name	Description
Low Voltage Ride Through (LVRT)	

Parameter Name	Description
UVn Point Voltage	The ratio of the ride-through voltage at the LVRT characteristic point to the rated voltage during the low voltage ride-through process. n=1, 2, 3, 4, 5, 6, 7.
UVn Point Time	The ride-through time at the LVRT characteristic point during the low voltage ride-through process. n=1, 2, 3, 4, 5, 6, 7.
LVRT Entry Threshold	When the grid voltage is between the LVRT entry threshold and the LVRT exit threshold, the inverter does not immediately disconnect from the grid.
LVRT Exit Threshold	
Slope K1	The K coefficient for reactive power support during the low voltage ride-through process.
Zero Current Mode Enable	When enabled, the system outputs zero current during the low voltage ride-through process.
Entry Threshold	Threshold for entering zero current mode.
High Voltage Ride Through (HVRT)	
OVn Point Voltage	The ratio of the ride-through voltage at the HVRT characteristic point to the rated voltage during the high voltage ride-through process. n=1, 2, 3, 4, 5, 6, 7.
OVn Point Time	The ride-through time at the HVRT characteristic point during the high voltage ride-through process. n=1, 2, 3, 4, 5, 6, 7.
HVRT Entry Threshold	When the grid voltage is between the HVRT entry threshold and the HVRT exit threshold, the inverter does not immediately disconnect from the grid.
HVRT Exit Threshold	
Slope K2	The K coefficient for reactive power support during the high voltage ride-through process.
Zero Current Mode Enable	During the high voltage ride-through process, the system outputs zero current.
Entry Threshold	Threshold for entering zero current mode.

Frequency Fault Ride-Through Parameters

Parameter Name	Description
Frequency Ride-Through Enable	Enable the frequency ride-through function.
UFn Point Frequency	Set the frequency for under-frequency point n. n=1, 2, 3.
UFn Point Time	Set the under-frequency time for under-frequency point n. n=1, 2, 3.
OFn Point Frequency	Set the frequency for over-frequency point n. n=1, 2, 3.
OFn Point Time	Set the over-frequency time for over-frequency point n. n=1, 2, 3.

8.7.3.2 Grid Connection Power Scheduling Parameters

Grid Connection Power Limit (General)

Parameter Name	Description
Grid Connection Power Limitation	Enable this function when it is necessary to limit the output power according to the grid standards of certain countries or regions.
Power Limit	Set this based on the actual maximum power that can be fed into the grid.

Grid Connection Power Limit (Australia)

Parameter Name	Description
Software Grid-Connected Power Limitation	Enable this function when it is necessary to limit the output power according to the grid standards of certain countries or regions.

Parameter Name	Description
Power Limit	<ul style="list-style-type: none"> • Set based on the actual maximum power that can be fed into the grid. • Supports setting a fixed power value or a percentage. The set percentage is the ratio of the limited power to the inverter's rated power. • After setting a fixed value, the percentage changes automatically; after setting a percentage, the fixed value changes automatically.
Hardware Grid-Connected Power Limitation	After enabling this function, the inverter will automatically disconnect from the grid when the power fed into the grid exceeds the limit.

Grid Connection Power Limit (UK)

Parameter Name	Description
Grid-Connected Power Limit	Enable this function when it is necessary to limit the output power according to the grid standards of certain countries or regions.
Mode Selection	<ul style="list-style-type: none"> • Some models require selecting the current limiting mode. Supported modes: Per-Phase Current, Total Current. • When set to Per-Phase Current, the current of each phase is limited; when set to Total Current, the total three-phase current is limited.
Current Limit	Set this value based on the actual maximum current that can be input to the grid.

Grid Connection Power Limit (Brazil)

In regions like Brazil, users are allowed to set different power limits for different time periods to meet grid requirements.

Please download the template as prompted by the interface and configure the power limit information for different time periods. Once the template is filled out, upload it to the App to complete the time-of-use power limit setup.

Power Scheduling

Parameter Name	Description
Active Power Scheduling	
Active Scheduling Mode	<p>Controls the active power according to the selected scheduling mode, as required by the grid company in the inverter's country/region. Supports:</p> <ul style="list-style-type: none">• Disabled: Do not enable active power scheduling.• Active Power (W): Schedule according to a fixed value.• Active Power (%Pn): Schedule according to the percentage of active power to rated power.
Reactive Power Scheduling	
Reactive Scheduling Mode	<p>Controls the reactive power according to the selected scheduling mode, as required by the grid company in the inverter's country/region. Supports:</p> <ul style="list-style-type: none">• Disabled: Do not enable reactive power scheduling.• Reactive Power (Var): Schedule according to a fixed value.• Reactive Power (%Pn): Schedule according to the percentage of reactive power to rated power.• PF Compensation.
Nighttime Reactive Power	
Nighttime Reactive Enable	Enable the nighttime reactive power function.

Parameter Name	Description
Nighttime Reactive Scheduling Mode	<p>Controls the nighttime reactive power according to the selected scheduling mode, as required by the grid company in the inverter's country/region. Supports:</p> <ul style="list-style-type: none"> • Disabled: Do not enable reactive power scheduling. • Nighttime Reactive Scheduling (Var): Schedule according to a fixed value. • Nighttime Reactive Scheduling (%Pn): Schedule according to the percentage of reactive power to rated power.

Power Scheduling Response Parameters

Parameter Name	Description
Active Power Dispatch Response Mode	<p>Achieves the active power dispatch value through a dispatch response method, supporting:</p> <ul style="list-style-type: none"> • First-order low-pass filter, i.e., achieving active power dispatch according to a first-order low-pass curve within the response time constant, and setting the time constant for when the active power changes according to the first-order low-pass filter curve. • Slope mode, i.e., achieving active power dispatch according to the power change slope, and setting the active power dispatch change slope.

Parameter Name	Description
Reactive Power Dispatch Response Mode	<p>Achieves the reactive power dispatch value through a dispatch response method, supporting:</p> <ul style="list-style-type: none"> • First-order low-pass filter, i.e., achieving reactive power dispatch according to a first-order low-pass curve within the response time constant, and setting the time constant for when the reactive power changes according to the first-order low-pass filter curve. • Slope mode, i.e., achieving reactive power dispatch according to the power change slope, and setting the reactive power dispatch change slope.

8.7.3.3 Grid Remote Dispatch Parameters

According to the grid standard requirements of certain countries or regions, it is necessary to connect third-party dispatch equipment to realize the remote dispatch function for the photovoltaic system.

- Remote Shutdown: Realize the remote shutdown function through the signal control port. When an unexpected event occurs, the equipment can be controlled to stop working.
- DRED (Demand Response Enabling Device): Control the equipment through the DRED signal control port to meet the DRED certification requirements in regions such as Australia.
- RCR (Ripple Control Receiver): Control the equipment through the RCR signal control port to meet the grid dispatch requirements in regions such as Germany.
- EnWG (Energy Industry Act) 14a: All controllable loads must accept emergency dimming from the grid. The grid operator can temporarily reduce the maximum grid power purchase capacity of controllable loads to 4.2kW.

8.7.3.4 Reuse Port Parameters

Load Control Parameters

When the inverter supports the load control function, the load can be controlled via the App.

For the ET40-50kW series inverters, the load control function is only supported when the inverter is used with an STS. The inverter supports load control for the

GENERATOR port or the BACKUP LOAD port.

- Dry Contact Mode: When the switch status is set to ON, power supply to the load starts; when the switch status is set to OFF, power supply to the load stops. Please set the switch status to ON or OFF according to actual needs.
- Time Mode: The load will automatically be powered on or off within the set time period. Standard Mode or Smart Mode can be selected.

Parameter Name	Description
Standard Mode	Supplies power to the load within the set time period.
Smart Mode	Within the set time period, starts supplying power to the load when the surplus energy generated by photovoltaics exceeds the preset load rated power.
Start Time	The time mode will be active during the period between the start time and the stop time.
Stop Time	
Repeat	Set the repetition frequency.
Load Minimum Runtime	Applies only to Smart Mode. The minimum operating time for the load once it is turned on, to avoid frequent switching due to energy fluctuations.
Load Rated Power	Applies only to Smart Mode. Starts supplying power to the load when the surplus energy generated by photovoltaics exceeds this load rated power.

- SOC Mode: The inverter has a built-in relay dry contact control port (for ET40-50kW series inverters, this is the STS built-in control port) that can control whether to supply power to the load. In off-grid mode, if overload on the BACK-UP port or GENERATOR port is detected, or if the battery SOC protection function is triggered, power supply to the load connected to the port can be stopped.

Generator Control Parameters

When the inverter supports the generator control function, the generator can be controlled via the App.

For the ET40-50kW series inverters, generator connection and control are only supported when the inverter is used with an STS.

For the ET50-100kW series inverters, generator connection and control are only supported when the inverter is used with an STS.

- No Generator Connected: When no generator is connected to the energy storage system, please select 'No Generator Connected'.
- Manually Control Generator (Dry Contact Connection Not Supported): The generator start/stop needs to be controlled manually; the inverter cannot control the generator start/stop.
- Automatically Control Generator (Dry Contact Connection Supported): When the generator has a dry contact control port and is connected to the inverter, set the inverter's generator control mode in the App to Switch Control Mode or Auto Control Mode.
 - Switch Control Mode: When the switch status is turned ON, the generator works; the generator can automatically stop after running for the set operation time.
 - Auto Control Mode: Generator operation is prohibited during the set prohibited operation time period, and the generator operates during the set operation time period.

Parameter Name	Description
Dry Contact Control Mode	Switch Control Mode / Automatic Control Mode.
Switch Control Mode	
Generator Dry Contact Switch	Applicable only in Switch Control Mode.
Runtime	Generator continuous operation time. The generator stops running after the set time is reached.
Automatic Control Mode	
Prohibited Operation Period	Set the time period when generator operation is prohibited.
Runtime	The continuous operation time after the generator starts. The generator stops running after the set time is reached. If the generator's scheduled runtime includes a Prohibited Operation Period, the generator will stop during that period. After the Prohibited Operation Period ends, the generator restarts operation and the timer resets.

Parameter Name	Description
Generator Information Settings	
Rated Power	Set the rated operating power of the generator.
Operating Time	Set the continuous operating time of the generator. The generator will be shut down after this duration.
Voltage Upper Limit	Set the operating voltage range for the generator.
Voltage Lower Limit	
Frequency Upper Limit	Set the operating frequency range for the generator.
Frequency Lower Limit	
Warm-up Time	Set the no-load warm-up time for the generator.
Generator Battery Charging Settings	
Switch	Select whether to use the generator to charge the battery.
Max Charging Power (%)	The charging power when the generator charges the battery.
Start Charging SOC	When connected to a lithium battery, set the SOC threshold to start the generator. The generator starts to charge the battery when the battery SOC is below this value.
Stop Charging SOC	When connected to a lithium battery, set the SOC threshold to stop the generator. The generator stops charging the battery when the battery SOC is above this value.
Start Charging Voltage	When connected to a lead-acid battery, set the voltage threshold to start the generator. The generator starts to charge the battery when the battery voltage is below this value.
Stop Charging Voltage	When connected to a lead-acid battery, set the voltage threshold to stop the generator. The generator stops charging the battery when the battery voltage is above this value.

Microgrid Control Parameters

Parameter Name	Description
Battery Charge Max SOC	When the battery type is lithium battery, set the upper limit for charging SOC. Charging stops once this limit is reached.
Battery Charge Max Voltage	When the battery type is lead-acid battery, set the upper limit for charging voltage. Charging stops once this limit is reached.
Microgrid Forced Start Charging	<ul style="list-style-type: none"> • During a grid fault, if the battery level is too low to support the energy storage inverter's off-grid operation. Clicking this button forces the energy storage inverter to output voltage to the grid-tied inverter, thereby starting the grid-tied inverter. • Effective for a single instance.
Hourly Trigger	<ul style="list-style-type: none"> • During a grid fault, if the battery level is too low to support the energy storage inverter's off-grid operation. After enabling this function, the system will force the energy storage inverter to output voltage to the grid-tied inverter at a fixed time, thereby starting the grid-tied inverter. • Effective for multiple instances.
Grid Power Limit Offset Value	Sets the adjustable range for the maximum power the device can actually draw from the grid.

8.7.4 Battery Parameters

Parameter Settings - Information Configuration

Select the battery model based on the actual connected battery type.

Parameter Settings - Lead-Acid Settings

When connecting lead-acid batteries, set the lead-acid battery parameters.

Parameter Name	Description
Battery Parameters	

Parameter Name	Description
BMS Battery Capacity	Set the battery capacity according to the actual parameters.
BMS Battery Internal Resistance	Set the battery internal resistance according to the actual parameters.
BM Temperature Compensation	<ul style="list-style-type: none"> When the battery temperature changes, the battery charging voltage is affected. Using 25°C as the baseline, for every degree of temperature change, the charging voltage upper limit is adjusted according to the set value. For example, if the charging temperature influence coefficient is set to 10, when the battery temperature rises to 26 degrees, the charging voltage upper limit decreases by 10mV.
Discharge Parameters	
Discharge Parameters	Set the parameters for battery discharge according to actual requirements.
Charging Parameters	
Constant Charge Voltage	Set the voltage value for battery constant charging according to actual requirements.
Float Charge Voltage	Set the voltage value for battery float charging according to actual requirements.
Float Charge Current	The maximum charging current after the battery charging mode switches from constant/equalizing charge to float charge.
Time to Switch to Float Charge	The duration required for the battery charging mode to switch from constant/equalizing charge to float charge.
Equalizing Charge Cycle	Set the interval in days for battery equalizing charge.

Parameter Settings - Lithium Battery Settings

When connecting lithium batteries, set the lithium battery parameters.

Parameter Name	Description
Maximum Charging Current	Applicable to some models. Set the maximum charging current for the battery according to actual requirements.
Maximum Discharging Current	Applicable to some models. Set the maximum discharging current for the battery according to actual requirements.
Battery Heating	<ul style="list-style-type: none"> • Optional. This option appears on the interface when a battery supporting the heating function is connected. After enabling the battery heating function, PV generation or grid power will be used to heat the battery when the battery temperature does not support startup. • The temperature thresholds for heating modes vary by battery model. Please refer to the actual specifications. • Enabling the battery heating function consumes a portion of system power. The battery heating function defaults to low-power mode upon activation and can be switched to other power modes if needed. • The start and stop of the battery heating function are automatically controlled by the BMS based on ambient temperature. Therefore, the installation environment and location of the device will affect the activation and deactivation of the heating function. • Supports setting heating time periods according to actual needs. However, within the set time periods, the heating function's activation is still automatically controlled by ambient temperature. • If PV and AC power only meet the load demand and the battery power is insufficient for self-heating, the heating function cannot be activated.
Battery Wake-up	<ul style="list-style-type: none"> • When enabled, the battery can be woken up after it shuts down due to undervoltage protection. • Only applicable to lithium batteries without circuit breakers. When enabled, the output voltage at the battery port is approximately 60V.

Parameter Name	Description
Breathing Light	<ul style="list-style-type: none"> • Only applicable to ESA 3-10kW series inverters. • Set the breathing light flashing duration. Supported options: Always On, Always Off, 3min. • The default mode is to light up for three minutes after power-on and then automatically turn off.

Protection Parameters - Limit Protection

Parameter Name	Description
SOC Upper Limit	The upper limit for battery charging. Charging stops when the battery SOC reaches this upper limit.
SOC Protection	When enabled, the battery protection function can be activated if the battery capacity falls below the set Depth of Discharge.
Grid-tied DOD	The maximum allowable discharge depth for the battery when the inverter is operating in grid-tied mode.
Off-grid DOD	The maximum allowable discharge depth for the battery when the inverter is operating in off-grid mode.
Backup Power SOC Maintenance	To ensure sufficient battery SOC for normal system operation during off-grid periods, the system will charge the battery from the grid to the set SOC protection value while operating in grid-tied mode.
Off-grid Recovery SOC	When the inverter operates off-grid, if the battery SOC drops to the SOC lower limit, the inverter stops output and only charges the battery until the SOC recovers to the Off-grid Recovery SOC value. If the SOC lower limit is higher than the Off-grid Recovery SOC, charging will continue until SOC lower limit + 10%.

Battery Charging Parameters

Parameter Name	Description
Battery Immediate Charge	When enabled, the battery is charged immediately from the grid. Takes effect only once.
Stop Charging SOC	When the battery SOC reaches the immediate charge SOC upper limit, battery charging will stop.
Battery Immediate Charge Power	The percentage of the charging power relative to the inverter's rated power when Battery Immediate Charge starts. For example, for a 10kW rated inverter, setting it to 60 results in a 6kW charging power.
Start	Start charging immediately.
Stop	Stop the current charging task immediately.

8.7.5 Electricity Meter Parameters

Parameter Name	Description
Meter Binding	<ul style="list-style-type: none"> When both grid-tied inverters and energy storage inverters are used simultaneously in a photovoltaic system to achieve coupling or microgrid functions, dual meters may be employed in the system. Please configure the meter binding information according to the actual usage scenario. Applicable only to GoodWe meters.
Meter/CT Auxiliary Detection	Using this function allows you to detect whether the meter CT is correctly connected and its current operating status.
External Meter CT Ratio	Set the ratio between the primary side and secondary side currents of the externally connected meter CT.

8.7.6 Smart Communication Stick Parameters

Note

The communication configuration interface may vary depending on the communication module connected to the inverter. Please refer to the actual interface.

Communication Parameters

Parameter Name	Description
WLAN/LAN	
WLAN Control	Default is off. When this function is enabled, the App can connect to the device via WLAN if they are on the same local network. Otherwise, connection is unavailable even on the same network.
Modbus TCP	When enabled, third-party platforms can access the inverter via the ModbusTCP protocol to achieve monitoring functionality.
LAN	Automatically identifies the LAN network the device is connected to.
WLAN	Select the WiFi network the device connects to based on the actual situation, enabling communication between the device and the router or switch.
4G	
APN Settings	<ul style="list-style-type: none">• APN settings are only applicable for configuring the SIM card information of 4G communication devices.• If the 4G module does not provide a Bluetooth signal, first configure the APN parameters via the Bluetooth module or WiFi module to enable 4G communication.
Bluetooth	
Bluetooth Always On	Default is off. When this function is enabled, the device's Bluetooth remains continuously on, maintaining connection with the App. Otherwise, the device's Bluetooth will turn off after 5 minutes, disconnecting from the App.

Password

Supports modifying the password for logging into the App during local connection. When connected locally via WiFi, supports modifying the hotspot password of the WiFi communication stick.

Control/Enable Parameters

Parameter Name	Description
FTP	When this function is enabled, system operation data can be uploaded to a specified server via the FTP protocol, enabling remote monitoring functionality.
Remote Maintenance	When this function is enabled, remote maintenance of the device is supported, such as remote upgrades.
Restore Factory Settings	Restores the smart communication stick to its factory settings, including passwords, network configuration information, etc.

8.7.7 Household Energy Management Device Parameters

Note

Please set parameters according to local laws, regulations, and grid standards.

Grid Control Parameters

Sequence No.	Parameter Name	Description
1	Enable/Disable	Enable this function when output power needs to be limited according to grid standards in certain countries or regions.
2	Anti-Reverse Flow	Set the maximum power the device can actually feed into the grid according to requirements in certain countries or regions.

Sequence No.	Parameter Name	Description
3	Limitation Method	<p>Select the method for controlling the device's output power based on actual conditions.</p> <ul style="list-style-type: none"> • Total Power: Controls the total power at the point of common coupling not to exceed the output power limit. • Single-Phase Power: Controls the power of each phase at the point of common coupling not to exceed the output power limit.
4	Grid Power Limit Offset	<p>Sets the adjustable range for the maximum power the device can actually feed into the grid.</p> <p>Maximum power delivered to the grid = Maximum grid feed-in power + Maximum grid feed-in power offset.</p>
5	Reverse Flow Protection Action	<p>When reverse flow occurs in the system and exceeds the maximum protection time (default 5s), the following protective measures can be taken:</p> <ul style="list-style-type: none"> • Power Limitation: The device continues to operate at a percentage of its rated power. • Device disconnects from the grid.
6	Reverse Flow Protection Power Limit	<p>The device continues to operate at a percentage of its rated power.</p>
7	Meter Communication Exception Handling	<p>Enable this function to take protective measures when communication between the meter and the device is abnormal.</p>

Sequence No.	Parameter Name	Description
8	Meter Exception Handling Method	<p>When a meter communication exception occurs in the system, the following protective measures can be taken:</p> <ul style="list-style-type: none"> • Power Limitation: The device continues to operate at a percentage of its rated power. • Device disconnects from the grid.
9	Meter Handling Power Limit	The device continues to operate at a percentage of its rated power.

Power Control Parameters

Serial Number	Parameter Name	Description
<p>RCR: According to standard requirements in regions such as Germany, the device must provide RCR (Ripple Control Receiver) signal control ports to meet grid dispatch demands.</p>		
1	RCR	Enable or disable the RCR function.
2	Active Power Dispatch	<ul style="list-style-type: none"> • Select one or more DI ports based on the grid company's requirements and the type of RCR fixture, and set the corresponding percentage. The percentage refers to the system output power as a percentage of the rated power. • Supports configuration of 16 levels of percentage values. Please set according to the actual requirements of the grid company. • Do not set duplicate state combinations for DI1-DI4, otherwise the function cannot execute properly. • If the actual wiring of the connected DI ports does not match the set values, the operating status will not take effect.

Serial Number	Parameter Name	Description
3	Reactive Power Dispatch	<ul style="list-style-type: none"> • Select one or more DI ports based on the grid company's requirements and the type of RCR fixture, and set the corresponding PF value. • Supports configuration of 16 levels of power factor values. Please set according to the actual requirements of the grid company. • PF value range requirement: [-100, -80] or [80, 100]. [-100, -80] corresponds to a lagging power factor of [-0.99, -0.8], [80, 100] corresponds to a leading power factor of [0.8, 1]. • Do not set duplicate state combinations for DI1-DI4, otherwise the function cannot execute properly. • If the actual wiring of the connected DI ports does not match the set values, the operating status will not take effect.
<p>RCR&EnWG 14a:</p> <ul style="list-style-type: none"> • According to standard requirements in regions such as Germany, the device must provide RCR (Ripple Control Receiver) signal control ports to meet grid dispatch demands. • For regions subject to the EnWG 14a regulation, all controllable loads must accept emergency dimming from the grid. Grid operators can temporarily reduce the maximum grid purchase power of controllable loads to 4.2kW. 		
4	RCR&EnWG 14a	Enable or disable the RCR&EnWG 14a function.
5	Grid Purchase Power Limit	Set the upper limit for power purchased from the grid according to local grid regulation requirements.

Serial Number	Parameter Name	Description
6	Active Power Dispatch	<ul style="list-style-type: none"> • The DI4 port is fixed for use with EnWG 14a. • Select one or more DI ports based on the grid company's requirements and the type of RCR fixture, and set the corresponding percentage. The percentage refers to the system output power as a percentage of the rated power. • Supports configuration of 8 levels of percentage values. Please set according to the actual requirements of the grid company. • Do not set duplicate state combinations for DI1-DI3, otherwise the function cannot execute properly. • If the actual wiring of the connected DI ports does not match the set values, the operating status will not take effect.
7	Reactive Power Dispatch	<ul style="list-style-type: none"> • The DI4 port is fixed for use with EnWG 14a. • Select one or more DI ports based on the grid company's requirements and the type of RCR fixture, and set the corresponding PF value. • Supports configuration of 8 levels of power factor values. Please set according to the actual requirements of the grid company. • PF value range requirement: [-100, -80] or [80, 100]. [-100, -80] corresponds to a lagging power factor of [-0.99, -0.8], [80, 100] corresponds to a leading power factor of [0.8, 1]. • Do not set duplicate state combinations for DI1-DI3, otherwise the function cannot execute properly. • If the actual wiring of the connected DI ports does not match the set values, the operating status will not take effect.

Serial Number	Parameter Name	Description
Remote Shutdown: According to requirements in certain countries or regions, the device must provide a remote shutdown function to control the device to stop working in emergency situations.		
8	Remote Shutdown	Enable or disable the remote shutdown function.
9	Immediately Restore Grid Connection	If you need to restore the grid-connected state after the device is shut down, please first manually power on the device, then click 'Immediately Restore Grid Connection'.

Other Parameters

No.	Parameter Name	Description
Electricity Meter Settings		
1	Select Meter	Select the actual connected electricity meter model.
2	Wiring Mode	Set the wiring method of the meter. Supports: <ul style="list-style-type: none"> • Single-phase single-wire • Three-phase three-wire • Three-phase four-wire
3	CT Ratio	<ul style="list-style-type: none"> • Set when the meter model is GM330. • Set the CT ratio value of the meter.
Antenna Settings		
4	Select Antenna	Select the built-in antenna or external antenna based on the actual situation.
Time Settings		

No.	Parameter Name	Description
5	Network Time Sync	After enabling, select the time server to perform time synchronization based on the chosen time source.
6	Time Server	Set the time server. Supports: <ul style="list-style-type: none"> • time.google.com • pool.ntp.org • ntp.aliyun.com

Export Logs

Supports exporting device operation logs. Before exporting logs, please ensure the HEMS and the phone are connected to the same router.

8.7.8 Operation and Maintenance Parameters

Parameter Name	Description
Firmware Upgrade	<ul style="list-style-type: none"> • Supports viewing or upgrading software versions such as the inverter's DSP version, ARM version, BMS version, AFCI version, STS version, communication module, etc. • Some devices do not support upgrading software versions via the App. Please refer to the actual device for details.
Log Export	<ul style="list-style-type: none"> • Supports exporting, downloading, and sharing logs. • Supports exporting different types of logs, such as communication module logs, inverter logs, etc. • Some models support exporting safety parameter files after selecting the safety regulation country.
Grid	

Parameter Name	Description
Auto Test	Turn on this function when it is necessary to set up grid connection auto-test according to the grid standards of certain countries or regions.

9 System Maintenance

9.1 System Power-Off

Danger

- When performing operation and maintenance on equipment within the system, please power down the system. Operating equipment while energized may cause equipment damage or risk of electric shock.
- After the equipment is powered off, internal components require a certain amount of time to discharge. Please wait according to the time indicated on the label until the equipment is completely discharged.
- Restarting the battery should be performed using the air switch power-on method.
- When shutting down the battery system, please strictly adhere to the battery system power-down requirements to prevent damage to the battery system.
- When there are multiple batteries in the system, powering down any one battery will power down all batteries.

Note

- The circuit breakers between the inverter and the battery, and between battery systems, must be installed according to local laws and regulations.
- To ensure effective protection of the battery system, the cover plate of the battery system switch should remain closed, and the protective cover should automatically close after being opened. If the battery system switch is not used for a long time, it must be secured with screws.

Power-Off Procedure

1. Disconnect the BACK-UP circuit breaker.
2. Disconnect the generator/heavy load switch.
3. Disconnect the ON-GRID circuit breaker.
4. (Select according to local regulations) Disconnect the switch between the inverter

and the battery.

5. Disconnect the battery system switch.

6. Disconnect the circuit breaker between the PV components and the inverter.

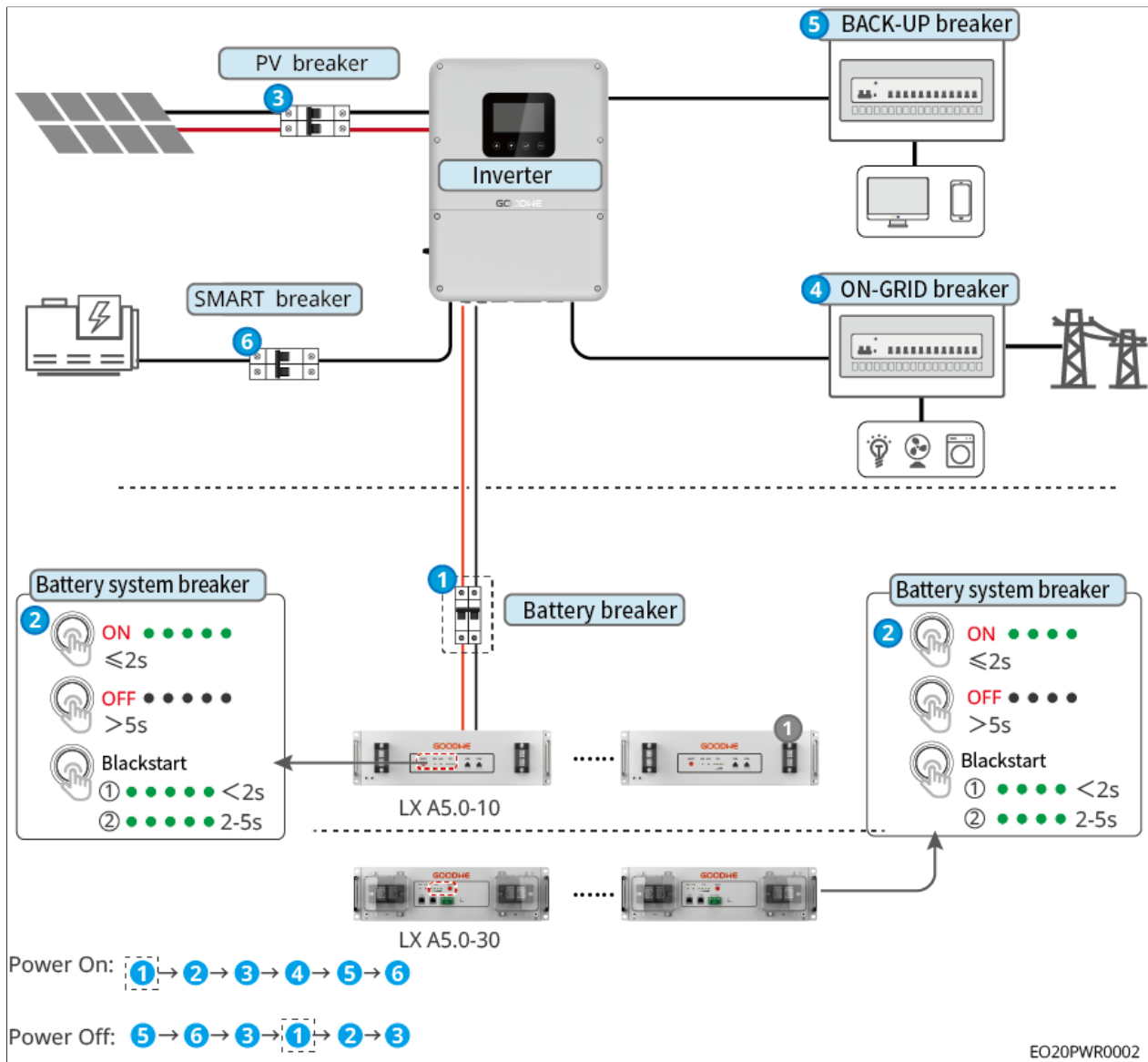

9.2 Equipment Removal



- Ensure the device is powered off.
- Wear personal protective equipment when operating the device.
- Use proper disassembly tools when removing wiring terminals to avoid damaging the terminals or the device.
- Unless otherwise specified, the device disassembly sequence is the reverse of the installation sequence. This document will not reiterate these steps.

1. Power down the system.
2. Label the cables connected to the system to indicate the cable type.
3. Disconnect the cables from the inverter, battery, smart meter, and other components in the system, such as DC cables, AC cables, communication cables, and protective ground cables.
4. Remove devices such as the smart communication stick, inverter, battery, and smart meter.
5. Store the equipment properly. If it will be put into use again later, ensure the storage conditions meet the requirements.

9.3 Equipment Decommissioning

When equipment can no longer be used and needs to be decommissioned, please dispose of it according to the electrical waste disposal requirements of the regulations in the country/region where the equipment is located. Do not dispose of the equipment as general household waste.

9.4 Regular Maintenance



- If any issues are found that may affect the battery or energy storage inverter system, contact after-sales personnel. Disassembly by unauthorized personnel is prohibited.
- If exposed copper wires are found inside the conductive cables, do not touch them. High voltage hazard. Contact after-sales personnel. Disassembly by unauthorized personnel is prohibited.
- In case of any other emergencies, contact after-sales personnel immediately. Operate under the guidance of after-sales personnel or wait for them to perform on-site operations.

Maintenance Items	Maintenance Methods	Maintenance Cycle	Maintenance Purpose
System Cleaning	Check for foreign objects or dust on heat sinks, fans, and air intake/outlet vents. Check if the installation space meets requirements and if there is any clutter accumulation around the equipment.	Once every six months	Prevent cooling failures.
System Installation	Check if the equipment installation is secure and if fastening screws are loose. Check for any damage or deformation on the equipment's exterior.	Once every six months to once a year	Confirm equipment installation stability.
Electrical Connections	Check for loose electrical connections, damaged cable exteriors, or exposed copper wires.	Once every six months to once a year	Confirm electrical connection reliability.
Sealing	Check if the sealing of the equipment's cable entry holes meets requirements. If gaps are too large or unsealed, reseal them.	Once a year	Confirm machine sealing and intact waterproof performance.

Maintenance Items	Maintenance Methods	Maintenance Cycle	Maintenance Purpose
Battery Maintenance	If the battery has not been used or fully charged for an extended period, it is recommended to charge it regularly.	Once every 15 days	Protect battery service life.

9.5 Fault

9.5.1 View Fault/Alarm Details

All detailed fault and alarm information for the energy storage system is displayed in the **SEMS+ App and SEMS+ WEB**. If your product experiences an abnormality and you do not see related fault information in the **SEMS+ App or SEMS+ WEB**, please contact the after-sales service center.

- In SEMS+ App

1. Open the SEMS+ App and log in with any account.
2. On the homepage, click "Alarm" to view the alarm information for all power plants under the account.

- SEMS+ WEB

1. Open the SEMS+ WEB and log in with any account.
2. On the power plant details page, click "Alarm" to view all alarm information for the current power plant.

9.5.2 Fault Information and Handling Methods

Please perform troubleshooting according to the following methods. If the troubleshooting methods cannot help you, please contact the after-sales service center.

When contacting the after-sales service center, please collect the following information to facilitate a quick resolution.

1. Product information, such as: serial number, software version, device installation

time, fault occurrence time, fault occurrence frequency, etc.

2. Device installation environment, such as: weather conditions, whether components are obstructed, have shadows, etc. Providing photos, videos, and other files of the recommended installation environment can assist in problem analysis.
3. Grid conditions.

9.5.2.1 System Failure

If the system experiences a problem not listed, or if following the instructions does not prevent the problem or abnormality, immediately stop operating the system and contact your dealer at once.

No.	Fault	Solution
1	Cannot search for the Smart Communication Stick's wireless signal	<ol style="list-style-type: none"> 1. Ensure no other device is connected to the Smart Communication Stick's wireless signal. 2. Ensure the App has been updated to the latest version. 3. Ensure the Smart Communication Stick is powered on normally, with the blue signal light flashing or solid on. 4. Ensure the smart device is within the communication range of the Smart Communication Stick. 5. Refresh the device list in the App. 6. Restart the inverter.
2	Cannot connect to the Smart Communication Stick's wireless signal	<ol style="list-style-type: none"> 1. Ensure no other device is connected to the Smart Communication Stick's wireless signal. 2. Restart the inverter or the Communication Stick, then try connecting to the Smart Communication Stick's wireless signal again. 3. Ensure Bluetooth encryption pairing is successful.
3	Cannot find the router SSID	<ol style="list-style-type: none"> 1. Place the router closer to the Smart Communication Stick, or add a WiFi repeater to enhance the WiFi signal. 2. Reduce the number of devices connected to the router.

No.	Fault	Solution
4	After all configuration is complete, the Smart Communication Stick fails to connect to the router	<ol style="list-style-type: none"> 1. Restart the inverter. 2. Check if the network name (SSID), encryption method, and password in the WiFi configuration are the same as those of the router. 3. Restart the router. 4. Place the router closer to the Smart Communication Stick, or add a WiFi repeater to enhance the WiFi signal.
5	After all configuration is complete, the Smart Communication Stick fails to connect to the server	Restart the router and the inverter.

9.5.2.2 Inverter Fault

9.5.2.2.1 Fault Handling (Fault Codes F01-F40)

Fault Code	Fault Name	Fault Cause	Troubleshooting Recommendation
F01	Grid Power Failure	<ol style="list-style-type: none"> 1. Grid power outage. 2. AC line or AC switch is disconnected. 	<ol style="list-style-type: none"> 1. The alarm will automatically clear after grid power is restored. 2. Check if the AC line or AC switch is disconnected.

Fault Code	Fault Name	Fault Cause	Troubleshooting Recommendation
F02	Grid Overvoltage Protection	Grid voltage is higher than the allowable range, or the high voltage duration exceeds the high voltage ride-through setting.	<ol style="list-style-type: none"> 1. If it occurs occasionally, it may be due to temporary grid abnormality. The inverter will resume normal operation after detecting a normal grid, requiring no manual intervention. 2. If it occurs frequently, check if the grid voltage is within the allowable range. If not, contact the local power operator. If it is, also modify the grid overvoltage protection point after obtaining consent from the local power operator. 3. If recovery is not possible for a long time, check if the AC-side circuit breaker and output cables are properly connected.

Fault Code	Fault Name	Fault Cause	Troubleshooting Recommendation
F03	Grid Undervoltage Protection	Grid voltage is lower than the allowable range, or the low voltage duration exceeds the low voltage ride-through setting.	<ol style="list-style-type: none"> 1. If it occurs occasionally, it may be due to temporary grid abnormality. The inverter will resume normal operation after detecting a normal grid, requiring no manual intervention. 2. If it occurs frequently, check if the grid voltage is within the allowable range. If not, contact the local power operator. If it is, also modify the grid undervoltage protection point after obtaining consent from the local power operator. 3. If recovery is not possible for a long time, check if the AC-side circuit breaker and output cables are properly connected.

Fault Code	Fault Name	Fault Cause	Troubleshooting Recommendation
F04	Grid Overvoltage Fast Protection	Abnormal grid voltage detection or ultra-high voltage triggering the fault.	<p>1. If it occurs occasionally, it may be due to temporary grid abnormality. The inverter will resume normal operation after detecting a normal grid, requiring no manual intervention.</p> <p>2. If it occurs frequently, check if the grid voltage is within the allowable range. If not, contact the local power operator. If it is, also modify the grid undervoltage protection point after obtaining consent from the local power operator.</p> <p>3. If recovery is not possible for a long time, check if the AC-side circuit breaker and output cables are properly connected.</p>
F05	10min Overvoltage Protection	The moving average of grid voltage within 10min exceeds the range specified by safety regulations.	Check if the grid voltage has been operating at a high level for an extended period. If it occurs frequently, check if the grid frequency is within the allowable range. If not, contact the local power operator. If it is, also modify the grid 10min overvoltage protection point after obtaining consent from the local power operator.

Fault Code	Fault Name	Fault Cause	Troubleshooting Recommendation
F06	Grid Overfrequency Protection	Grid abnormality: The actual grid frequency is higher than the local grid standard requirement.	<p>1. If it occurs occasionally, it may be due to temporary grid abnormality. The inverter will resume normal operation after detecting a normal grid, requiring no manual intervention.</p> <p>2. If it occurs frequently, check if the grid frequency is within the allowable range. If not, contact the local power operator. If it is, also modify the grid overfrequency protection point after obtaining consent from the local power operator.</p>
F07	Grid Underfrequency Protection	Grid abnormality: The actual grid frequency is lower than the local grid standard requirement.	<p>1. If it occurs occasionally, it may be due to temporary grid abnormality. The inverter will resume normal operation after detecting a normal grid, requiring no manual intervention.</p> <p>2. If it occurs frequently, check if the grid frequency is within the allowable range. If not, contact the local power operator. If it is, also modify the grid underfrequency protection point after obtaining consent from the local power operator.</p>

Fault Code	Fault Name	Fault Cause	Troubleshooting Recommendation
F08	Grid Frequency Shift Protection	Grid abnormality: The rate of change of the actual grid frequency does not comply with the local grid standard.	<p>1. If it occurs occasionally, it may be due to temporary grid abnormality. The inverter will resume normal operation after detecting a normal grid, requiring no manual intervention.</p> <p>2. If it occurs frequently, check if the grid frequency is within the allowable range. If not, contact the local power operator.</p>
F09	Anti-Islanding Protection	The grid has been disconnected, but grid voltage is maintained due to the presence of loads. Grid connection is stopped according to safety regulation protection requirements.	<p>1. If it occurs occasionally, it may be due to temporary grid abnormality. The inverter will resume normal operation after detecting a normal grid, requiring no manual intervention.</p> <p>2. If it occurs frequently, check if the grid frequency is within the allowable range. If not, contact the local power operator.</p>
F10	Voltage Ride-Through Undervoltage Fault	Grid abnormality: The duration of abnormal grid voltage exceeds the time specified for high/low voltage ride-through.	<p>1. If it occurs occasionally, it may be due to temporary grid abnormality. The inverter will resume normal operation after detecting a normal grid, requiring no manual intervention.</p> <p>2. If it occurs frequently, check if the grid voltage and frequency are within the allowable range and stable. If not, contact the local power operator.</p>

Fault Code	Fault Name	Fault Cause	Troubleshooting Recommendation
F11	Voltage Ride-Through Overvoltage Fault	Grid abnormality: The duration of abnormal grid voltage exceeds the time specified for high/low voltage ride-through.	<p>1. If it occurs occasionally, it may be due to temporary grid abnormality. The inverter will resume normal operation after detecting a normal grid, requiring no manual intervention.</p> <p>2. If it occurs frequently, check if the grid voltage and frequency are within the allowable range and stable. If not, contact the local power operator.</p>
F12	30mA Gfci Protection	The input-to-ground insulation impedance becomes low during inverter operation.	<p>1. If it occurs occasionally, it may be caused by temporary external line abnormality. Normal operation will resume after the fault is cleared, requiring no manual intervention.</p> <p>2. If it occurs frequently or recovery is not possible for a long time, check if the PV string's impedance to ground is too low.</p>
F13	60mA Gfci Protection	The input-to-ground insulation impedance becomes low during inverter operation.	<p>1. If it occurs occasionally, it may be caused by temporary external line abnormality. Normal operation will resume after the fault is cleared, requiring no manual intervention.</p> <p>2. If it occurs frequently or recovery is not possible for a long time, check if the PV string's impedance to ground is too low.</p>

Fault Code	Fault Name	Fault Cause	Troubleshooting Recommendation
F14	150mA Gfci Protection	The input-to-ground insulation impedance becomes low during inverter operation.	<p>1. If it occurs occasionally, it may be caused by temporary external line abnormality. Normal operation will resume after the fault is cleared, requiring no manual intervention.</p> <p>2. If it occurs frequently or recovery is not possible for a long time, check if the PV string's impedance to ground is too low.</p>
F15	Gfci Gradual Change Protection	The input-to-ground insulation impedance becomes low during inverter operation.	<p>1. If it occurs occasionally, it may be caused by temporary external line abnormality. Normal operation will resume after the fault is cleared, requiring no manual intervention.</p> <p>2. If it occurs frequently or recovery is not possible for a long time, check if the PV string's impedance to ground is too low.</p>
F16	DCI Level 1 Protection	The DC component of the inverter output current exceeds the allowable range specified by safety regulations or the machine's default settings.	<p>1. If the abnormality is caused by an external fault, the inverter will automatically resume normal operation after the fault disappears, requiring no manual intervention.</p> <p>2. If this alarm occurs frequently, affecting the normal power generation of the power station, please contact the dealer or after-sales service center.</p>

Fault Code	Fault Name	Fault Cause	Troubleshooting Recommendation
F17	DCI Level 2 Protection	The DC component of the inverter output current exceeds the allowable range specified by safety regulations or the machine's default settings.	<ol style="list-style-type: none"> 1. If the abnormality is caused by an external fault, the inverter will automatically resume normal operation after the fault disappears, requiring no manual intervention. 2. If this alarm occurs frequently, affecting the normal power generation of the power station, please contact the dealer or after-sales service center.

Fault Code	Fault Name	Fault Cause	Troubleshooting Recommendation
F18	Low Insulation Impedance	<ol style="list-style-type: none"> 1. PV string short circuit to protective earth. 2. PV string installed in a consistently damp environment with poor line-to-ground insulation. 3. Low insulation impedance between battery port lines and ground. 	<ol style="list-style-type: none"> 1. Check the impedance of the PV string/battery port to protective earth. A value greater than 80kΩ is normal. If the measured value is less than 80kΩ, please locate and rectify the short circuit point. 2. Check if the inverter's protective earth wire is correctly connected. 3. If it is confirmed that the impedance is indeed below the default value in rainy conditions, please reset the inverter's "Insulation Impedance Protection Point" via the App. <p>For inverters in the Australian and New Zealand markets, insulation impedance faults can also be alerted in the following ways:</p> <ol style="list-style-type: none"> 1. The inverter is equipped with a buzzer. When a fault occurs, the buzzer sounds continuously for 1 minute; if the fault persists, the buzzer sounds again every 30 minutes. 2. If the inverter is added to the monitoring platform and alarm notification methods are set, alarm information can be sent to customers via email.

Fault Code	Fault Name	Fault Cause	Troubleshooting Recommendation
F19	System Grounding Abnormality	1. The inverter's protective earth wire is not connected. 2. When the PV string output is grounded, no isolation transformer is connected on the inverter output side.	1. Please confirm whether the inverter's protective earth wire is properly connected. 2. In scenarios where the PV string output is grounded, please confirm whether an isolation transformer is connected on the inverter output side.
F20	Hard Anti-backflow Protection	Load abnormal fluctuation	1. If the abnormality is caused by an external fault, the inverter will automatically resume normal operation after the fault disappears, requiring no manual intervention. 2. If this alarm occurs frequently, affecting the normal power generation of the power station, please contact the dealer or after-sales service center.

Fault Code	Fault Name	Fault Cause	Troubleshooting Recommendation
F21	Internal Communication Link Break	Sub DSP1 communication timeout - Main DSP, Sub DSP2 Sub DSP2 communication timeout - Main DSP, Sub DSP2 Sub DSP1 communication timeout - Sub DSP1, Main DSP Main DSP communication timeout - Sub DSP1, Main DSP Sub DSP2 communication timeout - Sub DSP2, or Sub DSP1 Sub DSP2 communication timeout - Sub DSP2: 1. Chip not powered on 2. Chip firmware version error	Turn off the AC output side switch and the DC input side switch, wait for 5 minutes, then turn them back on. If the fault persists, please contact the dealer or after-sales service center.

Fault Code	Fault Name	Fault Cause	Troubleshooting Recommendation
		Main DSP CAN module error, Sub DSP1 CAN module error, or Sub DSP2 CAN module error: 1. Frame format error 2. Parity check error 3. CAN bus offline 4. Hardware CRC check error 5. Control bit set to receive (transmit) during transmission (reception) 6. Transmission to an unauthorized unit	
F22	Generator Waveform Detection Fault	1. This fault will be continuously displayed when no generator is connected. 2. When the generator is operating, failure to meet generator safety regulations will trigger this fault.	
F23	Generator Abnormal Connection		
F24	Generator Voltage Low		
F25	Generator Voltage High		
F26	Generator Frequency Low		

Fault Code	Fault Name	Fault Cause	Troubleshooting Recommendation
F27	Generator Frequency High		<p>1. Ignore this fault if no generator is connected.</p> <p>2. If this fault appears when the generator malfunctions, it is normal. After the generator recovers, wait for a period of time and the fault will clear automatically.</p> <p>3. This fault does not affect the normal operation in off-grid mode.</p> <p>4. When both the generator and the grid are connected and meet safety requirements, the grid has priority for grid connection, and the system will operate in grid-tied status.</p>
F28	Parallel System I/O Self-test Abnormality	Parallel communication cable not securely connected or parallel IO chip damaged	Check if the parallel communication cable is securely connected, then check if the IO chip is damaged. If so, replace the IO chip.
F29	Parallel System Grid Connection Reversed	Grid wires of some units are reversed with others	Reconnect the grid wires correctly.
F30	AC Sensor Self-Test Abnormality	Sampling abnormality exists in the AC sensor	Disconnect the AC output side switch and the DC input side switch, close them after 5 minutes. If the fault persists, please contact the distributor or after-sales service center.

Fault Code	Fault Name	Fault Cause	Troubleshooting Recommendation
F31	Leakage Current Sensor Self-Test Abnormality	Sampling abnormality exists in the leakage current sensor	Disconnect the AC output side switch and the DC input side switch, close them after 5 minutes. If the fault persists, please contact the distributor or after-sales service center.
F32	Inverter Internal Fault	A fault exists in the inverter	Disconnect the AC output side switch and the DC input side switch, close them after 5 minutes. If the fault persists, please contact the distributor or after-sales service center.
F33	Flash Read/Write Error	Possible causes: flash content changed; flash lifespan exhausted;	1. Upgrade to the latest program version 2. Contact the distributor or after-sales service center
F34	DC Arc Self-Test Fault	The arc detection module did not detect an arc fault during the self-test process	Disconnect the AC output side switch and the DC input side switch, close them after 5 minutes. If the fault persists, please contact the distributor or after-sales service center.

Fault Code	Fault Name	Fault Cause	Troubleshooting Recommendation
F35	Chamber Temperature Too High	Chamber temperature is too high. Possible causes: 1. Inverter installation location is not ventilated. 2. Ambient temperature is too high. 3. Internal fan operation is abnormal.	1. Check if the ventilation at the inverter installation location is adequate and if the ambient temperature exceeds the maximum allowable range. 2. If ventilation is poor or ambient temperature is too high, improve its ventilation and heat dissipation conditions. 3. If both ventilation and ambient temperature are normal, please contact the distributor or after-sales service center.

Fault Code	Fault Name	Fault Cause	Troubleshooting Recommendation
F36	Bus Overvoltage	BUS overvoltage. Possible causes: 1. PV voltage is too high; 2. Inverter BUS voltage sampling is abnormal; 3. Poor isolation effect of the dual-split transformer at the inverter's rear end, causing mutual interference when two inverters are grid-connected, with one inverter reporting DC overvoltage during grid connection;	Disconnect the AC output side switch and the DC input side switch, close them after 5 minutes. If the fault persists, please contact the distributor or after-sales service center.

Fault Code	Fault Name	Fault Cause	Troubleshooting Recommendation
F37	PV Input Overvoltage	PV input voltage is too high. Possible cause: Photovoltaic array configuration error: too many PV panels connected in series per string, causing the string's open-circuit voltage to exceed the inverter's maximum operating voltage	Check the series configuration of the corresponding PV array string to ensure the string's open-circuit voltage does not exceed the inverter's maximum operating voltage. After correcting the PV array configuration, the inverter alarm will disappear automatically.
F38	PV Continuous Hardware Overcurrent	1. Module configuration is unreasonable 2. Hardware damage	Disconnect the AC output side switch and the DC input side switch, close them after 5 minutes. If the fault persists, please contact the distributor or after-sales service center.
F39	PV Continuous Software Overcurrent	1. Module configuration is unreasonable 2. Hardware damage	Disconnect the AC output side switch and the DC input side switch, close them after 5 minutes. If the fault persists, please contact the distributor or after-sales service center.

Fault Code	Fault Name	Fault Cause	Troubleshooting Recommendation
F40, F98	String Reversal (String 1-n) n: Determined based on the actual number of inverter strings	PV String Reversal	Check if the strings are reversed.

9.5.2.2.2 Fault Handling (Fault Codes F41-F80)

Fault Code	Fault Name	Fault Cause	Troubleshooting Suggestions
F41	Generator Port Overload	<ol style="list-style-type: none"> 1. Off-grid side output exceeds the specifications. 2. Off-grid side short circuit. 3. Off-grid side voltage is too low. 4. When used as a large load port, the large load exceeds the specifications. 	Confirm the cause of the problem by checking data such as off-grid side output voltage, current, and power.

Fault Code	Fault Name	Fault Cause	Troubleshooting Suggestions
F42	DC Arc Fault (String 1-n) n: Determined by the actual number of inverter strings.	1. DC side connection terminals are loose. 2. DC side connection terminals have poor contact. 3. DC cable core is damaged, causing poor contact.	1. After the machine reconnects to the grid, check if the voltage and current of each string abnormally decrease or become zero. 2. Check if the DC side terminals are securely connected.
F43	Voltage Waveform Detection Abnormal	Grid anomaly: Abnormal grid voltage detection triggers the fault.	1. If it occurs occasionally, it may be due to a short-term grid anomaly. The inverter will resume normal operation after detecting a normal grid, requiring no manual intervention. 2. If it occurs frequently, please check if the grid voltage and frequency are within the allowable range and stable. If not, contact the local power utility.
F44	Grid Phase Loss Protection	Grid anomaly: There is a single-phase voltage dip in the grid.	1. If it occurs occasionally, it may be due to a short-term grid anomaly. The inverter will resume normal operation after detecting a normal grid, requiring no manual intervention. 2. If it occurs frequently, please check if the grid voltage and frequency are within the allowable range and stable. If not, contact the local power utility.

Fault Code	Fault Name	Fault Cause	Troubleshooting Suggestions
F45	Grid Voltage Imbalance	Excessive difference in grid phase voltages.	<p>1. If it occurs occasionally, it may be due to a short-term grid anomaly. The inverter will resume normal operation after detecting a normal grid, requiring no manual intervention.</p> <p>2. If it occurs frequently, please check if the grid voltage and frequency are within the allowable range and stable. If not, contact the local power utility.</p>
F46	Grid Phase Sequence Fault	Inverter and grid wiring anomaly: Wiring is not in positive sequence.	<p>1. Check if the inverter and grid wiring are in positive sequence. The fault will disappear automatically after correct wiring (e.g., swapping any two live wires).</p> <p>2. If the fault persists despite correct wiring, contact the dealer or after-sales service center.</p>
F47	Grid Power Loss Fast Protection	Quickly shuts down output after detecting a grid power loss condition.	The fault disappears automatically after grid power is restored.
F48	Grid Neutral Loss (Split Grid)	Neutral loss in a split-phase grid.	<p>1. The alarm disappears automatically after grid power is restored.</p> <p>2. Check if the AC wiring or AC switch is disconnected.</p>
F49	Live Wire to Ground Short Circuit	Output phase wire has low impedance or short circuit to PE.	Detect the impedance of the output phase wire to PE, locate the point with low impedance and repair it.

Fault Code	Fault Name	Fault Cause	Troubleshooting Suggestions
F50	DCV Level 1 Protection	Load abnormal fluctuation.	<p>1. If it is due to an anomaly introduced by an external fault, the inverter will automatically resume normal operation after the fault disappears, requiring no manual intervention.</p> <p>2. If this alarm occurs frequently, affecting normal power generation of the plant, contact the dealer or after-sales service center.</p>
F51	DCV Level 2 Protection	Load abnormal fluctuation.	
F52	Residual Current (GFCI) Multiple Fault Shutdown	North American safety regulations require no automatic recovery after multiple faults; manual recovery or waiting 24h is required.	Please check if the PV string's impedance to ground is too low.
F53	DC Arc Fault (AFCI) Multiple Fault Shutdown	North American safety regulations require no automatic recovery after multiple faults; manual recovery or waiting 24h is required.	<p>1. After the machine reconnects to the grid, check if the voltage and current of each string abnormally decrease or become zero.</p> <p>2. Check if the DC side terminals are securely connected.</p>

Fault Code	Fault Name	Fault Cause	Troubleshooting Suggestions
F54	External Communication Link Broken	Inverter external device communication lost, possibly due to peripheral power issue, communication protocol mismatch, or not configured for the corresponding peripheral.	Determine based on the actual model and detection enable bits; peripherals not supported by certain models will not be detected.
F55	Back-up Port Overload Fault	Prevents the inverter from continuously outputting overload.	Turn off some off-grid loads to reduce the inverter's off-grid output power.
F56	Back-up Port Overvoltage Fault	Prevents inverter output overvoltage from damaging loads.	<ol style="list-style-type: none"> 1. If it occurs occasionally, it may be caused by load switching and requires no manual intervention. 2. If it occurs frequently, contact the dealer or after-sales service center.
F57	External Box Fault	Wait time for Box relay switching is too long during grid-to-off-grid transition.	<ol style="list-style-type: none"> 1. Check if the Box is working normally. 2. Check if the Box communication wiring is correct.
F58	CT Loss Fault	CT connection wire disconnected (Japanese safety regulation requirement).	Check if the CT wiring is correct.

Fault Code	Fault Name	Fault Cause	Troubleshooting Suggestions
F59	Parallel CAN Communication Abnormal	Parallel communication cable not securely connected or some machines are offline.	Check if all machines are powered on and if the parallel communication cables are securely connected.
F60	Parallel Back-up Connection Reversed	Backup wires of some machines are reversed with others.	Reconnect the backup wires.
F61	Inverter Soft Start Failure	Inverter soft start failure during off-grid cold start.	Check if the inverter module is damaged.
F62	AC Sensor Fault	HCT sensor has an anomaly.	Disconnect the AC output side switch and DC input side switch, wait 5 minutes, then close the AC output side switch and DC input side switch. If the fault persists, contact the dealer or after-sales service center.
F63	Residual Current Sensor Fault	Residual current sensor has an anomaly.	Disconnect the AC output side switch and DC input side switch, wait 5 minutes, then close the AC output side switch and DC input side switch. If the fault persists, contact the dealer or after-sales service center.
F64	Inverter Internal Fault	Inverter has a fault.	Disconnect the AC output side switch and DC input side switch, wait 5 minutes, then close the AC output side switch and DC input side switch. If the fault persists, contact the dealer or after-sales service center.

Fault Code	Fault Name	Fault Cause	Troubleshooting Suggestions
F65	AC Terminal Temperature Too High	<p>AC terminal temperature is too high. Possible causes:</p> <ol style="list-style-type: none"> 1. Inverter installation location is not ventilated. 2. Ambient temperature is too high. 3. Internal fan operation is abnormal. 	<ol style="list-style-type: none"> 1. Check if the ventilation at the inverter installation location is good and if the ambient temperature exceeds the maximum allowable range. 2. If ventilation is poor or ambient temperature is too high, improve its ventilation and heat dissipation conditions. 3. If ventilation and ambient temperature are both normal, contact the dealer or after-sales service center.
F66	INV Module Temperature Too High	<p>Inverter module temperature is too high. Possible causes:</p> <ol style="list-style-type: none"> 1. Inverter installation location is not ventilated. 2. Ambient temperature is too high. 3. Internal fan operation is abnormal. 	<ol style="list-style-type: none"> 1. Check if the ventilation at the inverter installation location is good and if the ambient temperature exceeds the maximum allowable range. 2. If ventilation is poor or ambient temperature is too high, improve its ventilation and heat dissipation conditions. 3. If ventilation and ambient temperature are both normal, contact the dealer or after-sales service center.

Fault Code	Fault Name	Fault Cause	Troubleshooting Suggestions
F67	Boost Module Temperature Too High	Boost module temperature is too high. Possible causes: 1. Inverter installation location is not ventilated. 2. Ambient temperature is too high. 3. Internal fan operation is abnormal.	1. Check if the ventilation at the inverter installation location is good and if the ambient temperature exceeds the maximum allowable range. 2. If ventilation is poor or ambient temperature is too high, improve its ventilation and heat dissipation conditions. 3. If ventilation and ambient temperature are both normal, contact the dealer or after-sales service center.
F68	Output Filter Capacitor Over-temperature	Output filter capacitor temperature is too high. Possible causes: 1. Inverter installation location is not ventilated. 2. Ambient temperature is too high. 3. Internal fan operation is abnormal.	1. Check if the ventilation at the inverter installation location is good and if the ambient temperature exceeds the maximum allowable range. 2. If ventilation is poor or ambient temperature is too high, improve its ventilation and heat dissipation conditions. 3. If ventilation and ambient temperature are both normal, contact the dealer or after-sales service center.
F69	PV IGBT Short Circuit Fault	Possible causes: 1. IGBT short circuit. 2. Inverter sampling circuit abnormal.	Disconnect the AC output side switch and DC input side switch, wait 5 minutes, then close the AC output side switch and DC input side switch. If the fault persists, contact the dealer or after-sales service center.

Fault Code	Fault Name	Fault Cause	Troubleshooting Suggestions
F70	PV IGBT Open Circuit Fault	1. Software issue causing no PWM signal. 2. Drive circuit abnormal. 3. IGBT open circuit.	
F71	NTC Abnormal	NTC temperature sensor has an anomaly.	Disconnect the AC output side switch and DC input side switch, wait 5 minutes, then close the AC output side switch and DC input side switch. If the fault persists, contact the dealer or after-sales service center.
F72	PWM Signal Abnormal Fault	PWM abnormal waveform detected.	Disconnect the AC output side switch and DC input side switch, wait 5 minutes, then close the AC output side switch and DC input side switch. If the fault persists, contact the dealer or after-sales service center.
F73	CPU Interrupt Abnormal	CPU interrupt anomaly.	Disconnect the AC output side switch and DC input side switch, wait 5 minutes, then close the AC output side switch and DC input side switch. If the fault persists, contact the dealer or after-sales service center.
F74	Microelectronics Fault	Functional safety detection detected an anomaly.	Disconnect the AC output side switch and DC input side switch, wait 5 minutes, then close the AC output side switch and DC input side switch. If the fault persists, contact the dealer or after-sales service center.
F75	PV HCT Fault	Boost current sensor abnormal.	Disconnect the AC output side switch and DC input side switch, wait 5 minutes, then close the AC output side switch and DC input side switch. If the fault persists, contact the dealer or after-sales service center.

Fault Code	Fault Name	Fault Cause	Troubleshooting Suggestions
F76	1.5V Reference Abnormal	Reference circuit fault.	Disconnect the AC output side switch and DC input side switch, wait 5 minutes, then close the AC output side switch and DC input side switch. If the fault persists, contact the dealer or after-sales service center.
F77	0.3V Reference Abnormal	Reference circuit fault.	
F78	CPLD Version Identification Error	CPLD version identification error.	Disconnect the AC output side switch and DC input side switch, wait 5 minutes, then close the AC output side switch and DC input side switch. If the fault persists, contact the dealer or after-sales service center.
F79	CPLD Communication Fault	CPLD and DSP communication content error or timeout.	Disconnect the AC output side switch and DC input side switch, wait 5 minutes, then close the AC output side switch and DC input side switch. If the fault persists, contact the dealer or after-sales service center.
F80	Model Identification Fault	Fault regarding model identification error.	Disconnect the AC output side switch and DC input side switch, wait 5 minutes, then close the AC output side switch and DC input side switch. If the fault persists, contact the dealer or after-sales service center.

9.5.2.2.3 Fault Handling (Fault Codes F81-F121)

Fault Code	Fault Name	Fault Cause	Troubleshooting Recommendation
F81	Upper Bus Overvoltage	BUS overvoltage, possible causes: 1. PV voltage is too high; 2. Inverter BUS voltage sampling is abnormal; 3. Poor isolation effect of the dual-split transformer at the inverter's rear end, causing mutual interference when two inverters are grid-connected, with one inverter reporting DC overvoltage during grid connection;	Disconnect the AC output side switch and DC input side switch, wait for 5 minutes, then close the AC output side switch and DC input side switch. If the fault persists, please contact the dealer or after-sales service center.
F82	Lower Bus Overvoltage		
F83	Bus Overvoltage (Secondary CPU1)		Disconnect the AC output side switch and DC input side switch, wait for 5 minutes, then close the AC output side switch and DC input side switch. If the fault persists, please contact the dealer or after-sales service center.
F84	Upper Bus Overvoltage (Secondary CPU1)		

Fault Code	Fault Name	Fault Cause	Troubleshooting Recommendation
F85	Lower Bus Overvoltage (Secondary CPU1)	BUS overvoltage, possible causes: 1. PV voltage is too high; 2. Inverter BUS voltage sampling is abnormal; 3. Poor isolation effect of the dual-split transformer at the inverter's rear end, causing mutual interference when two inverters are grid-connected, with one inverter reporting DC overvoltage during grid connection;	
F86	Bus Overvoltage (Secondary CPU2)		Disconnect the AC output side switch and DC input side switch, wait for 5 minutes, then close the AC output side switch and DC input side switch. If the fault persists, please contact the dealer or after-sales service center.
F87	Upper Bus Overvoltage (Secondary CPU2)		

Fault Code	Fault Name	Fault Cause	Troubleshooting Recommendation
F88	Lower Bus Overvoltage (Secondary CPU2)	BUS overvoltage, possible causes: 1. PV voltage is too high; 2. Inverter BUS voltage sampling is abnormal; 3. Poor isolation effect of the dual-split transformer at the inverter's rear end, causing mutual interference when two inverters are grid-connected, with one inverter reporting DC overvoltage during grid connection;	
F89	Upper Bus Overvoltage (CPLD)		Disconnect the AC output side switch and DC input side switch, wait for 5 minutes, then close the AC output side switch and DC input side switch. If the fault persists, please contact the dealer or after-sales service center.

Fault Code	Fault Name	Fault Cause	Troubleshooting Recommendation
F90	Lower Bus Overvoltage (CPLD)	BUS overvoltage, possible causes: 1. PV voltage is too high; 2. Inverter BUS voltage sampling is abnormal; 3. Poor isolation effect of the dual-split transformer at the inverter's rear end, causing mutual interference when two inverters are grid-connected, with one inverter reporting DC overvoltage during grid connection;	
F91	Flying Capacitor Software Overvoltage	Flying capacitor overvoltage, possible causes: 1. PV voltage is too high;	Disconnect the AC output side switch and DC input side switch, wait for 5 minutes, then close the AC output side switch and DC input side switch. If the fault persists, please contact the dealer or after-sales service center.
F92	Flying Capacitor Hardware Overvoltage	2. Inverter flying capacitor voltage sampling is abnormal;	

Fault Code	Fault Name	Fault Cause	Troubleshooting Recommendation
F93	Flying Capacitor Undervoltage	Flying capacitor undervoltage, possible causes: 1. PV energy is insufficient; 2. Inverter flying capacitor voltage sampling is abnormal;	Disconnect the AC output side switch and DC input side switch, wait for 5 minutes, then close the AC output side switch and DC input side switch. If the fault persists, please contact the dealer or after-sales service center.
F94	Flying Capacitor Precharge Failure	Flying capacitor precharge failure, possible causes: 1. PV energy is insufficient; 2. Inverter flying capacitor voltage sampling is abnormal;	Disconnect the AC output side switch and DC input side switch, wait for 5 minutes, then close the AC output side switch and DC input side switch. If the fault persists, please contact the dealer or after-sales service center.
F95	Flying Capacitor Unable to Precharge	1. Control loop parameters are unreasonable. 2. Hardware damage.	Disconnect the AC output side switch and DC input side switch, wait for 5 minutes, then close the AC output side switch and DC input side switch. If the fault persists, please contact the dealer or after-sales service center.

Fault Code	Fault Name	Fault Cause	Troubleshooting Recommendation
F96, F97	String Overcurrent (String 1-n) n: Determined based on the actual number of inverter strings.	Possible causes: 1. String overcurrent; 2. String current sensor abnormal.	Disconnect the AC output side switch and DC input side switch, wait for 5 minutes, then close the AC output side switch and DC input side switch. If the fault persists, please contact the dealer or after-sales service center.
F99, F100	String Missing (String 1-n) n: Determined based on the actual number of inverter strings.	String fuse blown (if present).	Check if the fuse is blown.
F101	Battery 1 Precharge Fault	Battery 1 precharge circuit fault (precharge resistor burned out, etc.).	Check if the precharge circuit is in good condition. After powering on the battery only, check if the battery voltage and bus voltage are consistent. If not consistent, please contact the dealer or after-sales service center.
F102	Battery 1 Relay Fault	Battery 1 relay cannot operate normally.	After powering on the battery, check if the battery relay is working and if a closing sound is heard. If it does not operate, please contact the dealer or after-sales service center.

Fault Code	Fault Name	Fault Cause	Troubleshooting Recommendation
F103	Battery 1 Connection Overvoltage	Battery 1 connection voltage exceeds the machine's rated range.	Confirm if the battery voltage is within the machine's rated range.
F104	Battery 2 Precharge Fault	Battery 2 precharge circuit fault (precharge resistor burned out, etc.).	Check if the precharge circuit is in good condition. After powering on the battery only, check if the battery voltage and bus voltage are consistent. If not consistent, please contact the dealer or after-sales service center.
F105	Battery 2 Relay Fault	Battery 2 relay cannot operate normally.	After powering on the battery, check if the battery relay is working and if a closing sound is heard. If it does not operate, please contact the dealer or after-sales service center.
F106	Battery 2 Connection Overvoltage	Battery 2 connection voltage exceeds the machine's rated range.	Confirm if the battery voltage is within the machine's rated range.
F107	Grid Synchronization Timeout Fault During Grid Connection	Abnormal during carrier synchronization grid connection.	<ol style="list-style-type: none"> 1. Check if the synchronization line connection is normal. 2. Check if the master/slave settings are normal; 3. Disconnect the AC output side switch and DC input side switch, wait for 5 minutes, then close the AC output side switch and DC input side switch. If the fault persists, please contact the dealer or after-sales service center.

Fault Code	Fault Name	Fault Cause	Troubleshooting Recommendation
F108	DSP Communication Fault	-	-
F109	External STS Fault	Abnormal cable connection between inverter and STS.	Check if the wiring sequence of the harness between the inverter and the STS corresponds one-to-one in order.
F110	Reverse Power Flow Fault	<ol style="list-style-type: none"> 1. Inverter reports error and disconnects from grid. 2. meter communication is unstable. 3. Reverse power flow condition occurs. 	<ol style="list-style-type: none"> 1. Check if the inverter has other error messages. If yes, perform targeted troubleshooting; 2. Check if the meter connection is reliable; 3. If this alarm occurs frequently, affecting normal power generation of the power station, please contact the dealer or after-sales service center.
F111	Bypass Overload	-	-
F112	Black Start Fault	-	-
F113	Off-grid Output Instantaneous Overvoltage Fault	-	-

Fault Code	Fault Name	Fault Cause	Troubleshooting Recommendation
F114	Relay Fault 2	Relay abnormal, reasons: 1. Relay abnormal (relay short circuit). 2. Relay sampling circuit abnormal. 3. AC side wiring abnormal (possible loose connection or short circuit).	Disconnect the AC output side switch and DC input side switch, wait for 5 minutes, then close the AC output side switch and DC input side switch. If the fault persists, please contact the dealer or after-sales service center.
F115	SVG Precharge Failure	SVG precharge hardware failure.	Contact the dealer or after-sales service center.
F116	Nighttime SVG PID Prevention Fault	PID prevention hardware abnormal.	
F117	DSP Version Identification Error	DSP software version identification error.	Disconnect the AC output side switch and DC input side switch, wait for 5 minutes, then close the AC output side switch and DC input side switch. If the fault persists, please contact the dealer or after-sales service center.

Fault Code	Fault Name	Fault Cause	Troubleshooting Recommendation
F118	MOS Continuous Overvoltage	1. Software issue causing inverter drive to turn off earlier than flyback drive; 2. Inverter drive circuit abnormal causing inability to turn on; 3. PV voltage is too high; 4. Mos voltage sampling abnormal;	Disconnect the AC output side switch and DC input side switch, wait for 5 minutes, then close the AC output side switch and DC input side switch. If the fault persists, please contact the dealer or after-sales service center.
F119	Bus Short Circuit Fault	Hardware damage.	If the inverter remains off-grid after a BUS short circuit fault occurs, please contact the dealer or after-sales service center.
F120	Bus Sampling Abnormal	1. BUS voltage sampling hardware fault.	Disconnect the AC output side switch and DC input side switch, wait for 5 minutes, then close the AC output side switch and DC input side switch. If the fault persists, please contact the dealer or after-sales service center.
F121	DC Side Sampling Abnormal	1. BUS voltage sampling hardware fault. 2. Battery voltage sampling hardware fault. 3. Dcrlly relay fault.	Disconnect the AC output side switch and DC input side switch, wait for 5 minutes, then close the AC output side switch and DC input side switch. If the fault persists, please contact the dealer or after-sales service center.

Fault Code	Fault Name	Fault Cause	Troubleshooting Recommendation
F122	PV Connection Mode Setting Error	<p>There are three PV connection modes, taking four MPPT channels as an example:</p> <ol style="list-style-type: none"> 1. Parallel mode: i.e., AAAA mode (same-source mode), PV1-PV4 are from the same source, all 4 PV channels connect to the same solar panel. 2. Partial parallel mode: i.e., AACC mode, PV1 and PV2 are from the same source, PV3 and PV4 are from the same source. 3. Independent mode: i.e., ABCD mode (different-source), PV1, PV2, PV3, PV4 connect independently, each of the 4 PV channels connects to one solar panel. <p>If the actual PV connection mode does not match the</p>	<p>Check if the PV connection mode is set correctly (ABCD, AACC, AAAA). Reset the PV connection mode correctly.</p> <ol style="list-style-type: none"> 1. Confirm that each actual connected PV string is correctly connected; 2. If the PV strings are correctly connected, check via APP or screen whether the currently set "PV Connection Mode" corresponds to the actual connection mode; 3. If the currently set "PV Connection Mode" does not match the actual connection mode, use the APP or screen to set the "PV Connection Mode" to the mode consistent with the actual situation. After setting, disconnect PV and AC power and restart; 4. After setting, if the current "PV Connection Mode" matches the actual connection mode but this fault is still reported, please contact the dealer or after-sales service center.

Fault Code	Fault Name	Fault Cause	Troubleshooting Recommendation
		PV connection mode set in the device, this fault will be reported.	

9.5.2.2.4 Fault Handling (Fault Codes F122-F163)

Fault Code	Fault Name	Fault Cause	Troubleshooting Suggestions
F123	Multi-string PV Phase Error	PV Input Mode Setting Error	<p>Check if the PV connection mode is correctly set (ABCD, AACC, AAAA), and reset the PV connection mode correctly.</p> <ol style="list-style-type: none"> 1. Confirm that all actual connected PV strings are correctly wired; 2. If the PV is correctly connected, check via the APP or screen whether the currently set "PV Connection Mode" corresponds to the actual connection mode; 3. If the currently set "PV Connection Mode" does not match the actual connection mode, use the APP or screen to set the "PV Connection Mode" to the mode consistent with the actual situation. After setting, disconnect and restart the PV and AC power supply; 4. After completing the settings, if the current "PV Connection Mode" matches the actual connection mode but this fault still occurs, please contact the dealer or after-sales service center.
F124	Battery 1 Reverse Connection Fault	Battery 1 Positive and Negative Poles Reversed	Check if the battery and machine terminal polarities are consistent.

Fault Code	Fault Name	Fault Cause	Troubleshooting Suggestions
F125	Battery 2 Reverse Connection Fault	Battery 2 Positive and Negative Poles Reversed	Check if the battery and machine terminal polarities are consistent.
F126	Abnormal Battery Connection	Abnormal Battery Connection	Check if the battery is working properly.
F127	Battery Heatsink Over-temperature	Battery temperature is too high. Possible causes: 1. Inverter installation location is not ventilated. 2. Ambient temperature is too high. 3. Internal fan operation is abnormal.	Disconnect the AC output side switch and DC input side switch, wait for 5 minutes, then close the AC output side switch and DC input side switch. If the fault persists, please contact the dealer or after-sales service center.
F128	Reference Voltage Abnormal	Reference Circuit Fault	Disconnect the AC output side switch and DC input side switch, wait for 5 minutes, then close the AC output side switch and DC input side switch. If the fault persists, please contact the dealer or after-sales service center.
F129	Chassis Temperature Too Low	Chassis temperature is too low. Possible cause: Ambient temperature is too low.	Disconnect the AC output side switch and DC input side switch, wait for 5 minutes, then close the AC output side switch and DC input side switch. If the fault persists, please contact the dealer or after-sales service center.

Fault Code	Fault Name	Fault Cause	Troubleshooting Suggestions
F130	AC Side SPD Fault	AC Side Surge Protective Device Failure	Replace the AC side surge protective device.
F131	DC Side SPD Fault	DC Side Surge Protective Device Failure	Replace the DC side surge protective device.
F132	Internal Fan Abnormal	Internal fan abnormal. Possible causes: 1. Fan power supply abnormal; 2. Mechanical fault (stall); 3. Fan aged or damaged.	Disconnect the AC output side switch and DC input side switch, wait for 5 minutes, then close the AC output side switch and DC input side switch. If the fault persists, please contact the dealer or after-sales service center.
F133	External Fan Abnormal	External fan abnormal. Possible causes: 1. Fan power supply abnormal; 2. Mechanical fault (stall); 3. Fan aged or damaged.	
F134	PID Diagnosis Abnormal	PID hardware fault or PV voltage too high causing PID pause	PID pause warning caused by high PV voltage requires no action. PID hardware fault can be cleared by turning the PID switch off and then on. Replace the PID device.

Fault Code	Fault Name	Fault Cause	Troubleshooting Suggestions
F135	Circuit Breaker Trip Warning	Possible causes: Overcurrent or PV reverse connection caused the circuit breaker to trip;	Contact the dealer or after-sales service center; The cause of tripping is a PV short circuit or reverse connection. Check if there is a historical PV short circuit warning or historical PV reverse connection warning. If present, a technician needs to inspect the corresponding PV situation. After checking and confirming no fault, you can manually close the circuit breaker and clear this warning via the APP interface by clearing historical faults.
F136	Historical PV IGBT Short Circuit Warning	Possible causes: Overcurrent caused the circuit breaker to trip;	Contact the dealer or after-sales service center; Technicians need to check the Boost hardware and external string for faults according to the historical PV short circuit warning subcode. After checking and confirming no fault, this warning can be cleared via the APP interface by clearing historical faults.
F137 , F138	Historical PV Reverse Connection Warning (String 1-n) (n: determined by the actual number of inverter strings)	Possible causes: PV reverse connection caused the circuit breaker to trip;	Contact the dealer or after-sales service center; Technicians need to check the corresponding string for reverse connection according to the historical PV reverse connection warning subcode, and check if there is a voltage difference in the PV panel configuration. After checking and confirming no fault, this warning can be cleared via the APP interface by clearing historical faults.

Fault Code	Fault Name	Fault Cause	Troubleshooting Suggestions
F139	Flash Read/Write Error Warning	Possible causes: 1. Flash content changed; 2. Flash lifespan exhausted;	1. Upgrade to the latest firmware; 2. Contact the dealer or after-sales service center.
F140	Meter Communication Abnormal Alarm	This warning may only occur after anti-backflow function is enabled. Possible causes: 1. Meter not connected; 2. Communication cable connection between meter and inverter is incorrect.	Check the meter wiring, connect the meter correctly. If the fault persists after checking, please contact the dealer or after-sales service center.
F141	PV Panel Type Identification Failed	PV panel identification hardware abnormal	Contact the dealer or after-sales service center.
F142	String Mismatch	PV string mismatch, two strings under the same MPPT have different open-circuit voltage configurations	Check the open-circuit voltage of the two strings, configure strings with the same open-circuit voltage under the same MPPT. Long-term string mismatch poses safety risks.
F143	CT Not Connected	CT not connected	Check the CT wiring.
F144	CT Reverse Connection	CT reverse connection	Check the CT wiring.
F145	Ground Wire Missing Warning	Ground wire not connected	Check the ground wire.

Fault Code	Fault Name	Fault Cause	Troubleshooting Suggestions
F146	String Terminal High Temperature (String 1~8)	Register 37176 PV terminal temperature alarm subcode 1 is set	-
F147	String Terminal High Temperature (String 9~16)	Register 37177 PV terminal temperature alarm subcode 2 is set	-
F148	String Terminal High Temperature (String 17~20)	Register 37178 PV terminal temperature alarm subcode 3 is set	-
F149	Historical PV Reverse Connection Warning (String 33~48)	Possible causes: PV reverse connection caused the circuit breaker to trip;	Contact the dealer or after-sales service center; Technicians need to check the corresponding string for reverse connection according to the historical PV reverse connection warning subcode, and check if there is a voltage difference in the PV panel configuration. After checking and confirming no fault, this warning can be cleared via the APP interface by clearing historical faults.
F150	Battery 1 Low Voltage	Battery voltage below set value	-
F151	Battery 2 Low Voltage	Battery voltage below set value	-

Fault Code	Fault Name	Fault Cause	Troubleshooting Suggestions
F152	Battery Power Supply Low Voltage	Battery in non-charging mode, voltage below shutdown voltage	-
F153	Battery 1 High Voltage	-	-
F154	Battery 2 High Voltage	-	-
F155	Online Insulation Impedance Low	<p>1. PV string shorted to protective earth.</p> <p>2. PV string installed in a humid environment for a long time with poor line-to-ground insulation.</p>	<p>1. Check the impedance between the PV string and protective earth. If a short circuit is found, rectify the short circuit point.</p> <p>2. Check if the inverter's protective earth wire is correctly connected.</p> <p>3. If it is confirmed that the impedance is indeed below the default value in rainy conditions, please reset the "Insulation Impedance Protection Point".</p>
F156	Microgrid Overload Warning	backup terminal input current too high	Occasional occurrence requires no action; If this alarm occurs frequently, please contact the dealer or after-sales service center.
F157	Manual Reset	-	-
F158	Generator Phase Sequence Abnormal	-	-

Fault Code	Fault Name	Fault Cause	Troubleshooting Suggestions
F159	Multiplex Port Configuration Abnormal	Multiplex (Generator) port configured as microgrid or large load, but a generator is actually connected	Use the APP to change the multiplex (Generator) port configuration.
F160	EMS Forced Off-grid	EMS issued forced off-grid command, but off-grid function is not enabled	Enable the off-grid function.
F161	Passive Islanding Protection	-	-
F162	Grid Type Error	Actual grid type (two-phase or split-phase) does not match the set safety standard	Switch to the corresponding safety standard according to the actual grid type.
F163	Grid Phase Shift Protection	Grid abnormal: Grid voltage phase change rate does not comply with local grid standard.	<p>1. If it occurs occasionally, it may be a temporary grid anomaly. The inverter will resume normal operation after detecting a normal grid, requiring no manual intervention.</p> <p>2. If it occurs frequently, please check if the grid frequency is within the allowable range. If not, please contact the local power operator.</p>

9.5.2.2.5 Fault Phenomenon Handling

Fault Name	Fault Cause	Fault Handling Suggestions
Generator Fault	<ol style="list-style-type: none"> 1. This fault will be displayed continuously when the generator is not connected. 2. During generator operation, this fault will be triggered if generator safety regulations are not met. 	<ol style="list-style-type: none"> 1. Ignore this fault if the generator is not connected. 2. If this fault appears when the generator malfunctions, it is normal. Wait for a period after the generator recovers, and the fault will clear automatically. 3. This fault does not affect the normal operation of off-grid mode. 4. When both generator and grid are connected and meet safety requirements, grid priority is given for grid-tie, and the system will operate in grid-tie mode.
BMS Status Bit Error	BMS module fault	<p>Disconnect the AC output side switch and the DC input side switch. After 5 minutes, reconnect the AC output side switch and the DC input side switch. If the fault persists, please contact the dealer or after-sales service center.</p>
Ambient Temperature Too High	<ol style="list-style-type: none"> 1. Poor machine ventilation 2. Hot airflow recirculates to the ambient temperature sampling point 	<p>Disconnect the AC output side switch and the DC input side switch. After 5 minutes, reconnect the AC output side switch and the DC input side switch. If the fault persists, please contact the dealer or after-sales service center.</p>

Fault Name	Fault Cause	Fault Handling Suggestions
PV Terminal Temperature Too High	PV terminal temperature is too high. Possible causes: 1. Inverter installation location lacks ventilation. 2. Ambient temperature is too high. 3. Internal fan operation is abnormal.	1. Check if the ventilation at the inverter installation location is adequate and if the ambient temperature exceeds the maximum allowable range. 2. If ventilation is poor or ambient temperature is too high, please improve its ventilation and heat dissipation conditions. 3. If both ventilation and ambient temperature are normal, please contact the dealer or after-sales service center.
Bat Terminal Temperature Too High	Bat terminal temperature is too high. Possible causes: 1. Inverter installation location lacks ventilation. 2. Ambient temperature is too high.	1. Check if the ventilation at the inverter installation location is adequate and if the ambient temperature exceeds the maximum allowable range. 2. If ventilation is poor or ambient temperature is too high, please improve its ventilation and heat dissipation conditions. 3. If both ventilation and ambient temperature are normal, please contact the dealer or after-sales service center.

Fault Name	Fault Cause	Fault Handling Suggestions
AC Terminal Temperature High Warning	<p>AC terminal temperature is too high. Possible causes:</p> <ol style="list-style-type: none"> 1. Inverter installation location lacks ventilation. 2. Ambient temperature is too high. 3. Internal fan operation is abnormal. 	
Bat Terminal Temperature High Warning	<p>Bat terminal temperature is too high. Possible causes:</p> <ol style="list-style-type: none"> 1. Inverter installation location lacks ventilation. 2. Ambient temperature is too high. 	<ol style="list-style-type: none"> 1. Check if the ventilation at the inverter installation location is adequate and if the ambient temperature exceeds the maximum allowable range. 2. If ventilation is poor or ambient temperature is too high, please improve its ventilation and heat dissipation conditions. 3. If both ventilation and ambient temperature are normal, please contact the dealer or after-sales service center.
Group Three-Phase Grid Connection Wiring Fault	Group three-phase external wiring error	Re-wire the connections.

Fault Name	Fault Cause	Fault Handling Suggestions
Parallel Communication Timeout Shutdown	In parallel operation, if a slave unit fails to communicate with the master unit for more than 400 seconds.	Check if the parallel communication harness is securely connected. Check for duplicate slave addresses.
Three-Phase Off-Grid Phase Loss Fault	Phase loss in a three-phase system.	<ol style="list-style-type: none"> 1. Check if all inverters are powered on. 2. Check if each phase of the three-phase system is connected to an inverter.
Emergency Stop	External hardware emergency stop button triggered or remote emergency stop command triggered.	<ol style="list-style-type: none"> 1. If it was actively triggered by remote shutdown, it can be ignored. 2. If not actively triggered, please contact the dealer or after-sales service center.
One-Key Shutdown	Check via the App if the one-key shutdown function is enabled.	Disable the one-key shutdown.
Offline Shutdown	-	-
Remote Shutdown	-	-
Grid-Side Surge Protection Fault	-	-

Fault Name	Fault Cause	Fault Handling Suggestions
Off-Grid Side Surge Protection Fault	-	-
Sub-Node Communication Fault	Internal communication abnormality.	Restart the unit and observe if the fault is cleared.
Generator Communication Fault	Communication link abnormality between the control board and the generator.	<ol style="list-style-type: none"> 1. Check the communication harness link, observe if the fault is cleared. 2. Try restarting the unit, observe if the fault is cleared. 3. If the fault persists after restart, contact the after-sales service center.
Battery Overvoltage Protection	<ol style="list-style-type: none"> 1. Single cell voltage too high. 2. Voltage sampling line abnormality. 	Record the fault phenomenon, restart the battery, wait a few minutes, confirm if the fault disappears. If the problem persists after restart, please contact the after-sales service center.
	<ol style="list-style-type: none"> 1. Total battery voltage too high. 2. Voltage sampling line abnormality. 	
Battery Undervoltage Protection	<ol style="list-style-type: none"> 1. Single cell voltage too low. 2. Voltage sampling line abnormality. 	
	<ol style="list-style-type: none"> 1. Total battery voltage too low. 2. Voltage sampling line abnormality. 	

Fault Name	Fault Cause	Fault Handling Suggestions
Battery Overcurrent Protection	1. Charging current too high, battery current limiting abnormality: sudden changes in temperature and voltage values. 2. Inverter response abnormality.	
	Battery discharge current too high.	
Battery Overtemperature Protection	1. Ambient temperature too high. 2. Temperature sensor abnormality.	
	1. Ambient temperature too high. 2. Temperature sensor abnormality.	
Battery Low Temperature Protection	1. Ambient temperature too low. 2. Temperature sensor abnormality.	
	1. Ambient temperature too low. 2. Temperature sensor abnormality.	

Fault Name	Fault Cause	Fault Handling Suggestions
Battery Terminal Overtemperature Protection	Terminal temperature too high.	
Battery Imbalance Protection	<p>1. Excessive temperature difference. At different stages, the battery will limit battery power, i.e., limit charging/discharging current. Therefore, this issue is generally difficult to occur.</p> <p>2. Cell capacity degradation, leading to excessive internal resistance, large temperature rise during overcurrent, resulting in large temperature difference.</p> <p>3. Poor welding of cell tabs, causing the cell temperature to rise too quickly during overcurrent.</p> <p>4. Temperature sampling issue.</p> <p>5. Loose power line connection.</p>	

Fault Name	Fault Cause	Fault Handling Suggestions
	<ol style="list-style-type: none"> 1. Inconsistent cell aging levels. 2. Slave board chip issues can also cause excessive cell voltage difference. 3. Slave board balancing issues can also cause excessive cell voltage difference. 4. Caused by harness issues. 	
	<ol style="list-style-type: none"> 1. Inconsistent cell aging levels. 2. Slave board chip issues can also cause excessive cell voltage difference. 3. Slave board balancing issues can also cause excessive cell voltage difference. 4. Caused by harness issues. 	
Insulation Resistance Protection	Insulation resistance damaged.	Check if the ground wire is properly connected, restart the battery. If the problem persists after restart, please contact the after-sales service center.

Fault Name	Fault Cause	Fault Handling Suggestions
Precharge Failure Fault	Precharge failure.	Indicates that during the precharge process, the voltage across the precharge MOS always exceeds the specified threshold. Power off and restart, then observe if this fault persists. Check if the wiring is correct and if the precharge MOS is damaged.
Sampling Line Fault	Battery sampling line poor contact or disconnected.	Check wiring, restart the battery. If the problem persists after restart, please contact the after-sales service center.
	Cell voltage sampling line poor contact or disconnected.	
	Cell temperature sampling line poor contact or disconnected.	
	Dual-channel current comparison error too large, or current sampling line loop abnormality.	
	Dual-channel voltage comparison error too large or MCU vs AFE voltage comparison error too large, or voltage sampling line loop abnormality.	

Fault Name	Fault Cause	Fault Handling Suggestions
	Temperature sampling line loop abnormality or poor contact/disconnection.	
	Overvoltage level 5 or overtemperature level 5, tripped three-terminal fuse.	Tripped three-terminal fuse, need to contact after-sales service center to replace the main control board.
Relay or MOS Overtemperature	Relay or MOS overtemperature.	This fault indicates the MOSFET temperature exceeds the specified threshold. Power off and let it sit for 2 hours to allow temperature recovery.
Shunt Overtemperature	Shunt overtemperature.	This fault indicates the shunt temperature exceeds the specified threshold. Power off and let it sit for 2 hours to allow temperature recovery.
BMS1 Other Fault 1 (Residential Storage)	Relay or MOSFET open circuit.	<ol style="list-style-type: none"> 1. Upgrade software, power off and let it sit for 5 minutes, restart and see if the fault persists. 2. If it persists, replace the battery pack.
	Relay or MOSFET short circuit.	<ol style="list-style-type: none"> 1. Upgrade software, power off and let it sit for 5 minutes, restart and see if the fault persists. 2. If it persists, replace the battery pack.
	Communication abnormality between master cluster and slave cluster, or cell inconsistency between clusters.	<ol style="list-style-type: none"> 1. Check the slave unit's battery information and software version, and whether the communication line connection to the master unit is normal. 2. Upgrade software.

Fault Name	Fault Cause	Fault Handling Suggestions
	Battery system loop harness abnormality, causing the interlock signal not to form a loop.	Check if the termination resistor is installed correctly.
	BMS and PCS communication abnormality.	<ol style="list-style-type: none"> 1. Confirm if the communication line interface definition between the inverter and the connected battery is correct. 2. Please contact the after-sales service center, check backend data, observe if the inverter and battery software match correctly.
	BMS master controller and slave controller communication harness abnormality.	<ol style="list-style-type: none"> 1. Check wiring, restart the battery. 2. Upgrade battery firmware, if the problem persists after restart, please contact the after-sales service center.
	Communication loss between main negative chips.	
	Circuit breaker, shunt trip abnormality.	<ol style="list-style-type: none"> 1. Power off and let it sit for 5 minutes, restart and see if the fault persists. 2. Observe the PACK and PCU bottom blind-mate connectors, check if communication pins are loose or bent.
	MCU self-test failure.	Upgrade software, restart the battery. If the problem persists after restart, contact the after-sales service center.

Fault Name	Fault Cause	Fault Handling Suggestions
	1. Software version too low or BMS board damaged. 2. Large number of inverters in parallel, excessive inrush current during battery precharge.	1. Upgrade software, observe if the fault persists. 2. For parallel operation scenarios, perform a black start of the battery first, then start the inverters.
	MCU internal fault.	Upgrade software, restart the battery. Usually indicates detection of MCU or external component damage. If the problem persists after restart, please contact the after-sales service center.
	Total control current exceeds the specified threshold.	1. Power off and let it sit for 5 minutes, restart and see if the fault persists. 2. Check if the inverter power setting is too high, causing it to exceed the bus load.
	Inconsistent cells in parallel battery clusters.	Confirm if the cells in the parallel battery clusters are consistent.
	Parallel battery cluster positive/negative polarity reversed.	Check if the positive/negative polarity of the parallel battery clusters is reversed.
	Severe overtemperature/overvoltage etc. triggering the fire protection system.	Contact the after-sales service center.

Fault Name	Fault Cause	Fault Handling Suggestions
System Air Conditioning Faults	Air conditioning abnormality/failure.	Try restarting the system. If the fault is not resolved, please contact the after-sales service center.
	Cabinet door not closed.	Check if the cabinet door is properly closed.
	Supply voltage too high.	Confirm if the supply voltage value meets the air conditioner input voltage requirements. Confirm compliance before re-powering.
	Insufficient supply voltage.	
	No voltage input.	
	Unstable supply voltage.	
	Compressor voltage unstable.	Try restarting the system. If the fault is not resolved, please contact the after-sales service center.
	Sensor poor contact or damaged.	
	Air conditioner fan abnormality.	
BMS1 Other Fault 2 (Residential Storage)	DCDC internal voltage or current abnormality.	Refer to specific DC fault content.
	DCDC overload or heat sink temperature too high, etc.	
	Cell sampling abnormality or inconsistent aging levels.	Please contact the after-sales service center.

Fault Name	Fault Cause	Fault Handling Suggestions
	Fan action not executed normally.	Please contact the after-sales service center.
	Output terminal screws loose or poor contact.	<ol style="list-style-type: none"> 1. Power off the battery, check wiring and output terminal screw condition. 2. After confirmation, restart the battery, observe if the fault persists. If it persists, please contact the after-sales service center.
	Battery used for too long or cells severely damaged.	Please contact the after-sales service center to replace the pack.
	<ol style="list-style-type: none"> 1. Software version too low or BMS board damaged. 2. Large number of inverters in parallel, excessive inrush current during battery precharge. 	<ol style="list-style-type: none"> 1. Upgrade software, observe if the fault persists. 2. For parallel operation scenarios, perform a black start of the battery first, then start the inverters.
	Heating film damaged.	Please contact the after-sales service center.
	Heating film three-terminal fuse blown, heating function unavailable.	Please contact the after-sales service center.
	Software model, cell type, hardware model mismatch.	Check if the software model, SN number, cell type, and hardware model are consistent. If not, please contact the after-sales service center.
	Thermal management board communication line break.	<ol style="list-style-type: none"> 1. Power off and let it sit for 5 minutes, restart and see if the fault persists. 2. If the fault does not recover, contact after-sales to replace the pack.

Fault Name	Fault Cause	Fault Handling Suggestions
	Thermal management board communication line break.	<ol style="list-style-type: none"> 1. Power off and let it sit for 5 minutes, restart and see if the fault persists. 2. If the fault does not recover, contact after-sales to replace the pack.
	Thermal management board communication line break.	<ol style="list-style-type: none"> 1. Power off and let it sit for 5 minutes, restart and see if the fault persists. 2. If the fault does not recover, contact after-sales to replace the pack.
	Pack fan fault signal triggered.	<ol style="list-style-type: none"> 1. Power off and let it sit for 5 minutes, restart and see if the fault persists. 2. If the fault does not recover, contact after-sales to replace the pack.
DCDC Fault	Output port voltage too high.	Check the output port voltage. If the output port voltage is normal and the fault does not clear itself after restarting the battery, please contact the after-sales service center.
	DCDC module detects battery voltage exceeding maximum charging voltage.	Stop charging, discharge to below 90% SOC or let it sit for 2 hours. If ineffective and the fault persists after restart, please contact the after-sales service center.
	Heat sink temperature too high.	Let the battery sit for 1 hour to allow heat sink temperature to drop. If ineffective and the fault persists after restart, please contact the after-sales service center.
	Battery discharge current too high.	Check if the load exceeds the battery's discharge capability. Turn off the load or stop PCS operation for 60 seconds. If ineffective and the fault persists after restart, please contact the after-sales service center.

Fault Name	Fault Cause	Fault Handling Suggestions
	Output port power harness positive/negative polarity reversed with parallel clusters or PCS.	Turn off the battery manual switch, check if the output port wiring is correct, restart the battery.
	Output power relay cannot close.	Check if the output port wiring is correct and if there is a short circuit. If ineffective and the fault persists after restart, please contact the after-sales service center.
	Power device temperature too high.	Let the battery sit for 1 hour to allow internal power device temperature to drop. If ineffective and the fault persists after restart, please contact the after-sales service center.
	Relay welded/stuck.	If the fault persists after restart, please contact the after-sales service center.
Inter-Cluster Circulating Current Fault	1. Cell imbalance. 2. First power-on without full charge calibration.	Record the fault phenomenon, restart the battery, wait a few minutes, confirm if the fault disappears. If the problem persists after restart, please contact the after-sales service center.
BMS1 Other Fault 3 (Large-Scale Storage)	Communication abnormality with Linux module.	1. Check if the communication line connection is normal. 2. Upgrade software, restart the battery and observe if the fault persists. If it persists, please contact the after-sales service center.
	Cell temperature rise too fast.	Cell abnormality, contact after-sales to replace the pack.
	SOC below 10%.	Charge the battery.

Fault Name	Fault Cause	Fault Handling Suggestions
	SN writing does not comply with rules.	Check if the SN digit count is normal. If abnormal, please contact the after-sales service center.
	1. Daisy chain communication abnormality within a battery cluster. 2. Inconsistent cell aging levels between battery clusters.	1. Check the pack contact condition within a single battery cluster. 2. Confirm the usage status of each cluster, such as cumulative charge/discharge capacity, cycle count, etc. 3. Please contact the after-sales service center.
	Excessive humidity inside pack.	-
	Fuse blown.	Contact after-sales to replace the pack.
	Battery low charge.	Charge the battery.
BMS1 Other Fault 4 (Large-Scale Storage)	Circuit breaker abnormality.	Contact after-sales to replace the pack.
	External device abnormality.	Contact after-sales to replace the pack.
Contactactor Fault 1	-	-
Contactactor Fault 2	-	-
Overload Protection (Jinggui)	Sustained overload (exceeding 690KVA) for 10s.	Please contact the after-sales service center.
Overload Protection (Smart Port)	Sustained overload (exceeding 690KVA) for 10s.	Please contact the after-sales service center.

Fault Name	Fault Cause	Fault Handling Suggestions
Overcurrent Protection (Jinggui)	-	-
Overcurrent Protection (Smart Port)	-	-
Host AC Power On and Meter Communication Abnormality	<ol style="list-style-type: none"> 1. Possibly the meter is not connected to the host. 2. Possibly the meter communication line is loose. 	<ol style="list-style-type: none"> 1. Check if the meter is connected to the host. 2. Check if the meter communication line is loose.
Slave Unit with Meter Abnormality in Parallel System	Meter connected to a slave unit.	Set the machine with the meter as the host.
Slave AC Power On >10 Minutes Communication Timeout with Host Abnormality	<ol style="list-style-type: none"> 1. Slave address setting error. 2. Slave communication line loose. 	<ol style="list-style-type: none"> 1. Check if the slave address is duplicated. 2. Check if the parallel communication line is loose.

9.5.2.3 Battery Fault (LX A5.0-10)

 When the battery ALM indicator light shows red, combine with the SOC indicator light display status to locate and troubleshoot the fault.

No.	SOC Indicator	Fault Name	Resolution
1	○○○○●	Battery Overvoltage	Power off and let it sit for 2 hours. If the problem persists after restarting, contact the after-sales service center.
2	○○○●○	Battery Undervoltage	Please contact the after-sales service center.
3	○○○●●	High Cell Temperature	Power off and let it sit for 2 hours. If the problem persists after restarting, contact the after-sales service center.
4	○○●○○	Low Charging Temperature	Power off and wait for the temperature to recover. If the problem persists after restarting, contact the after-sales service center.
5	○○●●●	Low Discharge Temperature	Power off and wait for the temperature to recover. If the problem persists after restarting, contact the after-sales service center.
6	○○●●○	Charging Overcurrent	Restart the battery. If the problem persists after restarting, contact the after-sales service center.
7	○○●●●	Discharge Overcurrent	Restart the battery. If the problem persists after restarting, contact the after-sales service center.
8	○●○○○	Insulation Resistance Too Low	Please contact the after-sales service center.
9	○●○○●	Excessive Temperature Difference	Power off and let it sit for 2 hours. If the problem persists after restarting, contact the after-sales service center.
10	○●○●●	Excessive Cell Voltage Difference	Restart the battery and let it sit for 12 hours. If the problem persists, contact the after-sales service center.
11	○●●○○	Cell Inconsistency	Please contact the after-sales service center.
12	○●●○○	Wiring Harness Abnormal	Restart the battery. If the problem persists after restarting, contact the after-sales service center.

No.	SOC Indicator	Fault Name	Resolution
13	○●●●○	MOSFET Fails to Close	Restart the battery. If the problem persists after restarting, contact the after-sales service center.
14	○●●●●	MOSFET Fails to Close	Restart the battery. If the problem persists after restarting, contact the after-sales service center.
15	●○○○○	Parallel Cluster Fault	Please check if the battery models match. If they do not match, contact the after-sales service center.
16	●○○○●	Interlock Signal Fault	Check if the terminal resistor is installed correctly. If the problem persists after restarting, contact the after-sales service center.
17	●○○●○	BMU Communication Fault	Restart the battery. If the problem persists after restarting, contact the after-sales service center.
18	●○○●●	MCU Internal Communication Fault	Restart the battery. If the problem persists after restarting, contact the after-sales service center.
19	●○○○○	Circuit Breaker Sticking Fault	Please contact the after-sales service center.
20	●○●○○	Precharge Failure Fault	Restart the battery. If the problem persists after restarting, contact the after-sales service center.
21	●○●●○	MOSFET Overtemperature Fault	Power off and let it sit for 2 hours. If the problem persists after restarting, contact the after-sales service center.
22	●○●●●	Shunt Overtemperature Fault	Power off and let it sit for 2 hours. If the problem persists after restarting, contact the after-sales service center.
23	●●○○○	Reverse Connection Fault	Please contact the after-sales service center.
24	●●●●●	Microelectronics Fault	Please contact the after-sales service center.

9.5.2.4 Battery Fault (LX A5.0-30)

Alarm Status

● When the battery ALM indicator shows red, locate and troubleshoot the fault based on the status displayed by the SOC indicator.

No.	SOC Indicator	Fault Name	Resolution
1	○○○●	Battery Overvoltage Protection Battery Undervoltage Protection	<ol style="list-style-type: none"> 1. Check via the APP whether the inverter's charging current limit is 0. If it is 0, verify that the communication cable connection between the battery and the inverter is secure and communication is normal. 2. Power off and let it sit for 5 minutes. After restarting, confirm if the fault persists. 3. If the fault is not resolved, please contact the after-sales service center.
2	○○●●	Battery Overcurrent Protection	<ol style="list-style-type: none"> 1. Check via the APP if the battery model is correct. Confirm if the real-time battery current exceeds the charging current limit or discharge current limit. If it does, please contact the after-sales service center. 2. If it is lower, power off the battery or upgrade the firmware. Restart and confirm if the fault continues to occur. 3. If the fault is not resolved, please contact after-sales.

No.	SOC Indicator	Fault Name	Resolution
3	○ ○ ● ○	Battery Overtemperature Protection Battery Low Temperature Protection Battery Terminal Overtemperature Protection	Power off and let it sit for 60 minutes, waiting for the temperature to recover. If the problem persists after restarting, please contact the after-sales service center.
4	○ ● ○ ○	Battery Imbalance Protection SOH Too Low Fault	Power off and let it sit for 30 minutes. If the problem persists after restarting, please contact the after-sales service center.
5	● ○ ● ●	Pre-charge Failure Fault	1. Confirm if the battery output terminals and the inverter are connected reversely. 2. Power off and let it sit for 5 minutes. If the problem persists after restarting, please contact the after-sales service center.
6	○ ● ○ ●	Harness Fault	Confirm if the battery switch is closed. If the battery switch is closed and the problem persists, please contact the after-sales service center.
7	● ● ○ ○	Relay or MOS Overtemperature Shunt Overtemperature	Power off and let it sit for 30 minutes. If the problem persists after restarting, please contact the after-sales service center.

No.	SOC Indicator	Fault Name	Resolution
		Other BMS Faults: Output Port Overtemperature Fault	<ol style="list-style-type: none"> 1. Check if the battery power cables are tightened. 2. Power off and let it sit for 5 minutes. If the problem persists after restarting, please contact the after-sales service center.
8	○●●○	Other Protection: MOS Cannot Close	Power off and let it sit for 5 minutes. If the problem persists after restarting, please contact the after-sales service center.
9	○●●●	Other Protection: MOS Sticking	
10	●○○○	Other Protection: Parallel Cluster Fault	<ol style="list-style-type: none"> 1. Confirm if the type and installation position of the terminal resistor used are correct. 2. Confirm that the communication cable connections between batteries, and between the battery and inverter, are secure and communication is normal. 3. If the fault is not resolved, please contact the after-sales service center.
11	○○○○	Other Protection: Communication Loss with Inverter	<ol style="list-style-type: none"> 1. Confirm that the communication cable connections between batteries, and between the battery and inverter, are secure and communication is normal. 2. If the fault is not resolved, please contact the after-sales service center.

No.	SOC Indicator	Fault Name	Resolution
12	● ○ ○ ●	Other Protection: BMU Communication Fault	<ol style="list-style-type: none"> 1. Confirm if the type and installation position of the terminal resistor used are correct. 2. Confirm that the communication cable connections between batteries, and between the battery and inverter, are secure and communication is normal. 3. Power off and let it sit for 5 minutes. If the problem persists after restarting, please contact the after-sales service center.
13	● ○ ● ○	Other Protection: Breaker Sticking Fault	Power off and let it sit for 5 minutes. If the problem persists after restarting, please contact the after-sales service center.
14	● ● ○ ●	Other Protection: Software Fault	Restart the battery. If the problem persists after restarting, please contact the after-sales service center.
15	● ● ● ○	Other Protection: Hardware Overcurrent Fault	
16	● ● ● ●	Other Protection: Microelectronics Fault	
		Heating Film Three-Terminal Abnormality	<ol style="list-style-type: none"> 1. Upgrade the software. 2. Power off and let it sit for 5 minutes. If the problem persists after restarting, please contact the after-sales service center.

10 Technical Specifications

10.1 Inverter Parameters

Technical Data	GW3K-EO-G20	GW3.6K-EO-G20	GW5K-EO-G20	GW6K-EO-G20
Battery Side				
Battery Type	Li-Ion/Lead-acid			
Nominal Voltage (V)	48			
Voltage Range (V)	40-60			
Start-up Voltage (V)	44.2			
Number of Battery Inputs	1	1	1	1
Max. Continuous Charging Current (A)	70	90	120	130
Max. Continuous Discharging Current (A)	70	90	120	130
Max. Charging Power (kW)	3	3.6	5	6
Max. Discharging Power (kW)	3.3	4	5.5	6.6
PV Side				
Max. Input Power (kW)	6	7.2	10	12

Technical Data	GW3K-EO-G20	GW3.6K-EO-G20	GW5K-EO-G20	GW6K-EO-G20
Max. Input Voltage (V) ^{*1}	530	530	530	530
MPPT Operating Voltage Range (V) ^{*2}	50-480	50-480	50-480	50-480
MPPT Operating Voltage Range at Nominal Power (V)	180-480	220-480	150-480	180-480
Start-up Voltage (V)	60	60	60	60
Nominal Input Voltage (V)	360	360	360	360
Max. MPPT Current (A)	21	21	21/21	21/21
Max. MPPT Short Circuit Current (A)	26	26	26/26	26/26
Max. Backfeed Current to the Array (A)	0	0	0	0
Number of MPPTs	1	1	2	2
Number of Strings per MPPT	1	1	1	1
AC Side (On-Grid)				
Nominal Power (kW)	3	3.6	5	6
Max. Power (kW)	3.3	4	5.5	6.6

Technical Data	GW3K-EO-G20	GW3.6K-EO-G20	GW5K-EO-G20	GW6K-EO-G20
Nominal Power at 40°C (kW)	3	3.6	5	6
Max. Power at 40°C (kW)	3.3	4	5.5	6.6
Rated Apparent Power from Grid (kVA)	3	3.6	5	6
Max. Apparent Power from Grid (kVA)	8.0	8.0	8.0	8.0
Nominal Voltage (V)	220/230, L/N/PE	220/230, L/N/PE	220/230, L/N/PE	220/230, L/N/PE
Voltage Range (V)	170~280	170~280	170~280	170~280
Nominal Frequency (Hz)	50/60	50/60	50/60	50/60
Frequency Range (Hz)	45~55/55~65	45~55/55~65	45~55/55~65	45~55/55~65
Rated Current from Grid (A)	13.7 @220V 13.1 @230V	16.4 @220V 15.7 @230V	22.8 @220V 21.8 @230V	27.3 @220V 26.1 @230V
Max. Current from Grid (A)	35	35	35	35
Max. Output Fault Current (Peak and Duration) (A)	96A, 3μs	96A, 3μs	96A, 3μs	96A, 3μs
Inrush Current (Peak and Duration) (A)	96A, 3μs	96A, 3μs	96A, 3μs	96A, 3μs

Technical Data	GW3K-EO-G20	GW3.6K-EO-G20	GW5K-EO-G20	GW6K-EO-G20
Power Factor	0.8 leading~0.8 lagging	0.8 leading~0.8 lagging	0.8 leading~0.8 lagging	0.8 leading~0.8 lagging
THDi	<3%	<3%	<3%	<3%
Maximum Output Overcurrent Protection (A)	53	53	88	88
Type of Voltage	a.c.	a.c.	a.c.	a.c.
AC Side (Back-up Port)				
Rated Apparent Power (kVA)	3	3.6	5	6
Max. Apparent Power (kVA)	Off-grid: 3.3 (7.2, 10s) On-grid: 8	Off-grid: 4 (7.2, 10s) On-grid: 8	Off-grid: 5.5 (12, 10s) On-grid: 8	Off-grid: 6.6 (12, 10s) On-grid: 8
Nominal Voltage (V)	220/230, L/N /PE	220/230, L/N/P E	220/230, L/N /PE	220/230, L/N /PE
Nominal Frequency (Hz)	50/60	50/60	50/60	50/60
Frequency Range (Hz)	45~55/55~65	45~55/55~65	45~55/55~65	45~55/55~65
Rated Current (A)	13.7 @220V 13.1 @230V	16.4 @220V 15.7 @230V	22.8 @220V 21.8 @230V	27.3 @220V 26.1 @230V
Max. Current (A)*3	Off-grid: 15 On-grid: 35	Off-grid: 18 On-grid: 35	Off-grid: 25 On-grid: 35	Off-grid: 30 On-grid: 35

Technical Data	GW3K-EO-G20	GW3.6K-EO-G20	GW5K-EO-G20	GW6K-EO-G20
Max. Fault Current (Peak and Duration) (A)	96A, 3μs	96A, 3μs	96A, 3μs	96A, 3μs
Inrush Current (Peak and Duration) (A)	96A, 3μs	96A, 3μs	96A, 3μs	96A, 3μs
Maximum Overcurrent Protection (A)	53	53	88	88
THDv (@Linear Load)	<3%	<3%	<3%	<3%
On/Off-grid Switching Time (ms)	≤4	≤4	≤4	≤4
AC Side (Smart Port)				
Rated Apparent Power (kVA)	3	3.6	5	6
Max. Apparent Power (kVA)	8	8	8	8
Nominal Voltage (V)	220/230	220/230	220/230	220/230
Voltage Range (V)	170~280	170~280	170~280	170~280
Nominal Frequency (Hz)	50/60	50/60	50/60	50/60
Frequency Range (Hz)	45~55/55~65	45~55/55~65	45~55/55~65	45~55/55~65
Max. Current (A)	35	35	35	35
Efficiency				

Technical Data	GW3K-EO-G20	GW3.6K-EO-G20	GW5K-EO-G20	GW6K-EO-G20
Max. Efficiency	98.6%			
Max. Battery to AC Efficiency	96.0%			
MPPT Efficiency	99.9%			
Protection				
PV String Current Monitoring	Integrated	Integrated	Integrated	Integrated
PV Insulation Resistance Detection	Integrated	Integrated	Integrated	Integrated
Residual Current Monitoring	Integrated	Integrated	Integrated	Integrated
PV Reverse Polarity Protection	Integrated	Integrated	Integrated	Integrated
Anti-islanding Protection	Integrated	Integrated	Integrated	Integrated
AC Overcurrent Protection	Integrated	Integrated	Integrated	Integrated
AC Short Circuit Protection	Integrated	Integrated	Integrated	Integrated
AC Overvoltage Protection	Integrated	Integrated	Integrated	Integrated
DC Surge Protection	Type III	Type III	Type III	Type III
AC Surge Protection	Type II	Type II	Type II	Type II

Technical Data	GW3K-EO-G20	GW3.6K-EO-G20	GW5K-EO-G20	GW6K-EO-G20
General Data				
Operating Temperature Range (°C)	-35~+60	-35~+60	-35~+60	-35~+60
Operating Environment	Indoor/Outdoor	Indoor/Outdoor	Indoor/Outdoor	Indoor/Outdoor
Storage Temperature (°C)	-40~+85	-40~+85	-40~+85	-40~+85
Relative Humidity	0~95%	0~95%	0~95%	0~95%
Max. Operating Altitude (m)	3000	3000	3000	3000
Cooling Method	Smart Fan Cooling	Smart Fan Cooling	Smart Fan Cooling	Smart Fan Cooling
User Interface	LCD,WLAN+APP	LCD, WLAN+APP	LCD, WLAN+APP	LCD,WLAN+APP
Communication with BMS	CAN	CAN	CAN	CAN
Communication	RS485, WiFi+bluetooth	RS485, WiFi+bluetooth	RS485, WiFi+bluetooth	RS485, WiFi+bluetooth
Communication Protocols	Modbus-RTU	Modbus-RTU	Modbus-RTU	Modbus-RTU
Weight (kg)	< 13	< 13	< 13	< 13
Dimension (W×H×D mm)	337*456*201	337*456*201	337*456*201	337*456*201
Noise Emission (dB)	< 35	< 35	< 55	< 55

Technical Data	GW3K-EO-G20	GW3.6K-EO-G20	GW5K-EO-G20	GW6K-EO-G20
Topology	Non-isolated	Non-isolated	Non-isolated	Non-isolated
Power Self-consumption at Night (W)	<20	<20	<20	<20
Ingress Protection Rating	IP66	IP66	IP66	IP66
Anti-corrosion Class	C4L	C4L	C4L	C4L
DC Connector	PV: JK01M ((4~6 mm ²) BAT: OT (Max.35mm ²)	PV: JK01M ((4~6 mm ²) BAT: OT (Max.35mm ²)	PV: JK01M ((4~6 mm ²) BAT: OT (Max.35mm ²)	PV: JK01M ((4~6 mm ²) BAT: OT (Max.35mm ²)
AC Connector	OT (Max.6m m ²)	OT (Max.6mm ²)	OT (Max.6mm ²)	OT (Max.6m m ²)
Environmental Category	4K4H	4K4H	4K4H	4K4H
Pollution Degree	III	III	III	III
Overvoltage Category	DC II/ AC III	DC II/ AC III	DC II/ AC III	DC II/ AC III
Protective Class	I	I	I	I
Decisive Voltage Classification (DVC)	Battery: A PV: C AC: C Com: A	Battery: A PV: C AC: C Com: A	Battery: A PV: C AC: C Com: A	Battery: A PV: C AC: C Com: A
Mounting Method	Wall Mounted	Wall Mounted	Wall Mounted	Wall Mounted

Technical Data	GW3K-EO-G20	GW3.6K-EO-G20	GW5K-EO-G20	GW6K-EO-G20
Active Anti-islanding Method	SMS (Slip-mode frequency) +AFD ^{*3}	SMS (Slip-mode frequency) +AFD ^{*3}	SMS (Slip-mode frequency) +AFD ^{*3}	SMS (Slip-mode frequency) +AFD ^{*3}
Type of Electrical Supply System	TN-S, TN-C, TN-C-S, TT	TN-S, TN-C, TN-C-S, TT	TN-S, TN-C, TN-C-S, TT	TN-S, TN-C, TN-C-S, TT
Country of Manufacture	China	China	China	China
Certification				
Grid Standard	PC3、RETIE、IS166221、IS17980			
Safety Regulation	IEC62109			
EMC	EN IEC 61000-6 Series、IEC62920			

*1: When the input voltage is greater than 500V, the inverter will enter standby mode, and when the voltage returns to below 490V the inverter will return to normal operation.

*2: Please refer to the user manual for the MPPT Voltage Range at Nominal Power.

*3: AFDPF: Active Frequency Drift with Positive Feedback

10.2 Battery Technical Specifications

10.2.1 LX A5.0-10

Technical Data	LX A5.0-10	2*LX A5.0-10	n*LX A5.0-10
Usable Energy (kWh) *1	5	10	n×5
Battery Module	LX A5.0-10: 51.2V 5.0kWh		
Number of Modules	1	2	n

Technical Data	LX A5.0-10	2*LX A5.0-10	n*LX A5.0-10
Cell Type	LFP (LiFePO ₄)		
Nominal Voltage (V)	51.2		
Operating Voltage Range (V)	47.5~57.6		
Nominal Dis-/Charge Current (A) *2	60	120	n×60 *3
Nominal Power (kW) *2	3	6	n×3 *3
Operating Temperature Range (°C)	Charge: 0~+50; Discharge: -10~+50		
Relative Humidity	0~95%		
Max. Operating Altitude (m)	3000		
Communication	CAN		
Weight (kg)	40	80	n×40
Dimensions (W×H×D mm)	LX A5.0-10 Module: 442×133×420 (Excluding hanger); 483x133x452 (Include hanger)		
Ingress Protection Rating	IP21		
Storage Temperature (°C)	0~+40 (< One Year); -20~0 (≤One Month); +40~+45(≤One Month)		
Mounting Method	Cabinet / Floor stacked / Wall-Mounted		
Round-trip Efficiency *4	95%		
Cycle Life *5	≥5000		

Technical Data		LX A5.0-10	2*LX A5.0-10	n*LX A5.0-10
Standard and Certification	Safety	IEC62619、IEC63056、IEC62040-1、INmetro		
	EMC	EN IEC61000-6-1, EN IEC61000-6-2, EN IEC61000-6-3, EN IEC61000-6-4		
	Transportation	UN38.3、ADR		

*1: Test conditions: 100% DOD, 0.2C charge & discharge at +25±2°C for battery system at beginning of life. System Usable Energy may vary with different Inverters.

*2: Nominal Discharge/Charge Current and power derating will occur related to Temperature and State of Charge (SOC).

*3: Based on using a Battery Combiner Box to parallelize battery modules.

*4: Based on a 2.5~3.65V voltage range @25±2°C of the Cell under 0.2C/0.2C Cell test condition. Cell 0.6C/0.6C Round-trip Efficiency is approximately 94%~95%.

*5: Based on a 2.87~3.59V voltage range @25±2°C of the Cell under 0.6C/0.6C test condition and 70% End of Life (EOL).

n: Maximum 15.

10.2.2 LX A5.0-30

Technical Parameters	LX A5.0-30
Nominal Capacity (kWh)	5.12
Usable energy (kWh) * 1	5
Cell Type	LFP (LiFePO4)
Operating Voltage Range (V)	43.2~58.24
Rated Capacity (Ah)	100
Nominal Charge Current (A) *2	60

Technical Parameters	LX A5.0-30
Max. Continuous Charge Current (A) *2*3	90
Nominal Discharge Current (A) *2	100
Max. Continuous Discharge Current (A) *2*3	150
Max. Pulse Discharge Current (A)*2*3	<200A (30s)
Max. Continuous Discharge Power (W)	7200
Communication	CAN
Operating Temperature Range (°C)	Charge: $0 < T \leq 55$ Discharge: $-20 < T \leq 55$
Maximum Operating Altitude (m)	4000
Weight (Kg)	44
Dimensions (W x H x D mm)	442*133*520 (Excluding hanger) 483*133*559 (Including hanger)
Ingress Protection Rating	IP20
Application Method	On-grid/On-grid + Backup/ off Grid
Scalability	Max. 30 in Parallel (150kWh) (Hand to hand /Combiner box /Busbar)
Mounting Method	19-inch standard rack, Floor-mounted, Wall-Mounted
Round-trip Efficiency*1	$\geq 96\%$
Safety	IEC62619、IEC63056、N140

Technical Parameters	LX A5.0-30
EMC	EN IEC61000-6-1、EN IEC61000-6-2、EN IEC61000-6-3、EN IEC61000-6-4
Transportation	UN38.3、ADR
Environment	ROHS

*1 Test conditions: 100% DOD, 0.2C charge & discharge at 25°C± 2°C, at the beginning of life.

*2 The system's working current and power values will be related to temperature and State of Charge (SOC)

*3 Max charge / discharge current and power values maybe variant with different inverter models.

10.3 Smart Meter Technical Parameters

10.3.1 GMK110

Technical Parameters		GMK110	
	Application	Single-phase	
Input Parameters	Voltage	Rated Voltage (V)	220
		Voltage Range (V)	85~288
		Rated Voltage Frequency (Hz)	50/60
	Current	CT Ratio	120A/40mA
		Number of CTs	1
Communication		RS485	
Communication Distance (m)		1000	
Human-Machine Interface		2LED	
Accuracy	Voltage/Current	Class I	
	Active Energy	Class I	
	Reactive Energy	Class II	
Power Consumption (W)		< 5	
Dimensions (W x H x D mm)		19*85*67	

Technical Parameters		GMK110
Mechanical Parameters	Weight (g)	50
	Installation Method	DIN Rail Mounting
Environmental Parameters	IP Rating	IP20
	Operating Temperature Range (°C)	-30 ~ 60
	Storage Temperature Range (°C)	-30 ~ 60
	Relative Humidity (non-condensing)	0~95%
	Maximum Operating Altitude (m)	3000

11 Appendix

11.1 FAQ

11.1.1 How to Perform Meter/CT Assisted Test?

The meter test function can detect whether the meter CT is connected correctly and the current operating status of the meter and CT.

- Method One:

1. Go to **[Home]** > **[Settings]** > **[Meter/CT Assisted Test]** to enter the test page.
2. Click Start Test, wait for the test to complete, and then view the test results.

- Method Two:

1. Click  > **[System Setup]** > **[Quick Setting]** > **[Meter/CT Assisted Test]** to enter the test page.
2. Click Start Test, wait for the test to complete, and then view the test results.

11.1.2 How to Upgrade Device Version

Through firmware information, you can view or upgrade the inverter's DSP version, ARM version, BMS version, and communication module software version. Some communication modules do not support upgrading the software version via the App. Please refer to the actual situation.

- **Prompt Upgrade:**

When the user opens the APP, an upgrade prompt pops up on the homepage. The user can choose whether to upgrade. If upgrade is selected, follow the on-screen instructions to complete the upgrade.

- **Regular Upgrade:**

Go to **[Homepage]** > **[Settings]** > **[Firmware Information]** to enter the firmware information viewing interface.

Click "Check for Updates". If a new version is available, follow the on-screen

instructions to complete the upgrade.

- **Forced Upgrade:**

The APP pushes upgrade information. The user must upgrade as prompted; otherwise, the APP cannot be used. Follow the on-screen instructions to complete the upgrade.

11.2 Terminology Explanation

- **Overvoltage Category Definition**

- **Overvoltage Category I:** Equipment connected to circuits with measures to limit transient overvoltages to a relatively low level.
- **Overvoltage Category II:** Energy-consuming equipment supplied from fixed electrical installations. This category includes appliances, portable tools, and other household and similar loads. If special requirements for the reliability and suitability of such equipment exist, Overvoltage Category III is applied.
- **Overvoltage Category III:** Equipment in fixed electrical installations where reliability and suitability must meet special requirements. This includes switchgear in fixed installations and industrial equipment permanently connected to fixed electrical installations.
- **Overvoltage Category IV:** Equipment used at the origin of the electrical installation, such as electricity meters and primary overcurrent protection devices.

- **Damp Location Category Definition**

Environmental Parameters	Levels		
	3K3	4K2	4K4H
Temperature Range	0~+40°C	-33~+40°C	-33~+40°C
Humidity Range	5% to 85%	15% to 100%	4% to 100%

- **Environment Category Definition:**

- **Outdoor Inverter:** Ambient air temperature range of -25°C to +60°C, suitable for Pollution Degree 3 environment.
- **Indoor Type II Inverter:** Ambient air temperature range of -25°C to +40°C, suitable for Pollution Degree 3 environment.
- **Indoor Type I Inverter:** Ambient air temperature range of 0°C to +40°C, suitable

for Pollution Degree 2 environment.

• **Pollution Degree Category Definition**

- **Pollution Degree 1:** No pollution or only dry, non-conductive pollution.
- **Pollution Degree 2:** Normally only non-conductive pollution occurs. Temporary conductivity caused by condensation must be considered.
- **Pollution Degree 3:** Conductive pollution occurs, or dry non-conductive pollution becomes conductive due to condensation.
- **Pollution Degree 4:** Persistent conductive pollution occurs, for example due to conductive dust, rain, or snow.

11.3 Battery SN Code Meaning

*****2388*****
 └─┘

The 11th-14th digits

LXD10DSC0002

Digits 11-14 of the product SN code represent the production time code.

The production date in the image above is 2023-08-08.

- Digits 11 and 12 represent the last two digits of the production year, e.g., 2023 is represented as 23;
- Digit 13 represents the production month, e.g., August is represented as 8;
Details are as follows:

Month	Jan-Sep	October	November	December
Month Code	1~9	A	B	C

- Digit 14 represents the production day, e.g., the 8th is represented as 8;
Numbers are used preferentially, e.g., 1~9 represent the 1st~9th day, A represents the 10th day, and so on. The letters I and O are not used to avoid confusion. Details are as follows:

Production Date	1	2	3	4	5	6	7	8	9
-----------------	---	---	---	---	---	---	---	---	---

Code	1	2	3	4	5	6	7	8	9
------	---	---	---	---	---	---	---	---	---

Production Date	10th	11th	12th	13th	14th	15th	16t h	17t h	18t h	19t h	20t h
Code	A	B	C	D	E	F	G	H	J	K	L

Production Date	21st	22nd	23rd	24th	25th	26t h	27t h	28t h	29t h	30t h	31st
Code	M	N	P	Q	R	S	T	U	V	W	X

12 Contact Information

GoodWe Technologies Co., Ltd.
No. 90 Zijin Road, High-tech Zone, Suzhou, China
400-998-1212
www.goodwe.com
service@goodwe.com